



GILLETTE GENERATORS

LIQUID COOLED NAT. GAS ENGINE GENERATOR SET

60 HZ MODEL
SP-2650

Model	STANDBY 120°C RISE		
	HZ	LPG	N.G.
SP-2650-60 HERTZ	60	170	265



All generator sets are USA prototype built and thoroughly tested. Production models are USA factory built and 100% load tested.



UL2200, UL1446, UL508, UL142, UL498



NFPA 110, 99, 70, 37

All generator sets meet NFPA-110 Level 1, when equipped with the necessary accessories and installed per NFPA standards.



NEC 700, 701, 702, 708



NEMA ICS10, MG1, ICS6, AB1



ANSI C62.41, 27, 59, 32, 480, 40Q, 81U, 360-05



ASCE 7-05 & 7-10

All generator sets meet 180 MPH rating.



EPA 40CFR Part 60, 1048, 1054, 1065, 1068

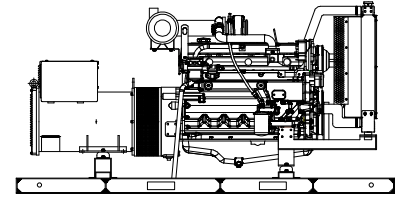

“OPEN” GEN-SET

There is no enclosure, so gen-set must be placed within a weather protected area, un-inhabited by humans or animals, with proper ventilation. Silencer not supplied, as installation requirements are not known. However, this item is available as optional equipment.

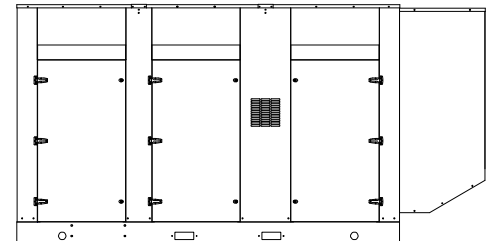

“LEVEL 2” HOUSED GEN-SET

Full aluminum weather protection and superior sound attenuation for specific low noise applications. Critical grade muffler is standard

GENERATOR RATINGS

GENERATOR MODEL	VOLTAGE		PH	HZ	LIQUID PROPANE GAS FUEL		NATURAL GAS FUEL	
	L-N	L-L			120°C RISE STANDBY RATING		120°C RISE STANDBY RATING	
					KW/KVA	AMP	KW/KVA	AMP
SP-2650-3-2	120	208	3	60	170/212	590	265/331	921
SP-2650-3-3	120	240	3	60	170/212	512	265/331	798
SP-2650-3-4	277	480	3	60	170/212	256	265/331	399
SP-2650-3-5	127	220	3	60	170/212	558	265/331	870
SP-2650-3-16	346	600	3	60	170/212	205	265/331	319

RATINGS: All three phase gen-sets are 12 lead windings, rated at .8 power factor. 120°C “STANDBY RATINGS” are strictly for gen-sets that are used for back-up emergency power to a failed normal utility power source. This standby rating allows varying loads, with no overload capability, for the entire duration of utility power outage. All gen-set power ratings are based on temperature rise measured by resistance method as defined by MIL-STD 705C and IEEE STD 115, METHOD 6.4.4. All generators have class H (180°C) insulation system on both rotor and stator windings. All factory tests and KW/KVA charts shown above are based on 120°C (standby) R/R winding temperature, within a maximum 40°C ambient condition. Generators operated at standby power ratings must not exceed the temperature rise limitation for class H insulation system, as specified in NEMA MG1-22.40. Specifications & ratings are subject to change without prior notice.

APPLICATION AND ENGINEERING DATA FOR MODEL SP-2650-60 HZ

GENERATOR SPECIFICATIONS

ManufacturerStamford Electric Generators
 Model & Type S4L1DD-311, 4 Pole, 12 Lead, Three Phase
 HCI434D-17, 4 Pole, 4 Lead, 600V, Three Phase
 Exciter Brushless, shunt excited
 Voltage Regulator Solid State, HZ/Volts
 Voltage Regulation ½%, No load to full load
 Frequency Field convertible, 60 HZ to 50 HZ
 Frequency Regulation ½% (½ cycle, no load to full load)
 Unbalanced Load Capability 100% of standby amps
 Total Stator and Load Insulation Class H, 180°C
 Temperature Rise 120°C R/R, standby rating @ 40°C amb.
 3 Ø Motor Starting @ 30% Voltage Dip (208-240V) 500 kVA
 3 Ø Motor Starting @ 30% Voltage Dip (480V) 780 kVA
 3 Ø Motor Starting @ 30% Voltage Dip (600V) 845 kVA
 Bearing 1, Pre-lubed and sealed
 Coupling Direct flexible disc
 Total Harmonic Distortion Max 3½% (MIL-STD705B)
 Telephone Interference Factor Max 50 (NEMA MG1-22)
 Deviation Factor Max 5% (MIL-STD 405B)
 Ltd. Warranty Period 24 Months from date of start-up or
 1000 hours use, first to occur.

GENERATOR FEATURES

- World Renown Stamford Electric Generator having UL-1446 certification on full amortisseur windings.
- Full generator protection with **Deep Sea 7420** controller, having UL-508 certification.
- Automatic voltage regulator with over-excitation, under-frequency compensation, under-speed protection, and EMI filtering. Entire solid-state board is encapsulated for moisture protection.
- Generator power ratings are based on temperature rise, measured by resistance method, as defined in MIL-STD 705C and IEEE STD 115, Method 6.4.4.
- Power ratings will not exceed temperature rise limitation for class H insulation as per NEMA MG1-22.40.
- Insulation resistance to ground, exceeds 1.5 meg-ohm.
- Stator receives 2000 V. hi-potential test on main windings, and rotor windings receive a 1500 V. hi-potential test, as per MIL-STD 705B.
- Complete engine-generator torsional acceptance, confirmed during initial prototype testing.
- Full load testing on all engine-generator sets, before shipping.
- Self ventilating and drip-proof & revolving field design

ENGINE SPECIFICATIONS AND APPLICATIONS DATA

ENGINE

ManufacturerPower Solutions Inc. (PSI)
 Model and Type Heavy Duty, 14.6LTCAC, 4 cycle
 Aspiration Turbocharged & Charge Air Cooled
 Cylinder Arrangement 8 Cylinders, Vee
 Displacement Cu. In. (Liters) 892 (14.6)
 Bore & Stroke In. (Cm.) 5.04 x 5.59 (12.8 x 14.2)
 Compression Ratio 10.5:1
 Main Bearings & Style 10, Precision Half-Shell
 Cylinder Head Cast Iron
 Pistons Cast Aluminum
 Crankshaft Forged Steel
 Exhaust Valve Inconel, A193
 Governor Electronic
 Frequency Reg. (no load-full load) Isochronous
 Frequency Reg. (steady state) ± 1/4%
 Air Cleaner Dry, Replaceable Cartridge
 Engine Speed 1800
 Piston Speed, ft/min (m./min) 1677 (511)
 Max Power, bhp (kwm) Standby/LPG 253 (189)
 Max Power, bhp (kwm) Standby/NG 402 (300)
 Ltd. Warranty Period 12 Months or 2000 hrs., first to occur

FUEL SYSTEM

TypeLPG or NAT. GAS, Vapor Withdrawal
 Fuel Pressure (kpa), in. H₂O*(1.74-2.74), 7"-11"
 Secondary Fuel Regulator NG or LPG Vapor System
 Auto Fuel Lock-Off Solenoid Standard on all sets
 Fuel Supply Inlet Line (2) 2" NPTF

FUEL CONSUMPTION

LP GAS: FT ³ /HR (M ³ /HR)	STANDBY
100% LOAD	926 (26.2)
75% LOAD	789 (22.4)
50% LOAD	532 (15.1)
LPG = 2500 BTU X FT³/HR = Total BTU/HR LPG Conversion: 8.50 FT³ = 1 LB. : 36.4 FT³ = 1 GAL.	

NAT. GAS: FT ³ /HR (M ³ /HR)	STANDBY
100% LOAD	2782 (78.7)
75% LOAD	2168 (61.4)
50% LOAD	1522 (43.1)
NG = 1000 BTU X FT³/HR = Total BTU/HR	

OIL SYSTEM

Type Full Pressure
 Oil Pan Capacity qt. (L) 42.3 (40.0)
 Oil Pan Cap. W/ filter qt. (L) 49.7 (47.1)
 Oil Filter 2, Replaceable Spin-On

ELECTRICAL SYSTEM

Ignition System Electronic
 Eng. Alternator/Starter: 24 VDC, negative ground, 45 amp/hr.
 Recommended battery to -18°C (0° F):(2) 12 VDC, BCI# 31,
 Max. Dimensions: 14"lg x 6 3/4" wi x 10" hi, with standard
 round posts. Min output 1000 CCA. Battery tray (max. dim. at
 15"lg x 7"wi). This model has (2) battery trays, (2) hold down
 straps, (2) sets of battery cables, and (1) battery charger.
 Installation of (2) 12VDC starting batteries connected in series
 for 24VDC output is required, with possible higher AMP/HR
 rating, as described above, if the normal environment
 temperature averages -13° F (-25°C) or cooler.

APPLICATION AND ENGINEERING DATA FOR MODEL SP-2650-60 HZ

COOLING SYSTEM

Type of System	Pressurized, closed recovery
Coolant Pump	Pre-lubricated, self-sealing
Cooling Fan Type (no. of blades)	Pusher (12)
Fan Diameter inches (mm).....	45" (1143)
Ambient Capacity of Radiator °F (°C).....	125 (51.6)
Engine Jacket Coolant Capacity Gal (L).....	9.5 (43.2)
Radiator Coolant Capacity Gal. (L)	50.0 (227.3)
Maximum Restriction of Cooling Air Intake and discharge side of radiator in. H ₂ O (kpa).....	0.5 (.125)
Water Pump Capacity gpm (L/min).....	180 (680)
Heat Reject Coolant: Btu/min (kw)	16,189 (284)
Low Radiator Coolant Level Shutdown.....	Standard
Note: Coolant temp. shut-down switch setting at 230°F (110°C) with 50/50 (water/antifreeze) mix.	

AIR REQUIREMENTS

Combustion Air, cfm (kg/hr)	532 (1064)
Radiator Air Flow cfm (m ³ /min).....	30,000 (849)
Heat Rejected to Ambient:	
Engine: kw (btu/min).....	66.0 (3765)
Alternator: kw (btu/min).....	23 (1309)

EXHAUST SYSTEM

Exhaust Outlet Size.....	(2) 4"
Max. Back Pressure, in. hg (KPA).....	3.0 (10.2)
Exhaust Flow, at rated kw: cfm (m ³ /min)	2521 (71.3)
Exhaust Temp., at rated kw: °F (°C)	1382 (750)
Engines are EPA certified for Natural Gas.	

SOUND LEVELS MEASURED IN dB(A)

	<u>Open Set</u>	<u>Level 2 Encl.</u>
Level 2, Critical Silencer	93.....	80
Level 3, Hospital Silencer.....		75

Note: Open sets (no enclosure) has (2) optional silencer system choices due to unknown job-site applications. Level 2 enclosure has installed critical silencer with upgrade to hospital silencer. Sound tests are averaged from several test points and taken at 23 ft. (7 m) from source of noise at normal operation.

DERATE GENERATOR FOR ALTITUDE

3% per 1000 ft. (305m) above 3000 ft. (914m) from sea level

DERATE GENERATOR FOR TEMPERATURE

2% per 10°F (5.6°C) above 104F (40°C)

DIMENSIONS AND WEIGHTS

	<u>Open Set</u>	<u>Level 2 Enclosure</u>
Length in (cm).....	152 (368)	186 (473)
Width in (cm).....	72 (183)	72 (183)
Height in (cm).....	80 (203)	94 (239)
3 Ø Net Weight lbs (kg).....	8175 (3708) ...	10675 (4842)
3 Ø Net Weight lbs (kg).....	8525 (3867) ...	11025 (5001)

DEEP SEA 7420 DIGITAL MICROPROCESSOR CONTROLLER



Deep Sea 7420

The "7420" controller is an auto start mains (utility) failure module for single gen-set applications. This controller includes a backlit LCD display which continuously displays the status of the engine and generator at all times.

The "7420" controller will also monitor speed, frequency, voltage, current, oil pressure, coolant temp., and fuel levels. These modules have been designed to display warning and shut down status. It also includes: (11) configurable inputs • (8) configurable outputs • voltage monitoring • mains (utility) failure detection • (250) event logs • configurable timers • automatic shutdown or warning during fault detection • remote start (on load) • engine preheat • advanced metering capability • hour meter • text LCD displays • protected solid state outputs • test buttons for: stop/reset • manual mode • auto mode • lamp test • start button • power monitoring (kWh, kVAr, kVAh, kVArh)

This controller includes expansion features including RS232, RS484 (using MODBUS-RTU/TCP), direct USB connection with PC, expansion optioned using DSENet for remote annunciation and remote relay interfacing for a distance of up to 3300FT. The controller software is freely downloadable from the internet and allows monitoring with direct USB cable, LAN, or by internet via the built in web interface.



Further expansion is available by adding the optional "WebNet" gateway interface module. This device will allow comprehensive monitoring of the generator via the cloud including identification, location, and status. Some advantages of this module include: reduced site visits and maintenance costs • remote fuel management • fault analysis • asset tracking • automatic system alerts • maximized system up-time.

STANDARD FEATURES FOR MODEL SP-2650-60 HZ

STANDARD FEATURES

CONTROL PANEL:

- Deep Sea 7420 digital microprocessor with logic allows programming in the field. Controller has:
- STOP-MANUAL-AUTO modes and automatic engine shutdowns, signaled by full text LCD indicators:
 - Low oil pressure
 - High engine temp
 - Low Radiator Level
 - Three auxiliary alarms
 - Battery fail alarm
 - Engine fail to start
 - Engine over speed
 - Engine under speed
 - Over & under voltage
- Also included is tamper-proof engine hour meter

ENGINE:

- Full flow oil filter • Air filter • Oil pump • Solenoid type starter motor • Hi-temp radiator • Jacket water pump
- Thermostat • Pusher fan and guard • Exhaust manifold
 - 24 VDC battery charging alternator • Flexible exhaust connector • "Isochronous" duty, electronic governor • Secondary dry fuel regulator • Dry fuel lock-off solenoid • Vibration isolators • Closed coolant recovery system with 50/50 water to anti-freeze mixture • flexible oil & radiator drain hose.

AC GENERATOR SYSTEM:

- AC generator • Shunt excited • Brushless design • Circuit Breaker installed and wired to gen-set • Direct connection to engine with flex disc • Class H, 180°C insulation • Self ventilated • Drip proof construction • UL Certified

VOLTAGE REGULATOR:

- ½% Voltage regulation • EMI filter • Under-speed protection • Over-excitation protection • total encapsulation

DC ELECTRICAL SYSTEM:

- Battery tray • Battery cables • Battery hold down straps
- 2-stage battery float charger with maintaining & recharging automatic charge stages

WEATHER/SOUND PROOF ALUMINUM HOUSING CORROSION RESISTANT PROTECTION CONSISTING OF:

- 9 Heated and Agitated Wash Stages
- Zinc Phosphate Etching-coating Stage
- Final Baked On Enamel Powder Coat
- 18/8 Stainless Steel Hardware

Design & specifications subject to change without prior notice. Dimensions shown are approximate. Contact Gillette for certified drawings. DO NOT USE DIMENSIONS FOR INSTALLATION PURPOSES.

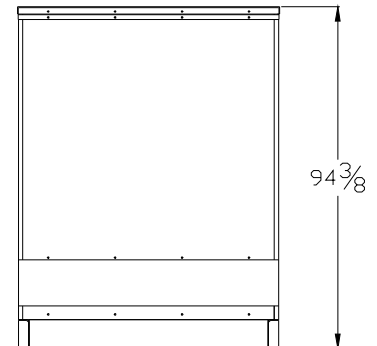
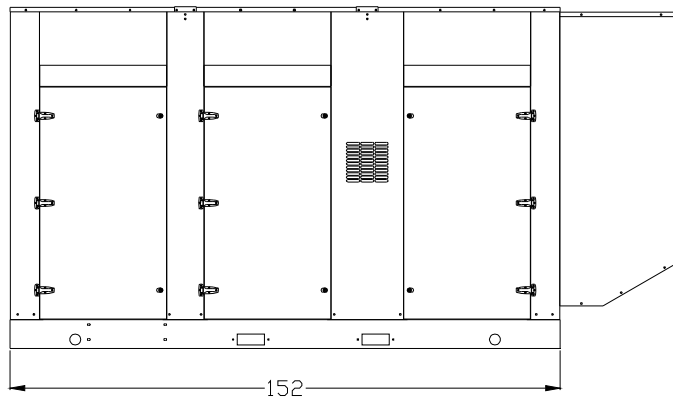
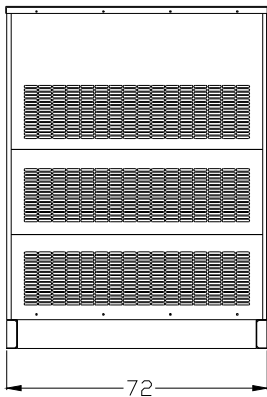
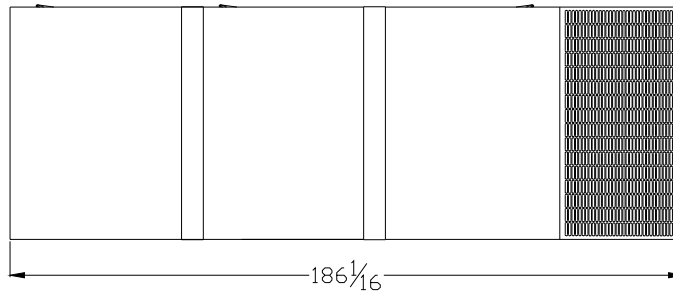



HEAVY-DUTY

14.6L ENGINE

INDUSTRIAL STATIONARY

Product Overview

The PSI HD 14.6L is a U.S. EPA-certified natural gas and propane engine developed from the block up to be a reliable and durable power unit. Built upon a proven marine-diesel grade block, the 6-cylinder in-line, turbocharged and after-cooled engine features replaceable wet liners and water-cooled exhaust.

Superior engine performance is provided by an ECU that integrates and coordinates all critical functions including: Governor, Variable Ignition Timing, Air Fuel Ratio Control, Knock Suppression and Engine Protection.

The PSI HD product lineup has six models with displacements of 8.1L, 11.1L, 14.6L, 18.3L and 21.9L. These engines are an extension of the PSI product line, which is based upon blocks from 650cc to 8.8L. All PSI engines feature the same fuel systems and controls, simplifying your application development and support.

FEATURES

- U.S. EPA-Certified and CARB-Compliant
- Dual Fuel with Automatic Change-Over
- 50C Ambient Cooling Capacity
- 3-Way Catalytic Converter
- Air Filtration
- UL2200-Compliant or Listed Components
- MasterTrak Telematics service (included for 1 year)

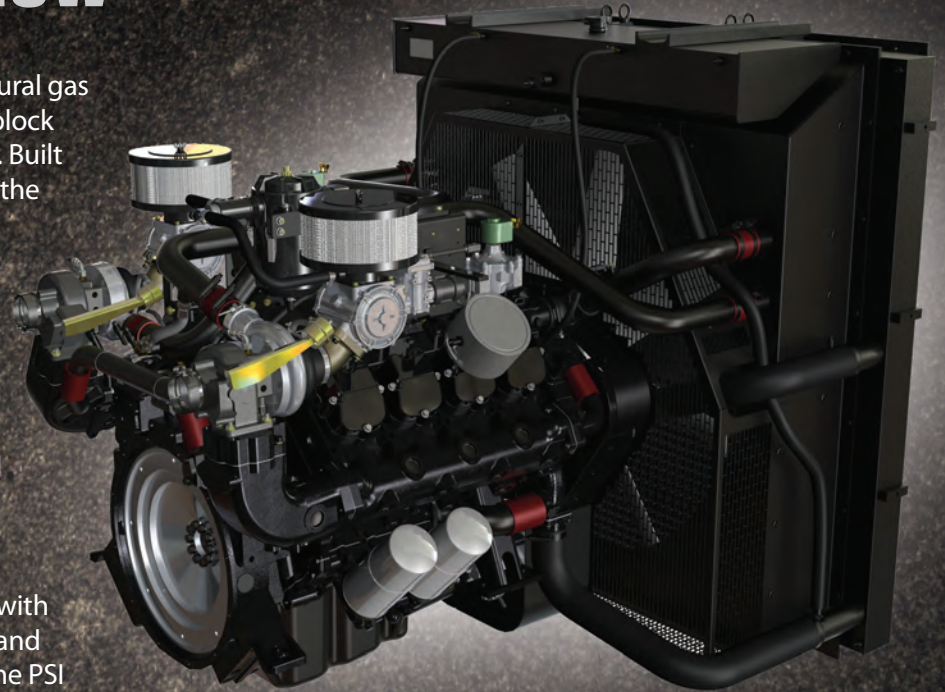

**MAXIMUM
PERFORMANCE
NO COMPROMISES**

POWER & PERFORMANCE • EMISSION-CERTIFIED • FUEL-FLEXIBLE



14.6 L Industrial Stationary Engine

Displacement	892 cid	14,620 cc
Compression Ratio	10.5:1	
Bore & Stroke	5.04 in x 5.59 in	128 mm x 142 mm
kWe	300@1,800 rpm (Natural Gas)	225@1,500 rpm (Natural Gas)
Emission-Certified	EPA, CARB – Industrial Stationary	
Fuel Types	Natural Gas / Propane	

GENERAL DATA

- Water-cooled, turbo-charged, air-to-air inter-cooled, stoichiometric, replaceable wet cylinder liners
- Cast iron block & heads, 10.5:1 compression ratio, overhead valve/2V configuration
- Crankshaft gear-driven oil system with cartridge-type filter, belt-driven centrifugal water pump
- Full ECU engine control including: coil-on-plug variable timing ignition, electronic governor and fuel-air ratio control
- Engine protection for oil pressure, coolant level, coolant temperature, fuel pressure, over-speed
- Complete fuel system for single fuel (NG/LP) operation with closed-loop control
- Alternator (45A/24VDC)
- Starter (24VDC)
- CANBUS J1939 interface

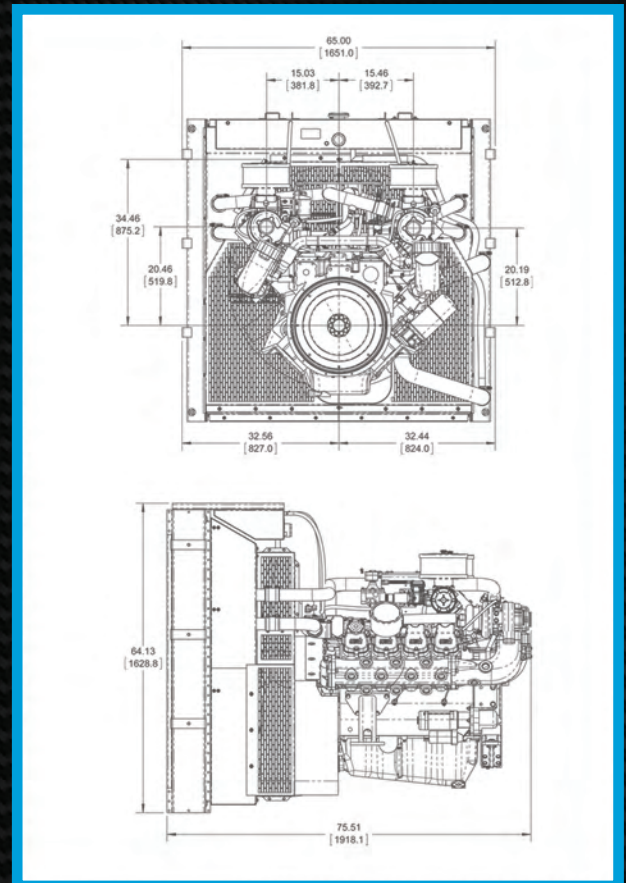

Power shown is gross engine power and has been corrected to SAE J1995. Actual installed power levels may vary depending on the application and OEM supplied components.

STAMFORD

S4L1D-D41 Wdg.311 - Technical Data Sheet

Standards

Stamford industrial alternators meet the requirements of the relevant parts of the BS EN 60034 and the relevant section of other international standards such as BS5000, VDE 0530, NEMA MG1-32, IEC34, CSA C22.2-100 and As1359. Other standards and certifications can be considered on request.

Quality Assurance

Alternators are manufactured using production procedures having a quality assurance level to BS EN ISO 9001.



Excitation and Voltage Regulators

Excitation System					
AVR Type	AS440	MX341	MX321		
Voltage Regulation	± 1%	± 1%	± 0.5%		with 4% Engine Governing
Excitation Type	Self-Excited	PMG	PMG		

No Load Excitation Voltage (V)	12 - 9
No Load Excitation Current (A)	0.7 - 0.5
Full Load Excitation Voltage (V)	41 - 39
Full Load Excitation Current (A)	2.3 - 2.2
Exciter Time Constant (seconds)	0.105

STAMFORD

S4L1D-D41 Wdg.311

Electrical Data								
Insulation System	Class H							
Stator Winding	Double Layer Lap							
Winding Pitch	Two Thirds							
Winding Leads	12							
Winding Number	311							
Number of Poles	4							
IP Rating	IP23							
RFI Suppression	BS EN 61000-6-2 & BS EN 61000-6-4, VDE 0875G, VDE 0875N. Refer to factory for others							
Waveform Distortion	NO LOAD < 1.5% NON-DISTORTING BALANCED LINEAR LOAD < 5.0%							
Short Circuit Ratio	1/Xd							
Steady State X/R Ratio	12.29							
	50 Hz				60 Hz			
Telephone Interference	THF<2%				TIF<50			
Cooling Air	0.83 m³/sec				0.99 m³/sec			
Voltage Star	380	400	415	440	416	440	460	480
kVA Base Rating (Class H) for Reactance Values	300	310	310	290	344	370	375	390
Saturated Values in Per Unit at Base Ratings and Voltages								
Xd Dir. Axis Synchronous	3.15	2.94	2.73	2.27	3.60	3.46	3.21	3.07
X'd Dir. Axis Transient	0.20	0.19	0.17	0.14	0.22	0.21	0.20	0.19
X''d Dir. Axis Subtransient	0.14	0.13	0.12	0.10	0.15	0.14	0.13	0.12
Xq Quad. Axis Reactance	2.66	2.48	2.30	1.92	3.09	2.97	2.75	2.63
X''q Quad. Axis Subtransient	0.40	0.37	0.34	0.29	0.40	0.39	0.36	0.34
XL Stator Leakage Reactance	0.07	0.06	0.06	0.05	0.09	0.08	0.08	0.07
X2 Negative Sequence Reactance	0.27	0.25	0.23	0.19	0.28	0.27	0.25	0.24
X0 Zero Sequence Reactance	0.10	0.09	0.09	0.07	0.10	0.09	0.09	0.08
Unsaturated Values in Per Unit at Base Ratings and Voltages								
Xd Dir. Axis Synchronous	3.78	3.53	3.28	2.73	4.32	4.16	3.85	3.68
X'd Dir. Axis Transient	0.23	0.21	0.20	0.17	0.25	0.24	0.23	0.22
X''d Dir. Axis Subtransient	0.17	0.16	0.15	0.12	0.17	0.16	0.15	0.15
Xq Quad. Axis Reactance	2.74	2.55	2.37	1.97	3.18	3.06	2.84	2.71
X''q Quad. Axis Subtransient	0.48	0.45	0.41	0.34	0.48	0.46	0.43	0.41
XL Stator Leakage Reactance	0.08	0.07	0.07	0.05	0.10	0.09	0.09	0.08
Xlr Rotor Leakage Reactance	0.12	0.11	0.10	0.09	0.14	0.13	0.12	0.12
X2 Negative Sequence Reactance	0.32	0.30	0.28	0.23	0.34	0.32	0.30	0.29
X0 Zero Sequence Reactance	0.12	0.11	0.10	0.08	0.11	0.11	0.10	0.10

STAMFORD®

S4L1D-D41 Wdg.311

Time Constants (Seconds)		
T'd TRANSIENT TIME CONST.	0.08	
T" d SUB-TRANSTIME CONST.	0.019	
T'do O.C. FIELD TIME CONST.	1.7	
Ta ARMATURE TIME CONST.	0.018	
T" q SUB-TRANSTIME CONST.	0.0077	
Resistances in Ohms (Ω) at 22°C		
Stator Winding Resistance (Ra), per phase for series connected	0.0124	
Rotor Winding Resistance (Rf)	1.05	
Exciter Stator Winding Resistance	18	
Exciter Rotor Winding Resistance per phase	0.068	
PMG Phase Resistance (Rpmg) per phase	1.9	
Positive Sequence Resistance (R1)	0.0155	
Negative Sequence Resistance (R2)	0.017856	
Zero Sequence Resistance (R0)	0.0155	
Saturation Factors	400V	480V
SG1.0	0.31	0.31
SG1.2	1.25	1.25
Mechanical Data		
Shaft and Keys	All alternator rotors are dynamically balanced to better than BS6861: Part 1 Grade 2.5 for minimum vibration in operation. Two bearing generators are balanced with a half key.	
	1 Bearing	2 Bearings
SAE Adaptor	SAE 0.5, 1	N/A
Moment of Inertia	4.0771 kgm ²	N/A
Weight Wound Stator	415 kg	N/A
Weight Wound Rotor	361 kg	N/A
Weight Complete Alternator	940 kg	N/A
Shipping weight in a Crate	1010 kg	N/A
Packing Crate Size	155 x 87 x 107(cm)	N/A
Maximum Over Speed	2250 RPM for two minutes	
Bearing Drive End	N/A	N/A
Bearing Non-Drive End	Ball 6314	N/A

STAMFORD®

S4L1D-D41 Wdg.311

THREE PHASE EFFICIENCY CURVES

50Hz

60Hz

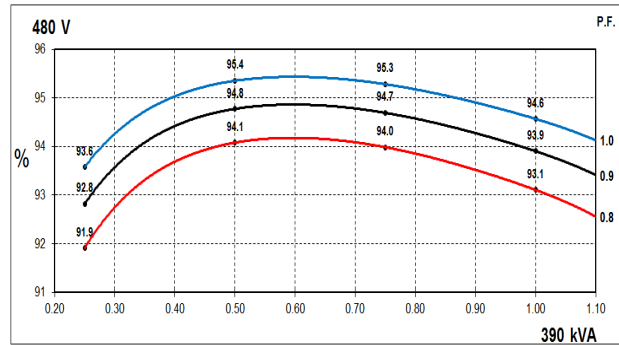
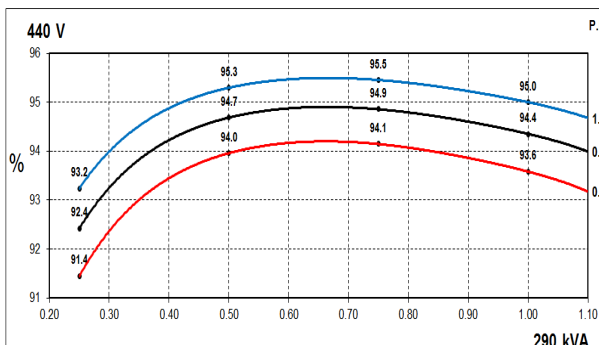
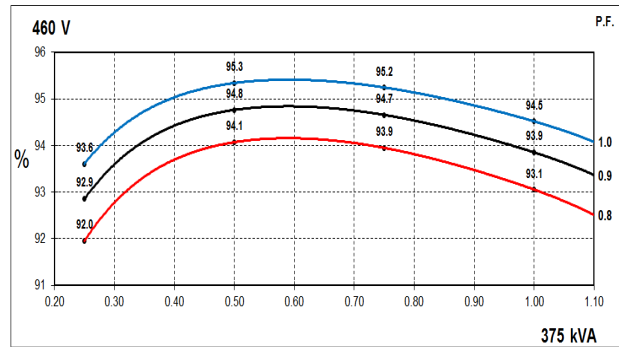
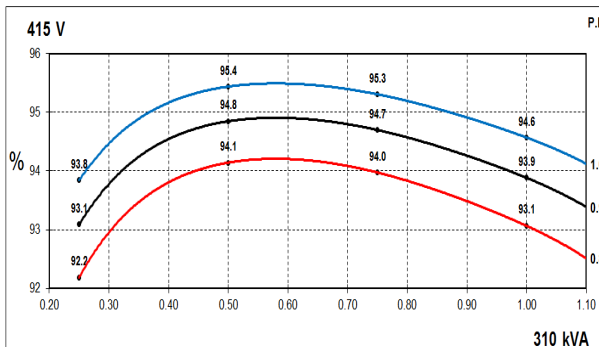
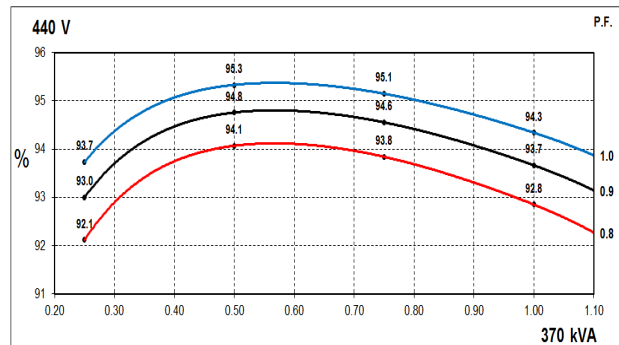
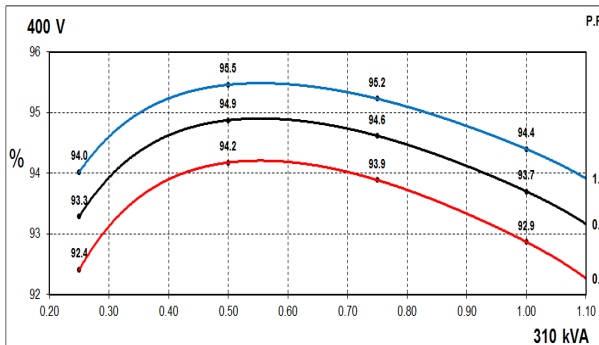
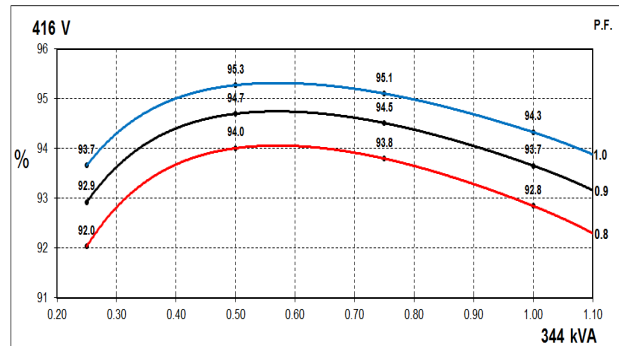
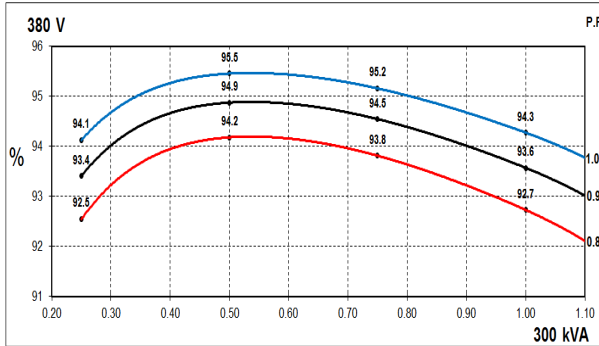

STAMFORD

S4L1D-D41 Wdg.311

Locked Rotor Motor Starting Curves - Separately Excited

50Hz

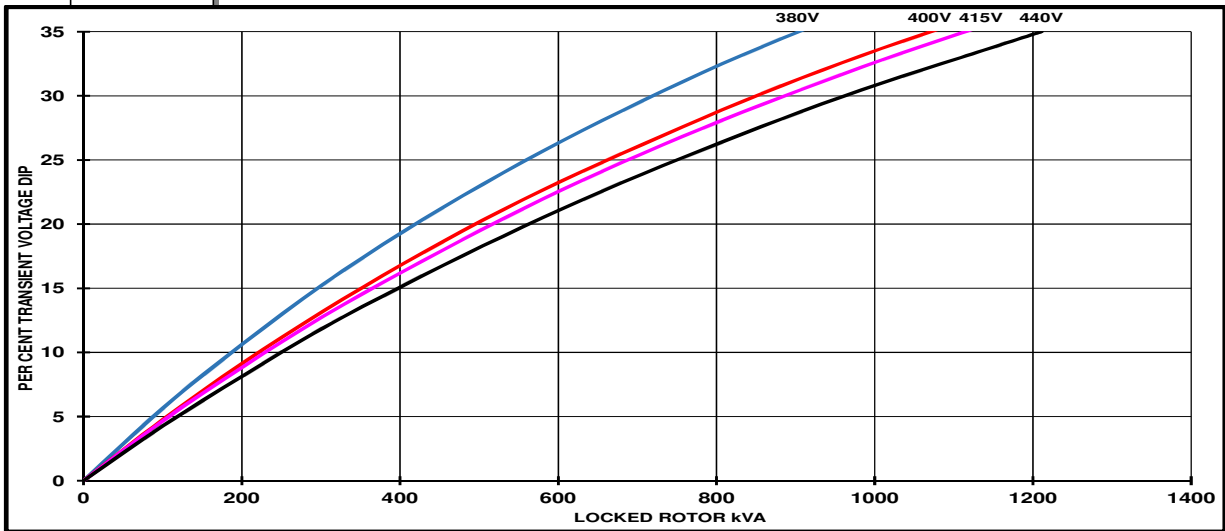

60Hz

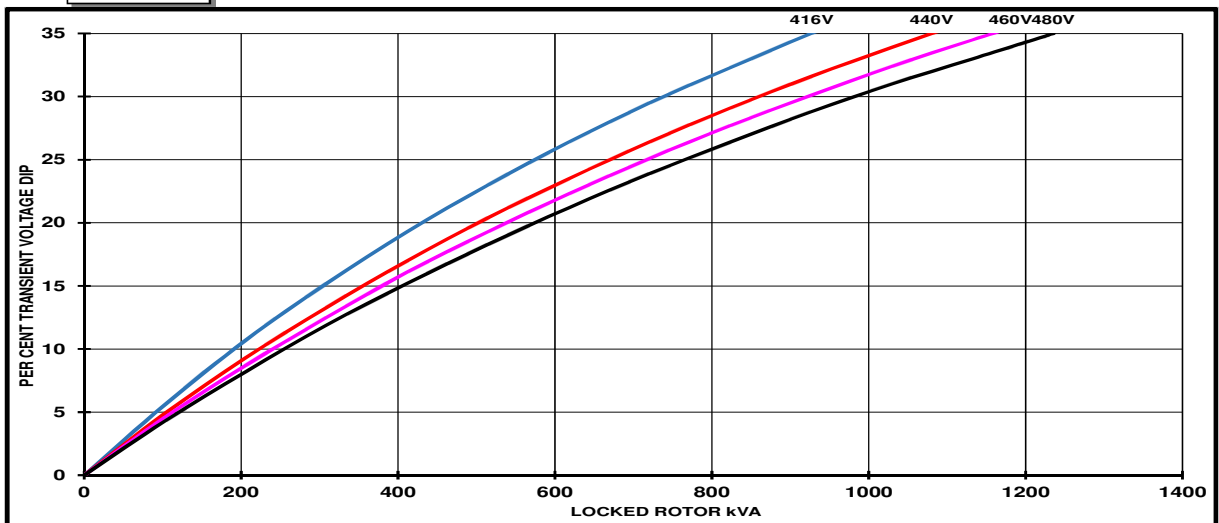

Transient Voltage Dip Scaling Factor		Transient Voltage Rise Scaling Factor
PF	Factor	For voltage rise multiply voltage dip by 1.25
< 0.5	1	
0.5	0.97	
0.6	0.93	
0.7	0.9	
0.8	0.85	
0.9	0.83	

STAMFORD

S4L1D-D41 Wdg.311

Locked Rotor Motor Starting Curves - Self Excited

50Hz

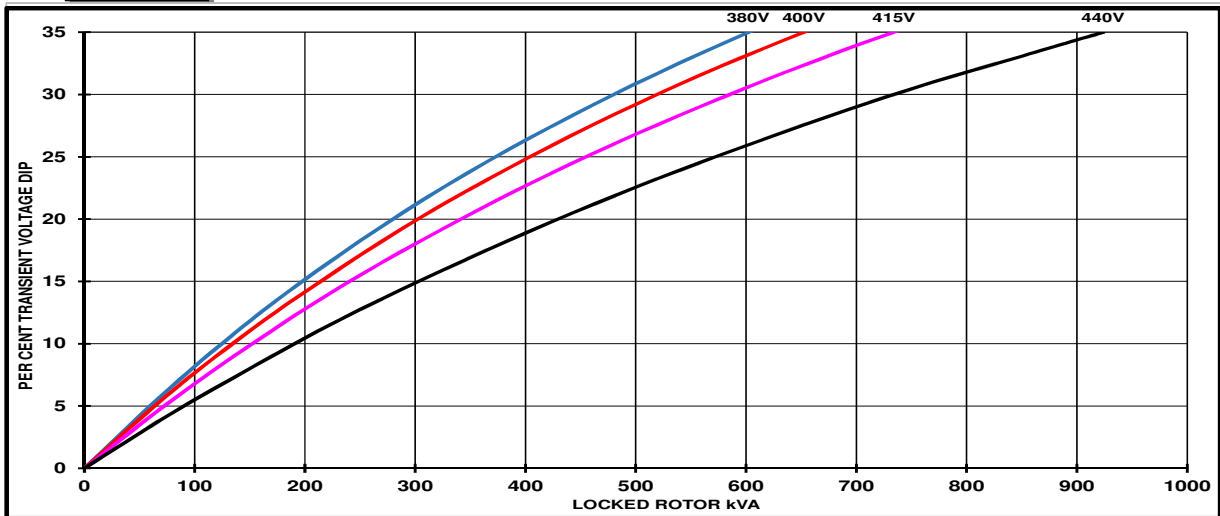

60Hz

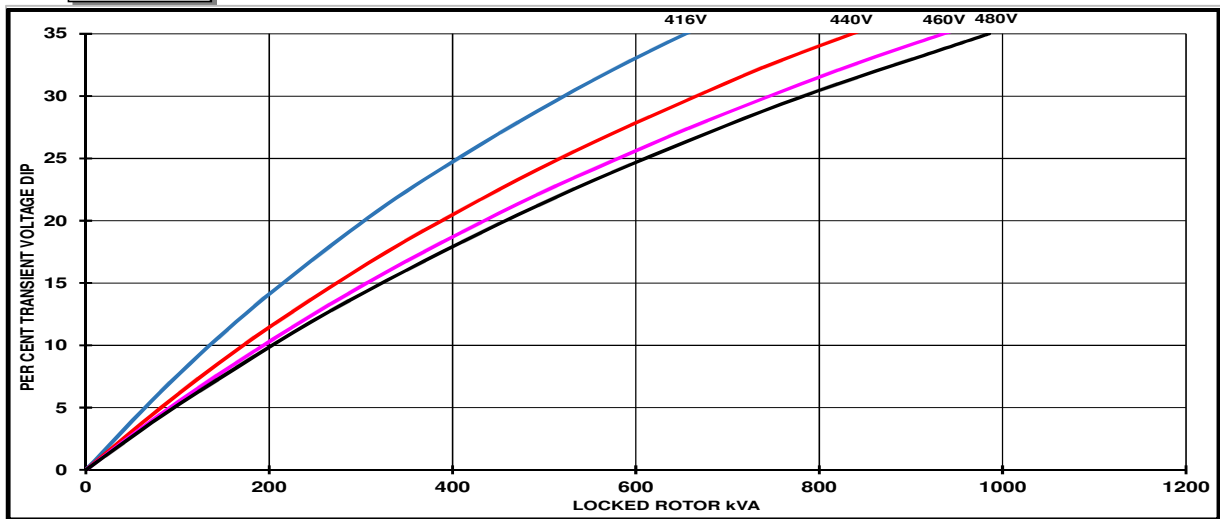

Transient Voltage Dip Scaling Factor		Transient Voltage Rise Scaling Factor
PF	Factor	
< 0.5	1	For voltage rise multiply voltage dip by 1.25
0.5	0.97	
0.6	0.93	
0.7	0.9	
0.8	0.85	
0.9	0.83	

STAMFORD[®]

S4L1D-D41 Wdg.311

Three-phase Short Circuit Decrement Curve

50Hz

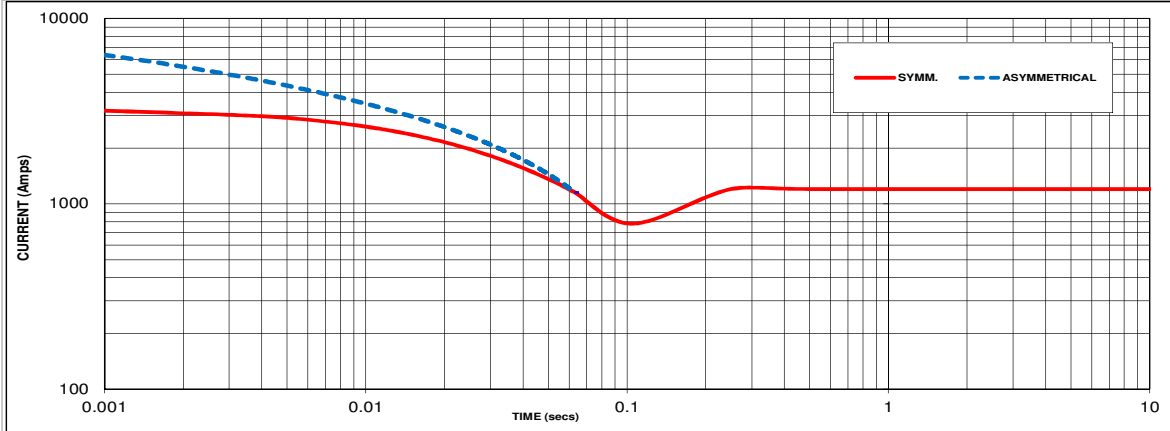

Sustained Short Circuit = 1200 Amps

60Hz

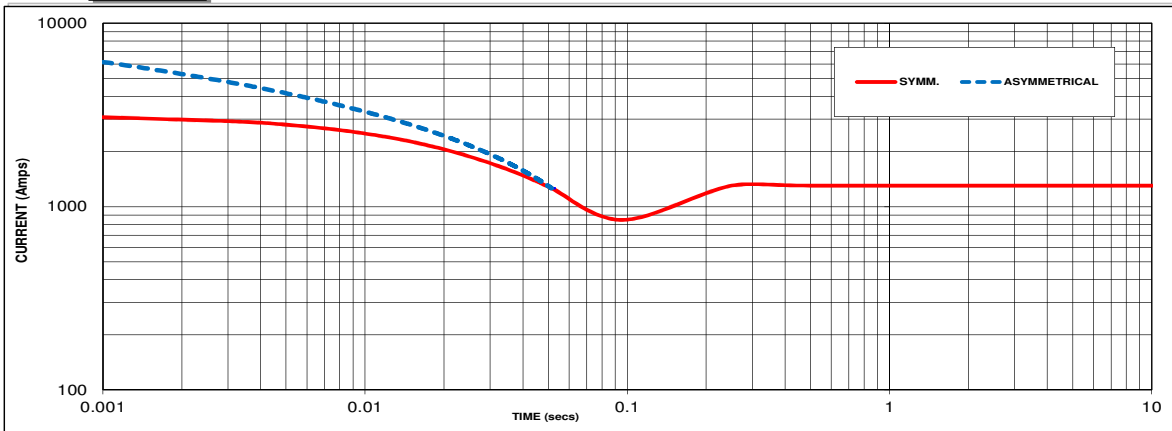

Sustained Short Circuit = 1300 Amps

Note 1

The following multiplication factors should be used to adjust the values from curve between time 0.001 seconds and the minimum current point in respect of nominal operating voltage :

50Hz		60Hz	
Voltage	Factor	Voltage	Factor
380V	X 1.00	416V	X 1.00
400V	X 1.05	440V	X 1.06
415V	X 1.09	460V	X 1.10
440V	X 1.16	480V	X 1.15

The sustained current value is constant irrespective of voltage level

Note 2

The following multiplication factor should be used to convert the values calculated in accordance with NOTE 1 to those applicable to the various types of short circuit :

	3-phase	2-phase L-L	1-phase L-N
Instantaneous	x 1.00	x 0.87	x 1.30
Minimum	x 1.00	x 1.80	x 3.20
Sustained	x 1.00	x 1.50	x 2.50
Max. sustained duration	10 sec.	5 sec.	2 sec.

All other times are unchanged

Note 3

Curves are drawn for Star connected machines under no-load excitation at rated speeds. For other connection the following multipliers should be applied to current values as shown :
 Parallel Star = Curve current value X 2
 Series Delta = Curve current value X 1.732

STAMFORD

S4L1D-D41 Wdg.311

Typical Alternator Operating Charts

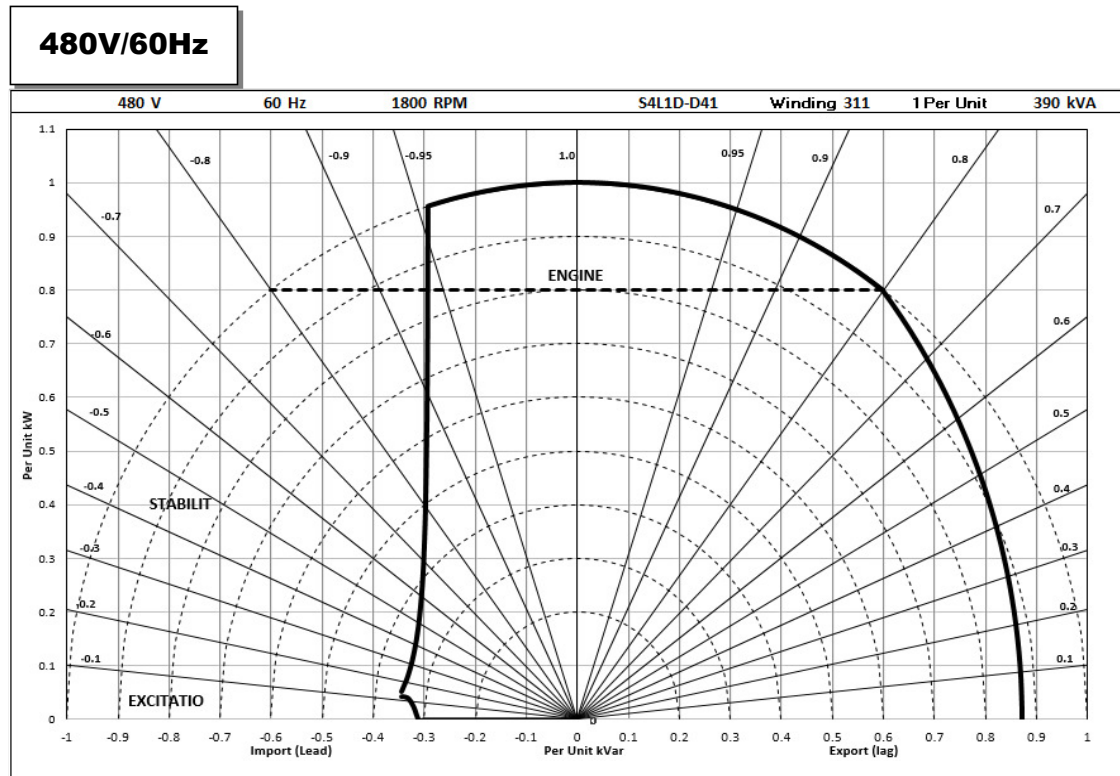
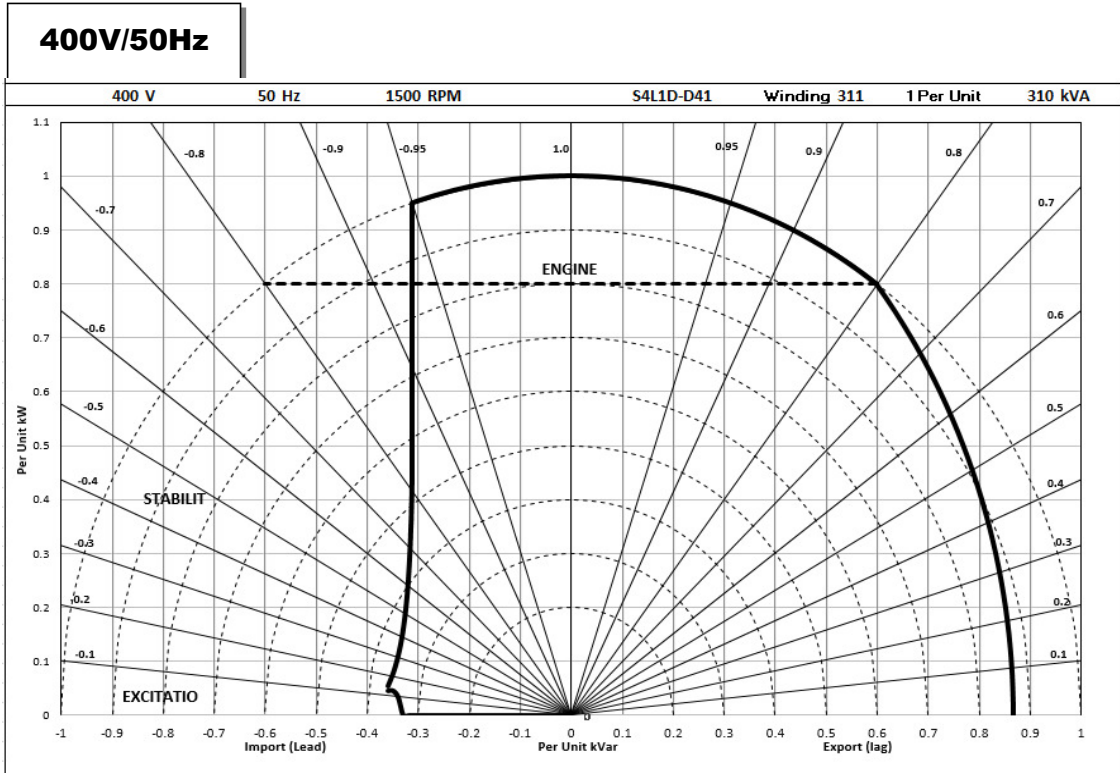

STAMFORD

S4L1D-D41 Wdg.311

RATINGS AT 0.8 POWER FACTOR

Class - Temp Rise		Standby - 163/27°C				Standby - 150/40°C				Cont. H - 125/40°C				Cont. F - 105/40°C			
50 Hz	Series Star (V)	380	400	415	440	380	400	415	440	380	400	415	440	380	400	415	440
	kVA	330	340	340	320	320	330	330	310	300	310	310	290	280	285	285	270
	kW	264	272	272	256	256	264	264	248	240	248	248	232	224	228	228	216
	Efficiency (%)	92.1	92.3	92.6	93.2	92.3	92.5	92.7	93.3	92.7	92.9	93.1	93.6	93.1	93.3	93.4	93.8
	kW Input	287	295	294	275	277	285	285	266	259	267	266	248	241	244	244	230

60 Hz	Series Star (V)	416	440	460	480	416	440	460	480	416	440	460	480	416	440	460	480
	kVA	375	410	415	430	365	400	400	415	344	370	375	390	315	340	345	355
	kW	300	328	332	344	292	320	320	332	275	296	300	312	252	272	276	284
	Efficiency (%)	92.4	92.2	92.5	92.6	92.5	92.4	92.7	92.8	92.8	92.9	93.1	93.1	93.2	93.2	93.4	93.5
	kW Input	325	356	359	372	316	346	345	358	296	319	322	335	270	292	295	304

De-Rates

All values tabulated above are subject to the following reductions:

- 5% when air inlet filters are fitted
- 3% for every 500 meters by which the operating altitude exceeds 1000 meters above mean sea level
- 3% for every 5°C by which the operational ambient temperature exceeds 40°C
- For any other operating conditions impacting the cooling circuit please refer to applications

Note: Requirement for operating in an ambient exceeding 60°C and altitude exceeding 4000 meters must be referred to applications.

Dimensional and Torsional Drawing

For dimensional and torsional information please refer to the alternator General Arrangement and rotor drawings available on our website (<http://stamford-avk.com/>)

Note: Continuous development of our products means that the information contained in our data sheets can change without notice, and specifications should always be confirmed with Cummins Generator Technologies prior to purchase.



Follow us @stamfordavk



Cummins Generator Technologies



View our videos at youtube.com/stamfordavk

news.stamford-avk.com

For Applications Support:
applications@cummins.com

For Customer Service:
service-engineers@stamford-avk.com

For General Enquiries:
info@cumminsgeneratortechnologies.com

Copyright 2016. Cummins Generator Technologies Ltd. All rights reserved.
Cummins and the Cummins logo are registered trade marks of Cummins Inc.
STAMFORD is a registered trade mark of Cummins Generator Technologies Ltd.



STAMFORD®

HCI434D/444D - Winding 17

Technical  Data Sheet

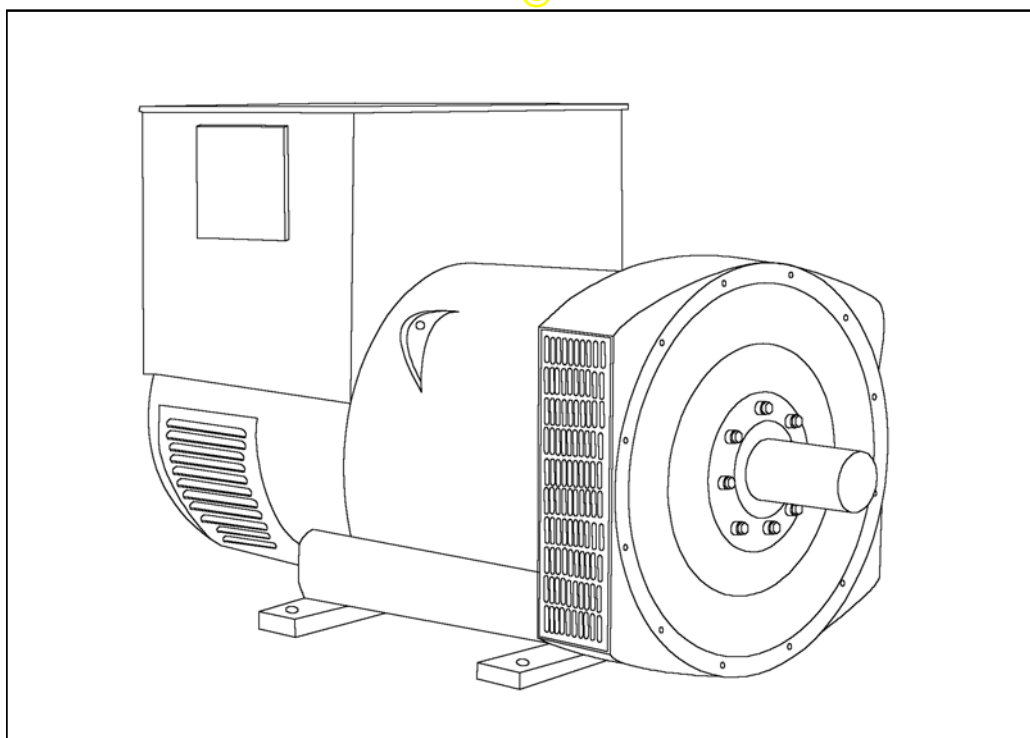

HCI434D/444D

SPECIFICATIONS & OPTIONS

STAMFORD

STANDARDS

Stamford industrial generators meet the requirements of BS EN 60034 and the relevant section of other international standards such as BS5000, VDE 0530, NEMA MG1-32, IEC34, CSA C22.2-100, AS1359. Other standards and certifications can be considered on request.

VOLTAGE REGULATORS

AS440 AVR - STANDARD

With this self-excited system the main stator provides power via the Automatic Voltage Regulator (AVR) to the exciter stator. The high efficiency semi-conductors of the AVR ensure positive build-up from initial low levels of residual voltage.

The exciter rotor output is fed to the main rotor through a three-phase full-wave bridge rectifier. The rectifier is protected by a surge suppressor against surges caused, for example, by short circuit or out-of-phase paralleling.

The AS440 will support a range of electronic accessories, including a 'droop' Current Transformer (CT) to permit parallel operation with other ac generators.

MX341 AVR

This sophisticated AVR is incorporated into the Stamford Permanent Magnet Generator (PMG) control system.

The PMG provides power via the AVR to the main exciter, giving a source of constant excitation power independent of generator output. The main exciter output is then fed to the main rotor, through a full wave bridge, protected by a surge suppressor. The AVR has in-built protection against sustained over-excitation, caused by internal or external faults. This de-excites the machine after a minimum of 5 seconds.

An engine relief load acceptance feature can enable full load to be applied to the generator in a single step.

If three-phase sensing is required with the PMG system the MX321 AVR must be used.

We recommend three-phase sensing for applications with greatly unbalanced or highly non-linear loads.

MX321 AVR

The most sophisticated of all our AVRs combines all the features of the MX341 with, additionally, three-phase rms sensing, for improved regulation and performance.

Over voltage protection is built-in and short circuit current level adjustments is an optional facility.

WINDINGS & ELECTRICAL PERFORMANCE

All generator stators are wound to 2/3 pitch. This eliminates triplen (3rd, 9th, 15th ...) harmonics on the voltage waveform and is found to be the optimum design for trouble-free supply of non-linear loads. The 2/3 pitch design avoids excessive neutral currents sometimes seen with higher winding pitches, when in parallel with the mains. A fully connected damper winding reduces oscillations during paralleling. This winding, with the 2/3 pitch and carefully selected pole and tooth designs, ensures very low waveform distortion.

TERMINALS & TERMINAL BOX

Standard generators are 3-phase reconnectable with 12 ends brought out to the terminals, which are mounted on a cover at the non-drive end of the generator. A sheet steel terminal box contains the AVR and provides ample space for the customers' wiring and gland arrangements. It has removable panels for easy access.

SHAFT & KEYS

All generator rotors are dynamically balanced to better than BS6861:Part 1 Grade 2.5 for minimum vibration in operation. Two bearing generators are balanced with a half key.

INSULATION/IMPREGNATION

The insulation system is class 'H'.

All wound components are impregnated with materials and processes designed specifically to provide the high build required for static windings and the high mechanical strength required for rotating components.

QUALITY ASSURANCE

Generators are manufactured using production procedures having a quality assurance level to BS EN ISO 9001.

The stated voltage regulation may not be maintained in the presence of certain radio transmitted signals. Any change in performance will fall within the limits of Criteria 'B' of EN 61000-6-2:2001. At no time will the steady-state voltage regulation exceed 2%.

DE RATES

All values tabulated on page 6 are subject to the following reductions

5% when air inlet filters are fitted.

3% for every 500 metres by which the operating altitude exceeds 1000 metres above mean sea level.

3% for every 5 C by which the operational ambient temperature exceeds 40 C.

Note: Requirement for operating in an ambient exceeding 60 C must be referred to the factory.

NB Continuous development of our products entitles us to change specification details without notice, therefore they must not be regarded as binding.

Front cover drawing typical of product range.

APPROVED DOCUMENT

HCI434D/444D

STAMFORD

WINDING 17

CONTROL SYSTEM	SEPARATELY EXCITED BY P.M.G.		
A.V.R.	MX321	MX341	
VOLTAGE REGULATION	± 0.5 %	± 1.0 %	With 4% ENGINE GOVERNING
SUSTAINED SHORT CIRCUIT	REFER TO SHORT CIRCUIT DECREMENT CURVES (page 5)		
CONTROL SYSTEM	SELF EXCITED		
A.V.R.	AS440		
VOLTAGE REGULATION	± 1.0 %		With 4% ENGINE GOVERNING
SUSTAINED SHORT CIRCUIT	WILL NOT SUSTAIN A SHORT CIRCUIT		
INSULATION SYSTEM	CLASS H		
PROTECTION	IP23		
RATED POWER FACTOR	0.8		
STATOR WINDING	DOUBLE LAYER LAP		
WINDING PITCH	TWO THIRDS		
WINDING LEADS	12		
STATOR WDG. RESISTANCE	0.02 Ohms PER PHASE AT 22°C SERIES STAR CONNECTED		
ROTOR WDG. RESISTANCE	1.05 Ohms at 22°C		
EXCITER STATOR RESISTANCE	18 Ohms at 22°C		
EXCITER ROTOR RESISTANCE	0.068 Ohms PER PHASE AT 22°C		
R.F.I. SUPPRESSION	BS EN 61000-6-2 & BS EN 61000-6-4, VDE 0875G, VDE 0875N. refer to factory for others		
WAVEFORM DISTORTION	NO LOAD < 1.5% NON-DISTORTING BALANCED LINEAR LOAD < 5.0%		
MAXIMUM OVERSPEED	2250 Rev/Min		
BEARING DRIVE END	BALL. 6317 (ISO)		
BEARING NON-DRIVE END	BALL. 6314 (ISO)		
	1 BEARING	2 BEARING	
WEIGHT COMP. GENERATOR	940 kg	950 kg	
WEIGHT WOUND STATOR	415 kg	415 kg	
WEIGHT WOUND ROTOR	361 kg	338 kg	
WR ² INERTIA	4.0771 kgm ²	3.8783 kgm ²	
SHIPPING WEIGHTS in a crate	1010 kg	1010 kg	
PACKING CRATE SIZE	155 x 87 x 107(cm)	155 x 87 x 107(cm)	
TELEPHONE INTERFERENCE	THF<2%	TIF<50	
COOLING AIR	0.99 m ³ /sec 2100 cfm		
VOLTAGE SERIES STAR	600V		
VOLTAGE PARALLEL STAR	300V		
VOLTAGE SERIES DELTA	346V		
KVA BASE RATING FOR REACTANCE VALUES	375		
X _d DIR. AXIS SYNCHRONOUS	2.96		
X' _d DIR. AXIS TRANSIENT	0.18		
X'' _d DIR. AXIS SUBTRANSIENT	0.13		
X _q QUAD. AXIS REACTANCE	2.54		
X'' _q QUAD. AXIS SUBTRANSIENT	0.34		
X _L LEAKAGE REACTANCE	0.07		
X ₂ NEGATIVE SEQUENCE	0.22		
X ₀ ZERO SEQUENCE	0.08		
REACTANCES ARE SATURATED		VALUES ARE PER UNIT AT RATING AND VOLTAGE INDICATED	
T' _d TRANSIENT TIME CONST.	0.08s		
T'' _d SUB-TRANSTIME CONST.	0.019s		
T' _{do} O.C. FIELD TIME CONST.	1.7s		
T _a ARMATURE TIME CONST.	0.018s		
SHORT CIRCUIT RATIO	1/X _d		

HCI434D/444D

STAMFORD

Winding 17

SX

Locked Rotor Motor Starting Curves

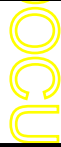
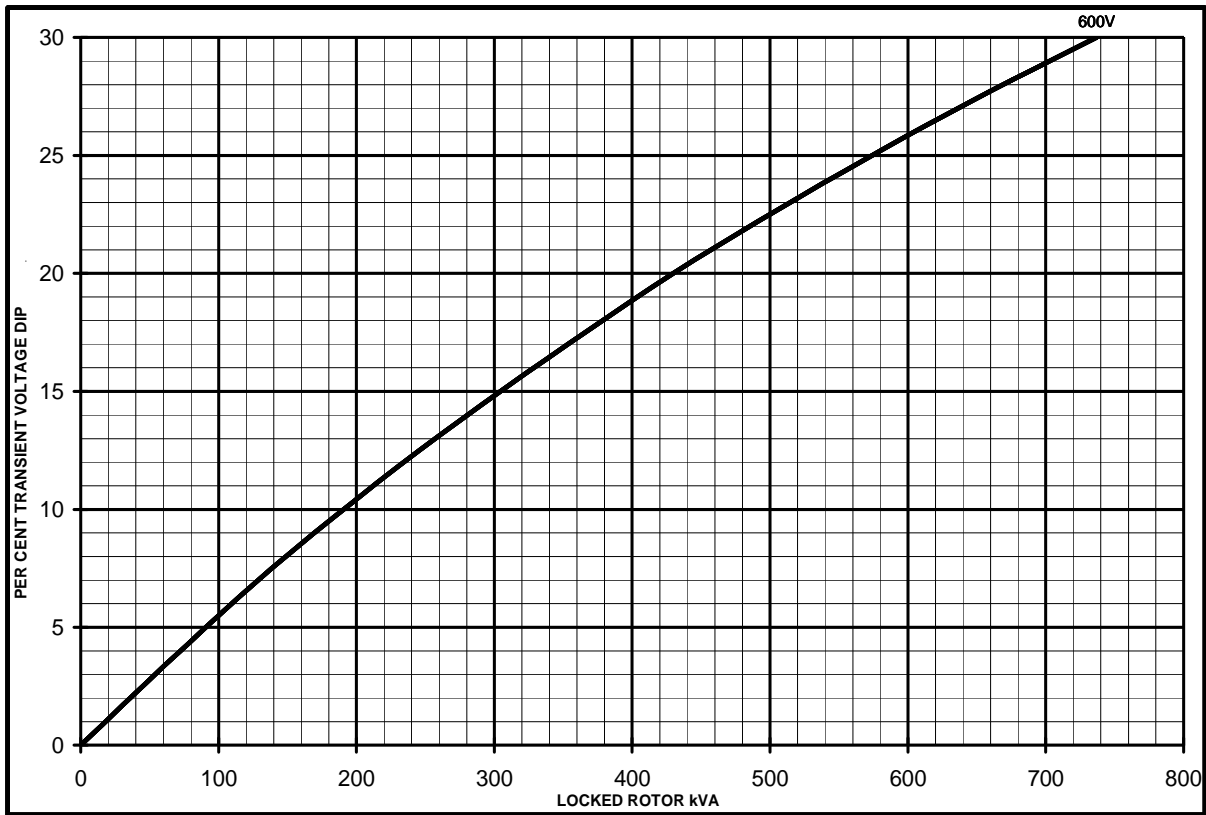

MX

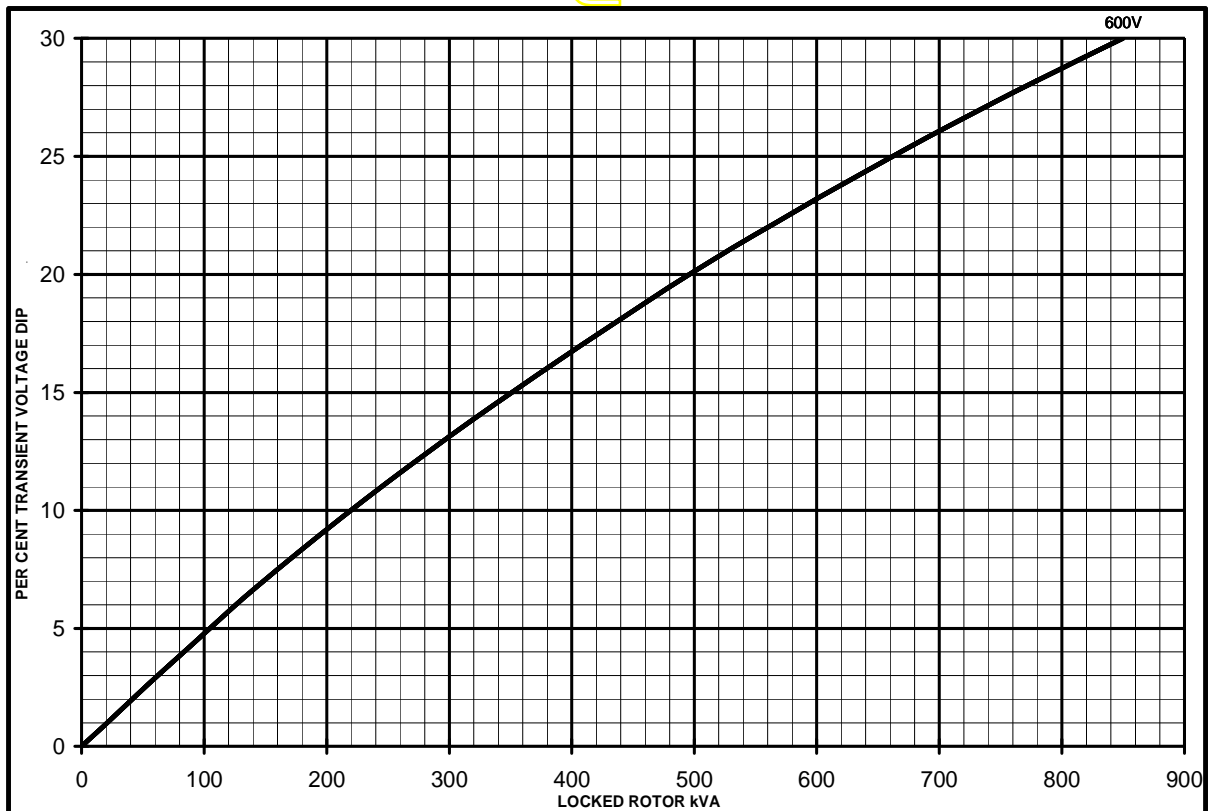

HCI434D/444D
Winding 17

STAMFORD

THREE PHASE EFFICIENCY CURVES

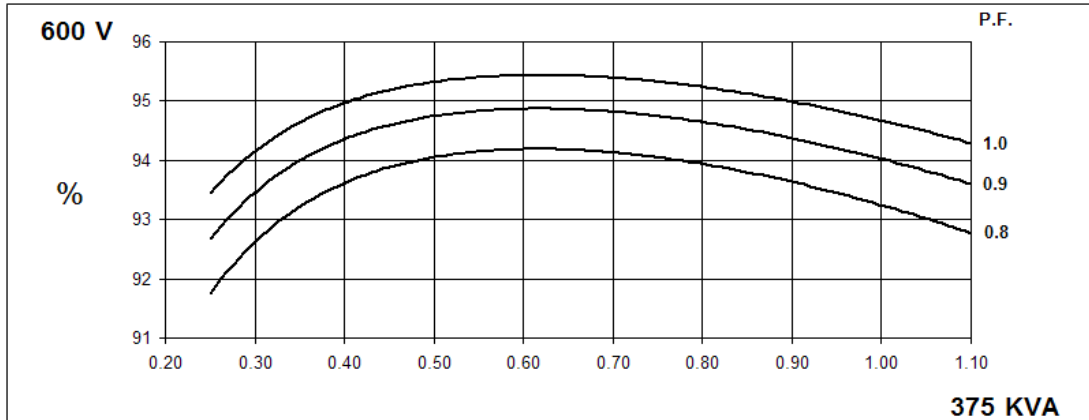

Three-phase Short Circuit Decrement Curve. No-load Excitation at Rated Speed Based on star (wye) connection.

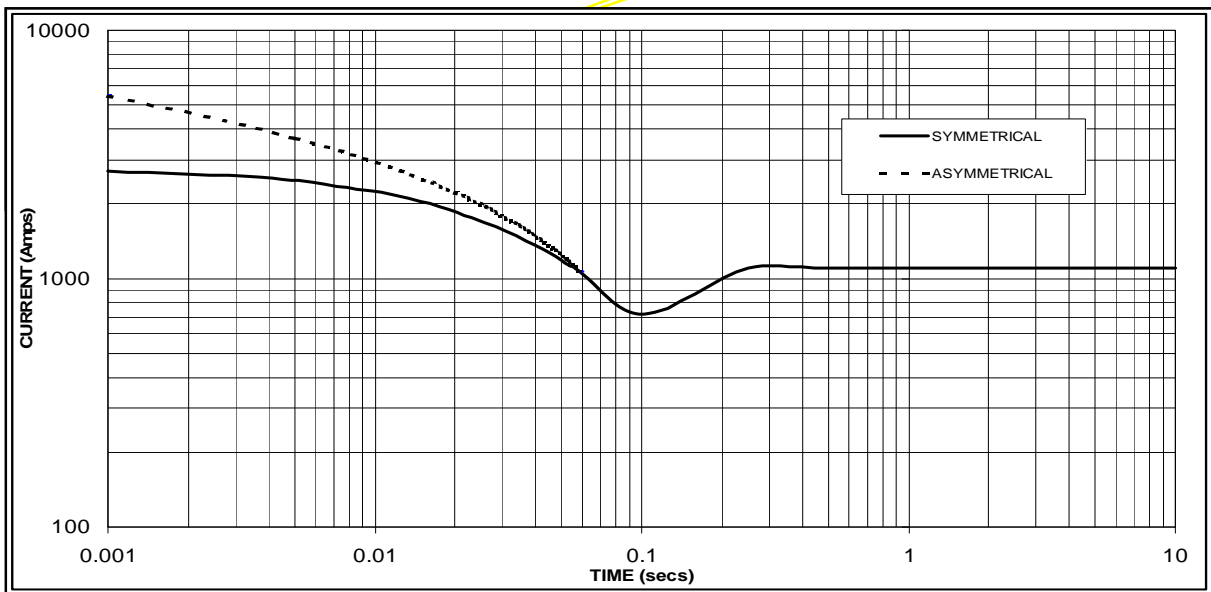

Sustained Short Circuit = 1100 Amps

Note

The following multiplication factor should be used to convert the values from curve for the various types of short circuit :

	3-phase	2-phase L-L	1-phase L-N
Instantaneous	x 1.00	x 0.87	x 1.30
Minimum	x 1.00	x 1.80	x 3.20
Sustained	x 1.00	x 1.50	x 2.50
Max. sustained duration	10 sec.	5 sec.	2 sec.

All other times are unchanged

HCI434D/444D

Winding 17 / 0.8 Power Factor

STAMFORD

60Hz

RATINGS

Class - Temp Rise	Cont. F - 105/40°C	Cont. H - 125/40°C	Standby - 150/40°C	Standby - 163/27°C
Series Star (V)	600	600	600	600
Parallel Star (V)	300	300	300	300
Series Delta (V)	346	346	346	346
kVA	345	375	400	415
kW	276	300	320	332
Efficiency (%)	93.6	93.2	92.9	92.7
kW Input	295	322	344	358

APPROVED

DIMENSIONS

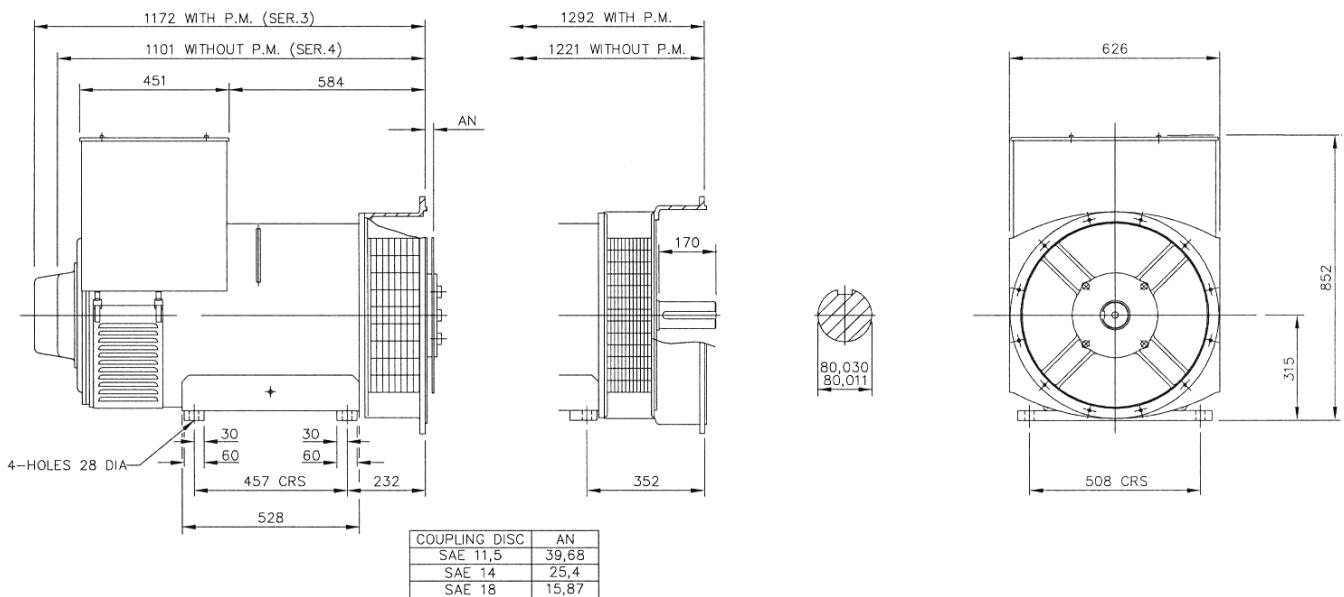

APPROVED DOCUMENT

STAMFORD

Head Office Address:
Barnack Road, Stamford
Lincolnshire, PE9 2NB
United Kingdom
Tel: +44 (0) 1780 484000
Fax: +44 (0) 1780 484100

www.cumminsgeneratortechnologies.com

Copyright 2010, Cummins Generator Technologies Ltd, All Rights Reserved
Stamford and AvK are registered trade marks of Cummins Generator Technologies Ltd
Cummins and the Cummins logo are registered trade marks of Cummins Inc.

DSE7410/20

AUTO START & AUTO MAINS FAILURE MODULES

FEATURES

The DSE7410 is an Auto Start Control Module and the **DSE7420** is an Auto Mains (Utility) Failure Control Module suitable for a wide variety of single, diesel or gas, gen-set applications.

A sophisticated module monitoring an extensive number of engine parameters, the DSE74xx will announce warnings, shutdown and engine status information on the back-lit LCD screen, illuminated LED, remote PC, audible alarm and via SMS text alerts. The module includes RS232, RS485 & Ethernet ports as well as dedicated terminals for system expansion.

The DSE7400 Series modules are compatible with electronic (CAN) and non-electronic (magnetic pick-up/alternator sensing) engines and offer a comprehensive number of flexible inputs, outputs and extensive engine protections so the system can be easily adapted to meet the most demanding industry paralleling requirements.

The modules can be easily configured using the DSE Configuration Suite Software. Selected front panel editing is also available.

ENVIRONMENTAL TESTING STANDARDS

ELECTRO-MAGNETIC COMPATIBILITY

BS EN 61000-6-2
EMC Generic Immunity Standard for the Industrial Environment
BS EN 61000-6-4
EMC Generic Emission Standard for the Industrial Environment

ELECTRICAL SAFETY

BS EN 60950
Safety of Information Technology Equipment, including Electrical Business Equipment

TEMPERATURE

BS EN 60068-2-1
Ab/Ae Cold Test -30 °C
BS EN 60068-2-2
Bb/Be Dry Heat +70 °C

VIBRATION

BS EN 60068-2-6
Ten sweeps in each of three major axes
5 Hz to 8 Hz @ +/-7.5 mm,
8 Hz to 500 Hz @ 2 gn

HUMIDITY

BS EN 60068-2-30
Db Damp Heat Cyclic 20/55 °C @ 95% RH 48 Hours
BS EN 60068-2-78
Cab Damp Heat Static 40 °C @ 93% RH 48 Hours

SHOCK

BS EN 60068-2-27
Three shocks in each of three major axes
15 gn in 11 ms

DEGREES OF PROTECTION PROVIDED BY ENCLOSURES

BS EN 60529
IP65 - Front of module when installed into the control panel with the supplied sealing gasket.

COMPREHENSIVE FEATURE LIST TO SUIT A WIDE VARIETY OF GEN-SET APPLICATIONS

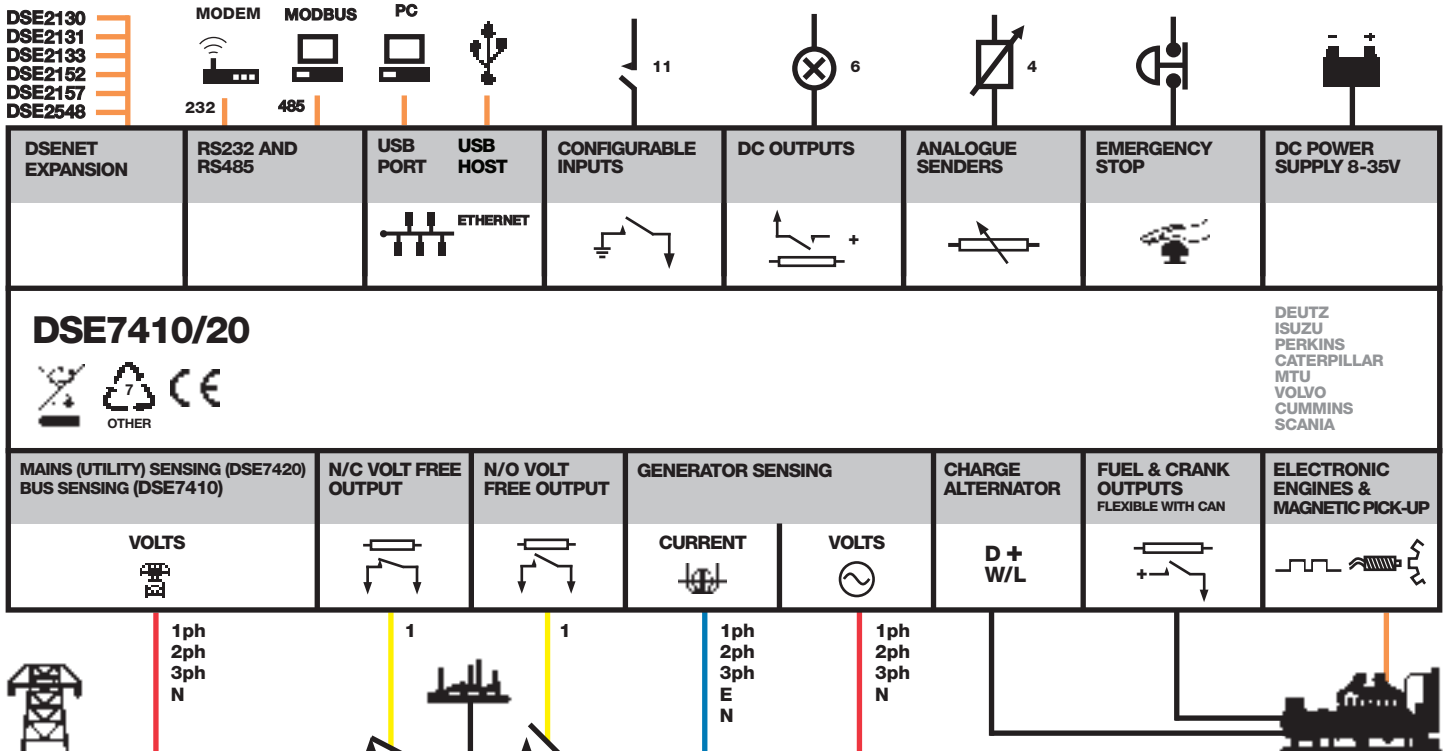

DSE7410/20

AUTO START & AUTO MAINS FAILURE MODULES

FEATURES



DSE7420

DSE7410



KEY FEATURES

- Configurable inputs (11)
- Configurable outputs (8)
- Voltage measurement
- Mains (utility) failure detection
- Dedicated load test button
- kW overload alarms
- Comprehensive electrical protection
- RS232, RS485 & Ethernet remote communications
- Modbus RTU/TCP
- PLC functionality
- Multi event exercise timer
- Back-lit LCD 4-line text display
- Multiple display languages
- Automatic start/Manual start
- Audible alarm
- Fixed and flexible LED indicators
- Event log (250)
- Engine protection
- Fault condition notification to a designated PC
- Front panel mounting
- Protected front panel programming
- Configurable alarms and timers
- Configurable start and stop timers

- Five key menu navigation
- Front panel editing with PIN protection
- 3 configurable maintenance alarms
- CAN and magnetic pick-up/Alt. sensing
- Fuel usage monitor and low fuel alarms
- Charge alternator failure alarm
- Manual speed control (on compatible CAN engines)
- Manual fuel pump control
- "Protections disabled" feature
- Reverse power protection
- Power monitoring (kW h, kV Ar, kV A h, kV Ar h)
- Load switching (load shedding and dummy load outputs)
- Automatic load transfer (DSE7420)
- Unbalanced load protection
- Independent earth fault trip
- Fully configurable via DSE Configuration Suite PC software
- Configurable display languages
- Remote SCADA monitoring via DSE Configuration Suite PC software

- Advanced SMS messaging (additional external modem required)
- Start & stop capability via SMS messaging
- Additional display screens to help with modem diagnostics
- DSENet® expansion
- Integral PLC editor

KEY BENEFITS

- RS232, RS485 & Ethernet can be used at the same time
- DSENet® connection for system expansion
- PLC functionality
- Five step dummy load support
- Five step load shedding support
- High number of inputs and outputs
- Worldwide language support
- Direct USB connection to PC
- Ethernet monitoring
- USB host
- Data logging & trending

RELATED MATERIALS

TITLE

DSE7410 Installation Instructions
DSE7420 Installation Instructions
 DSE74xx Quick Start Guide
 DSE74xx Operator Manual
 DSE74xx PC Configuration Suite Manual

PART NO'S

053-085
 053-088
 057-162
 057-161
 057-160

SPECIFICATION

DC SUPPLY

CONTINUOUS VOLTAGE RATING
 8 V to 35 V Continuous

CRANKING DROPOUTS

Able to survive 0 V for 50 mS, providing supply was at least 10 V before dropout and supply recovers to 5 V. This is achieved without the need for internal batteries

MAXIMUM OPERATING CURRENT

260 mA at 12 V, 130 mA at 24 V

MAXIMUM STANDBY CURRENT

120 mA at 12 V, 65 mA at 24 V

CHARGE FAIL/EXCITATION RANGE

0 V to 35 V

OUTPUTS

OUTPUT A (FUEL)

15 A DC at supply voltage

OUTPUT B (START)

15 A DC at supply voltage

OUTPUTS C & D

8 A AC at 250 V AC (Volt free)

AUXILIARY OUTPUTS E,F,G,H,I & J

2 A DC at supply voltage

GENERATOR

VOLTAGE RANGE

15 V to 333 V AC (L-N)

FREQUENCY RANGE

3.5 Hz to 75 Hz

MAINS (UTILITY) (DSE7420)

VOLTAGE RANGE

15 V to 333 V AC (L-N)

FREQUENCY RANGE

3.5 Hz to 75 Hz

BUS (DSE7410)

VOLTAGE RANGE

15 V to 333 V AC (L-N)

FREQUENCY RANGE

3.5 Hz to 75 Hz

MAGNETIC PICK UP

VOLTAGE RANGE

+/- 0.5 V to 70 V

FREQUENCY RANGE

10,000 Hz (max)

DIMENSIONS

OVERALL

240 mm x 172 mm x 57 mm
 9.4" x 6.8" x 2.2"

PANEL CUTOUT

220 mm x 160 mm
 8.7" x 6.3"

MAXIMUM PANEL THICKNESS

8 mm
 0.3"

STORAGE TEMPERATURE RANGE

-40 °C to +85 °C

DEEP SEA ELECTRONICS PLC UK

Highfield House, Hunmanby Industrial Estate, Hunmanby YO14 0PH
TELEPHONE +44 (0) 1723 890099 **FACSIMILE** +44 (0) 1723 893303
EMAIL sales@deepseapl.com **WEBSITE** www.deepseapl.com

DEEP SEA ELECTRONICS INC USA

3230 Williams Avenue, Rockford, IL 61101-2668 USA
TELEPHONE +1 (815) 316 8706 **FACSIMILE** +1 (815) 316 8708
EMAIL sales@deepseausa.com **WEBSITE** www.deepseausa.com

Tmax-Molded Case Circuit Breakers

T5 400A and 600A Frame

AC Circuit Breakers and Switches

DC Circuit Breakers and Switches (400A Only)

3 and 4 Pole

Motor Circuit Protectors

Higher Performances in Less Space

Field Installable Accessories and Trip Units



Dimensions 3P Fixed Version 8.07H x 5.51W x 4.07D

Compliance with Standards

UL 489

CSA C22.2 No.5.1

IEC 60947-2

Standards

EC directive:

- "Low Voltage Directives" (LVD) no. 73/23 EEC

- "Electromagnetic Compatibility Directive" (EMC) no.89/336 EEC

The ABB Quality System complies with the international ISO 9001 - 2000 Standard (model for quality assurance in design, development, construction, and installation and service) and with the equivalent European EN ISO 9001 and Italian UNI EN ISO 9001 Standards

Interrupting ratings (RMS sym. kAmps)

T5

Continuous Current Rating

400-600A

Number of Poles

3-4

		N	S	H	L	V
AC						
240V		65	100	150	200	200
480V		25	35	65	100	150
600V		18	25	35	65	100
DC* (400 A only)						
500V	2 poles in series	25	35	50	65	100
600V	3 poles in series	16	25	35	50	65

*Thermo Magnetic Trip Only



Company Quality Systems and Environmental Systems

The new Tmax series has a hologram on the front, obtained using special anti-imitation techniques, which guarantees the quality and that the circuit breaker is an original ABB product.

Attention to protection of the environment and to health and safety in the work place is another priority commitment for ABB and, as confirmation of this, the company environmental management system has been certified by RINA in 1997, in conformity with the international ISO 14001 Standard. This certification has been integrated in 1999 with the Management System for Health and Safety in the workplace, according to OHSAS 18001 (British Standards), obtaining one of the first certification of integrated management System, QES (Quality, Environment,

Safety) issued by RINA. ABB - the first industry in the electro-mechanical section in Italy to obtain this recognition - thanks to a revision of the production process with an eye to ecology has been able to reduce the consumption of raw materials and waste from processing by 20%. ABB's commitment to safeguarding the environment is also shown in a concrete way by the Life Cycle Assessments of its products carried out directly by the ABB Research and Development in collaboration with the ABB Research Center. Selection of materials, processes and packing materials is made optimizing the true environmental impact of the product, also foreseeing the possibility of its being recycled.

Mounting

Fixed
Plug-in
Drawout

Connections

Busbar connection or compression lugs
Pressure-type terminals for bare cables
Rear connections

Trip Unit

TMA thermo magnetic trip units, with adjustable thermal threshold ($I_1 = 0.7 \dots 1 \times I_n$) and adjustable magnetic threshold ($I_3 = 5 \dots 10 \times I_n$).

PR221DS, PR222DS/P and PR222DS/PD-A electronic trip unit

Weight (lbs)	8.55
---------------------	------

Auxiliary Devices for Indication and Control

- Auxiliary contacts - AUX
- Undervoltage release - UVR
- Shunt trip - SOR
- Terminal covers
- Front for lever operating mechanism - FLD
- Direct rotary handle - RHD
- Stored energy motor operator - MOE
- Key lock - KLF
- Early auxiliary contact - AUE
- Transmitted rotary handle - RHE
- Front terminal for copper cable - FC Cu
- Front extended terminal - EF
- Front terminal for copper-aluminum - FC CuAl
- Front extended spread terminal - ES
- Distribution lugs
- Rear orientated terminal - R
- Phase separators
- Residual current release (IEC Only)



ABB Inc.

1206 Hatton Road
Wichita Falls, TX 76302
For more information and
the location of your local
field office please go to
www.abb-control.com

Tmax-Molded Case Circuit Breakers

T6 800A Frame

AC Circuit Breakers and Switches

DC Circuit Breakers and Switches

3 and 4 Pole

Motor Circuit Protectors

Higher Performances in Less Space

Field Installable Accessories and Trip Units



Dimensions 3P Fixed Version 10.55H x 8.26W x 4.07D

Weight 20.9 (lbs)

Compliance with Standards

UL 489

CSA C22.2 No.5.1

IEC 60947-2

Standards

EC directive:

– “Low Voltage Directives” (LVD) no. 73/23 EEC

– “Electromagnetic Compatibility Directive” (EMC) no.89/336 EEC

The ABB Quality System complies with the international ISO 9001 - 2000 Standard (model for quality assurance in design, development, construction, and installation and service) and with the equivalent European EN ISO 9001 and Italian UNI EN ISO 9001 Standards

Interrupting ratings (RMS sym. kAmps)

		T6			
Continuous Current Rating		800			
Number of Poles		3-4			
		N	S	H	L
AC					
240V		65	100	200	200
480V		35	50	65	100
600V		20	25	35	42
DC*					
500V	2 poles in series	35	35	50	65
600V	3 poles in series	20	20	35	50

*Thermal Magnetic Trip Only



Company Quality Systems and Environmental Systems

The new Tmax series has a hologram on the front, obtained using special anti-imitation techniques, which guarantees the quality and that the circuit breaker is an original ABB product.

Attention to protection of the environment and to health and safety in the work place is another priority commitment for ABB and, as confirmation of this, the company environmental management system has been certified by RINA in 1997, in conformity with the international ISO 14001 Standard. This certification has been integrated in 1999 with the Management System for Health and Safety in the workplace, according to OHSAS 18001 (British Standards), obtaining one of the first certification of integrated management System, QES (Quality, Environment,

Safety) issued by RINA. ABB - the first industry in the electro-mechanical section in Italy to obtain this recognition - thanks to a revision of the production process with an eye to ecology has been able to reduce the consumption of raw materials and waste from processing by 20%. ABB's commitment to safeguarding the environment is also shown in a concrete way by the Life Cycle Assessments of its products carried out directly by the ABB Research and Development in collaboration with the ABB Research Center. Selection of materials, processes and packing materials is made optimizing the true environmental impact of the product, also foreseeing the possibility of its being recycled.

Mounting

Fixed
Drawout

Connections

Busbar connection or compression lugs
Pressure-type terminals for bare cables
Rear connections

Trip Unit

TMA thermal magnetic trip units, with adjustable thermal threshold ($I_1 = 0.7 \dots 1 \times I_n$) and adjustable magnetic threshold ($I_3 = 5 \dots 10 \times I_n$).

PR221DS, PR222DS/P, and PR222DS/PD-A electronic trip unit

Auxiliary Devices for Indication and Control

- Auxiliary contacts - AUX
- Undervoltage release - UVR
- Shunt trip - SOR
- Terminal covers
- Front for lever operating mechanism - FLD
- Direct rotary handle - RHD
- Stored energy motor operator - MOE
- Key lock - KLF
- Early auxiliary contact - AUE
- Transmitted rotary handle - RHE
- Front extended terminal - EF
- Front terminal for copper-aluminum - FC CuAl
- Front extended spread terminal - ES
- Rear orientated terminal - R
- Phase separators
- Residual current relay (IEC Only)



ABB Inc.

1206 Hatton Road
Wichita Falls, TX 76302
For more information and
the location of your local
field office please go to
www.abb-control.com

Tmax-Molded Case Circuit Breakers

T7 1200A Frame

AC Circuit Breakers and Switches

3 and 4 Pole

Motor Circuit Protectors

Higher Performances in Less Space

Field Installable Accessories and Trip Units



Dimensions 3P Fixed Version 10.55H x 8.26W x 6.06D

Weight 21.4 (lbs)

Compliance with Standards

UL 489

CSA C22.2 No.5.1

IEC 60947-2

Standards

EC directive:

– “Low Voltage Directives” (LVD) no. 73/23 EEC

– “Electromagnetic Compatibility Directive” (EMC) no.89/336 EEC

The ABB Quality System complies with the international ISO 9001 - 2000 Standard (model for quality assurance in design, development, construction, and installation and service) and with the equivalent European EN ISO 9001 and Italian UNI EN ISO 9001 Standards

Interrupting ratings (RMS sym. kAmps)		T7		
Continuous Current Rating		1200		
Number of Poles		3-4		
		S	H	L
AC				
	240V	65	100	150
	480V	50	65	100
	600V	25	50	65



Company Quality Systems and Environmental Systems

The new Tmax series has a hologram on the front, obtained using special anti-imitation techniques, which guarantees the quality and that the circuit breaker is an original ABB product.

Attention to protection of the environment and to health and safety in the work place is another priority commitment for ABB and, as confirmation of this, the company environmental management system has been certified by RINA in 1997, in conformity with the international ISO 14001 Standard. This certification has been integrated in 1999 with the Management System for Health and Safety in the workplace, according to OHSAS 18001 (British Standards), obtaining one of the first certification of integrated management System, QES (Quality, Environment,

Safety) issued by RINA. ABB - the first industry in the electro-mechanical section in Italy to obtain this recognition - thanks to a revision of the production process with an eye to ecology has been able to reduce the consumption of raw materials and waste from processing by 20%. ABB's commitment to safeguarding the environment is also shown in a concrete way by the Life Cycle Assessments of its products carried out directly by the ABB Research and Development in collaboration with the ABB Research Center. Selection of materials, processes and packing materials is made optimizing the true environmental impact of the product, also foreseeing the possibility of its being recycled.

Mounting

Fixed
Drawout

Connections

Busbar connection or compression lugs
Pressure-type terminals for bare cables
Rear connections

Trip Unit

PR231/P, PR232/P, PR331DS, and PR332DS/P electronic trip unit

Auxiliary Devices for Indication and Control

- Auxiliary contacts - AUX
- Undervoltage release - UVR
- Shunt trip - SOR
- Terminal covers
- Padlock provision - PLL
- Direct rotary handle - RHD
- Key lock - KLF
- Early auxiliary contact - AUE
- Transmitted rotary handle - RHE
- Front extended terminal - EF
- Front terminal for copper-aluminum - FC CuAl
- Front extended spread terminal - ES
- Rear orientated terminal - R
- Phase separators
- Residual current relay (IEC Only)



ABB Inc.

1206 Hatton Road
Wichita Falls, TX 76302
For more information and
the location of your local
field office please go to
www.abb-control.com

Digital Linear Chargers

Specifications

- Waterproof, shock-and vibration-resistant aluminum construction
- Saltwater tested and fully corrosion-resistant
- Short circuit, reverse polarity, and ignition protected
- For use with 12V/6 cell batteries that are flooded/wet cell, maintenance free or starved electrolyte (AGM) only
- FCC compliant
- UL listed to marine standard 1236
- 3 year warranty
- Replaces all existing current on-board chargers (excluding portables)
- No Price Increase
- Availability: November 2010



DIGITAL LINEAR ON-BOARD CHARGERS

PRODUCT CODE	PRODUCT DESCRIPTION
1821065	MK 106D (1 bank x 6 amps)
1821105	MK-110D (1 bank x 10 amps)
1822105	MK-210D (2 bank x 5 amps)
1823155	MK-315D (3 bank x 5 amps)
1822205	MK-220D (2 bank x 10 amps)
1823305	MK-330D (3 bank x 10 amps)
1824405	MK-440D (4 bank x 10 amps)
1822305	MK-230D (2 bank x 15 amps)
1823455	MK-345D (3 bank x 15 amps)
1824605	MK-460D (4 bank x 15 amps)

Digital Linear Chargers

Specifications (cont.)

- New 4-color package design

minnkotamotors.com

MINN-KOTA

ON-BOARD MARINE BATTERY CHARGER

DIGITALLY CONTROLLED 2X FASTER CHARGING PROTECTS BATTERIES

Digital CONTROL

MK210D

MK 210D
2 CHARGING BANKS
5 AMPS PER BANK
10 AMPS TOTAL OUTPUT

UL LISTED FC 10AMPS

CHARGING TECHNOLOGY

CHARGING TECHNOLOGY

DIGITALLY CONTROLLED.
Microprocessor design protects your batteries so you can stay on the water longer. It monitors temperature and state of charge to create a faster, regulated, more precise charge. Also includes automatic shut-off when charging is complete to extend battery life.

DIGITALLY CONTROLLED.
Microprocessor design protects your batteries so you can stay on the water longer. It monitors temperature and state of charge to create a faster, regulated, more precise charge. Also includes automatic shut-off when charging is complete to extend battery life.

ENHANCED STATUS CODES.
Provides comprehensive feedback on charge stage, maintenance mode status, error notification and full charge.

ENHANCED STATUS CODES.
Provides comprehensive feedback on charge stage, maintenance mode status, error notification and full charge.

Digital CONTROL

MULTI-STAGE CHARGING.
Delivers a fast, precise charge profile by automatically controlling current and voltage without overcharging your batteries.

MULTI-STAGE CHARGING.
Delivers a fast, precise charge profile by automatically controlling current and voltage without overcharging your batteries.

AUTOMATIC TEMPERATURE COMPENSATION.
Adjusts output voltage based on ambient temperature to ensure a full charge and protect your batteries.

AUTOMATIC TEMPERATURE COMPENSATION.
Adjusts output voltage based on ambient temperature to ensure a full charge and protect your batteries.

MULTI-STAGE CHARGING
BULK ABSORPTION MAINTENANCE
AMPS & VOLTS
TIME (THREE STAGE CHARGER)
■ VOLTS
■ AMPS

BATTERY CHARGER TEMPERATURE COMPENSATION
absorption voltage (output voltage)
BATTERY VOLTAGE
BATTERY TEMPERATURE (degrees F)

2010



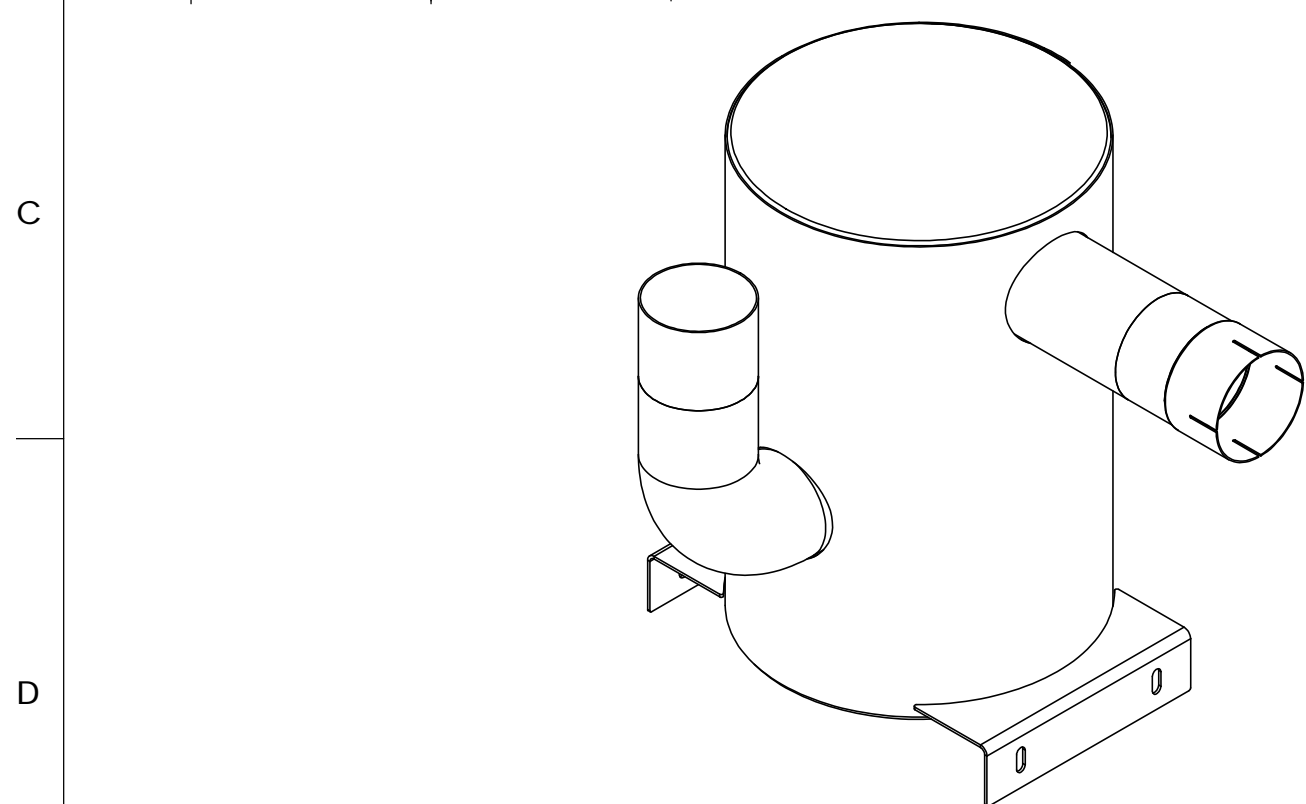
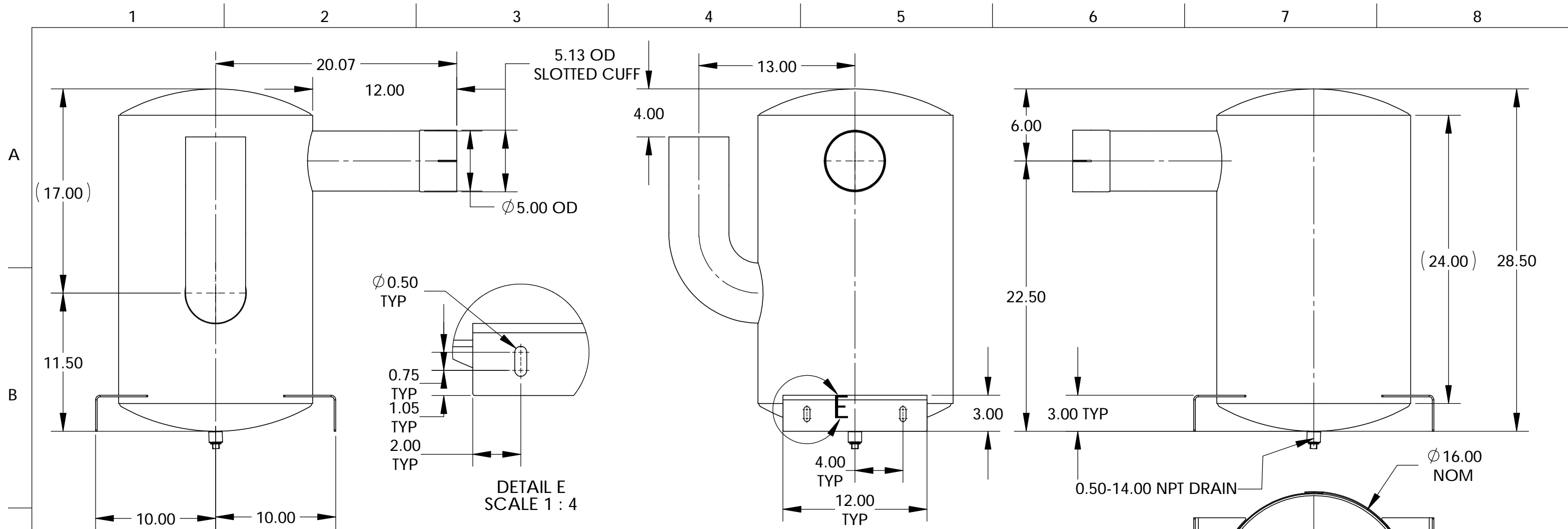

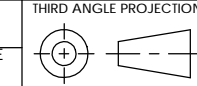
ENGINE INFORMATION	SILENCER INFORMATION	DRAWN BY	DATE	
ENGINE MAKE MTU	RESONATOR FREQUENCY ---	CB	08/23/2017	
ENGINE MODEL 6R1600	RESONATOR ALPHA ---	CHECKED BY CB	DATE 09/15/2017	DESCRIPTION SIL: COMP CRIT CS S-E 5.00-5.00 Ø16.00 28.50 OAL F:6.00 --- CONSTRUCTION MATERIAL CS
DISPLACEMENT 641	SILENCER Km ---	ENGINEERING CB	DATE 09/15/2017	
EXHAUST FLOW 2542	SILENCER IL ---	MANUFACTURING CB	WEIGHT (LBS) 78	FINISH HIGH TEMP BLACK PAINT
EXHAUST TEMPERATURE 806	TOLERANCES DO NOT APPLY TO GAGE THICKNESS OR COMMERCIAL FEATURES	TOLERANCES UNLESS OTHERWISE SPECIFIED X = ±0.25 ALL ANGLES .XX = ±0.125 ±1° .XXX = ±0.0625 .XXXX = ±0.03125	SHEET 3 OF 3	
MAX BACK PRESSURE 60.2	THIRD ANGLE PROJECTION	This drawing and the information contained is confidential and the property of Bergari Solutions, LLC. None of this information is to be copied or shared in any form without the express permission from Bergari Solutions, LLC.		PART NUMBER 500-008546
RAW SOUND PRESSURE ---		SCALE (DO NOT SCALE)	SHEET SIZE	REV 01

REV.	BY	DATE	DESCRIPTION	ECO
01	CB	09/15/2017	EXTENDED OVERALL LENGTH	---

CUSTOMER P7/N

D

C

B

A

SP-2650 OPEN DIMENSIONAL OVERVIEW

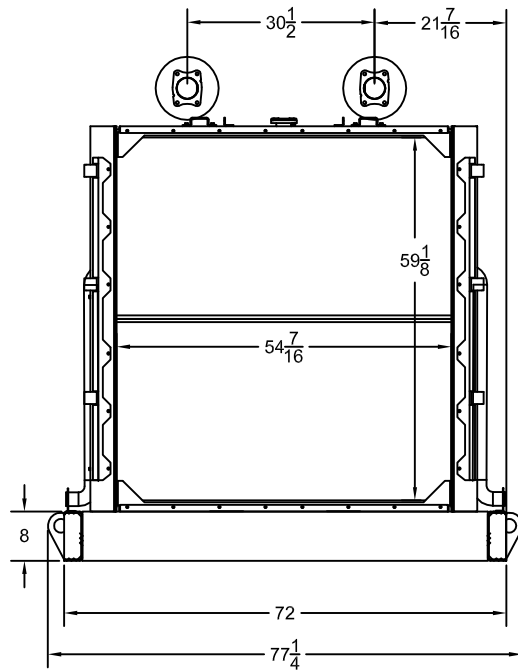
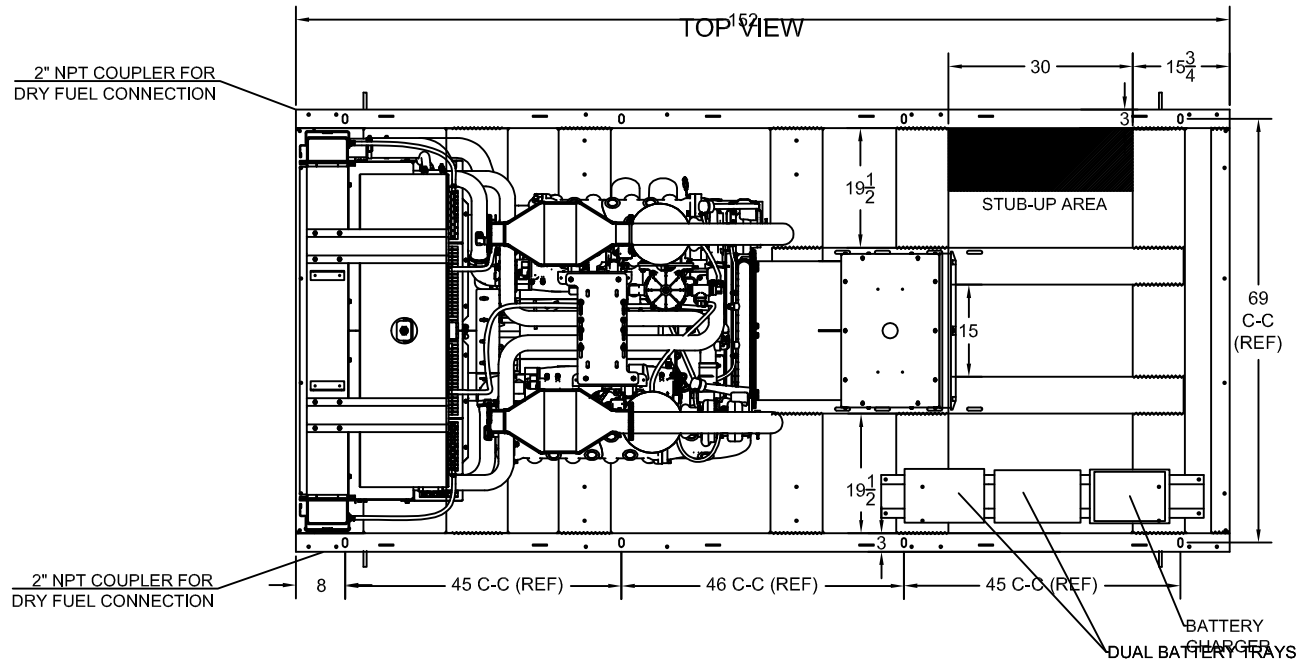

RADIATOR VIEW

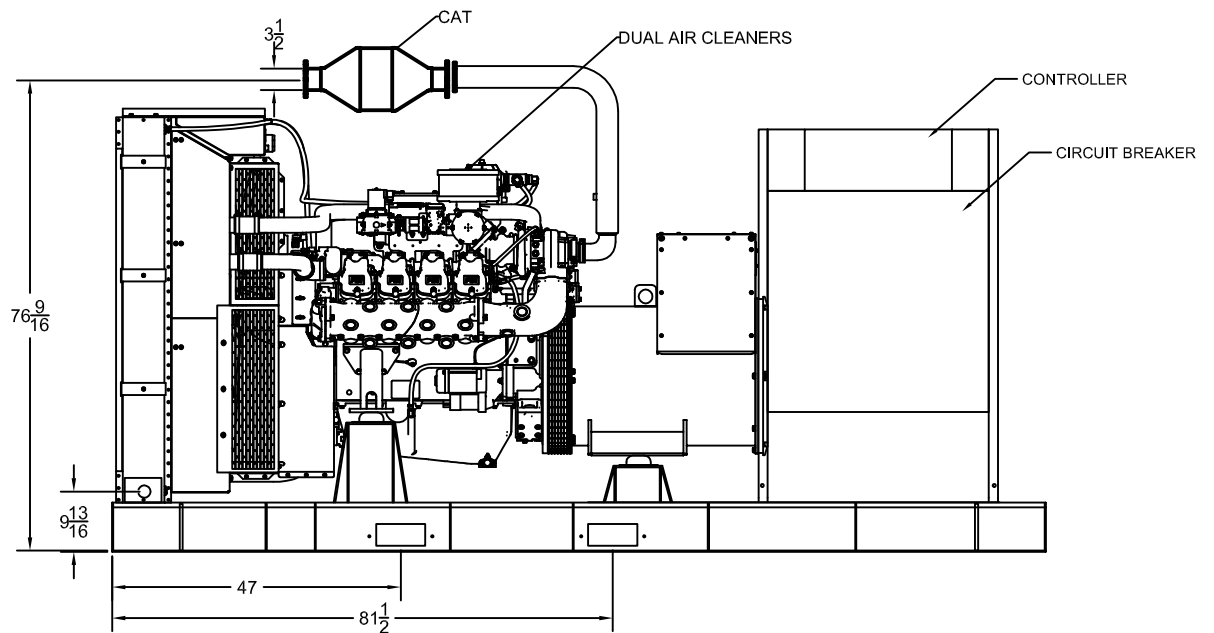

SIDE VIEW

LEVEL 2 ENCLOSURE OUTLINE DIMENSIONS FOR SP-2000, THRU SP-3000 & SPMD-3500 THRU SPMD-5000

TOP VIEW

(GEN-SET HAS (6) DOORS, (3) SHOWN OPEN ARE TYPICAL FOR BOTH SIDES)

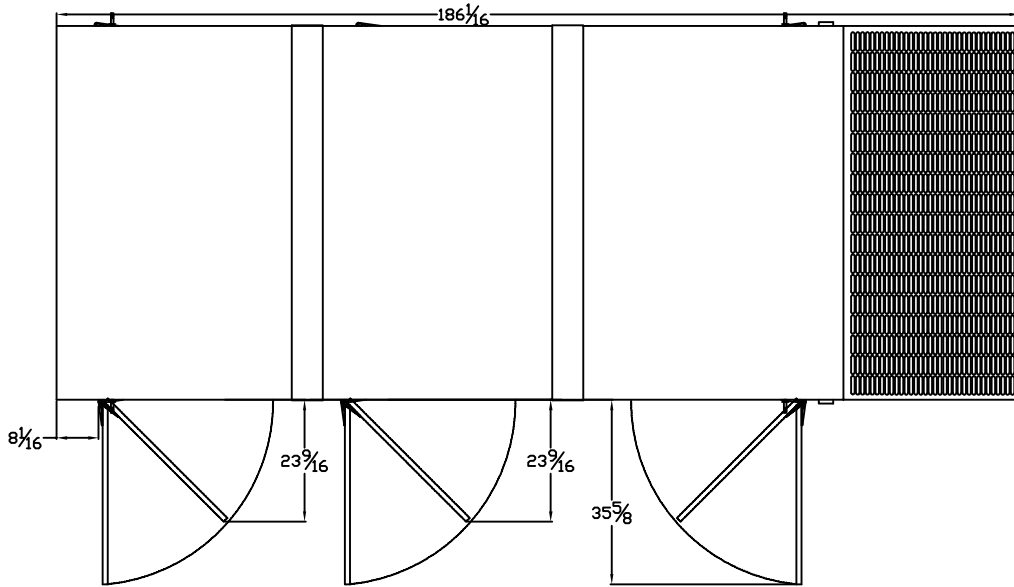

FRAME VIEW

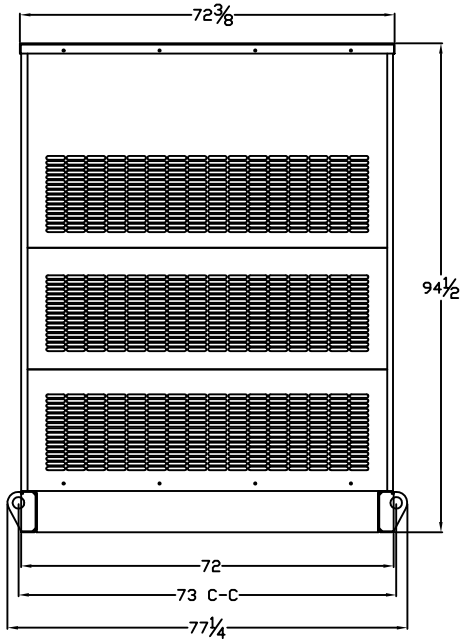
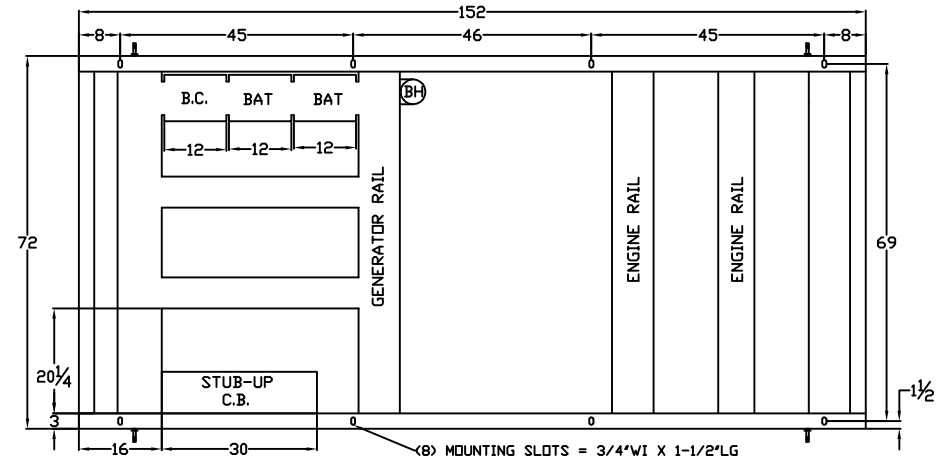

GENERATOR END VIEW

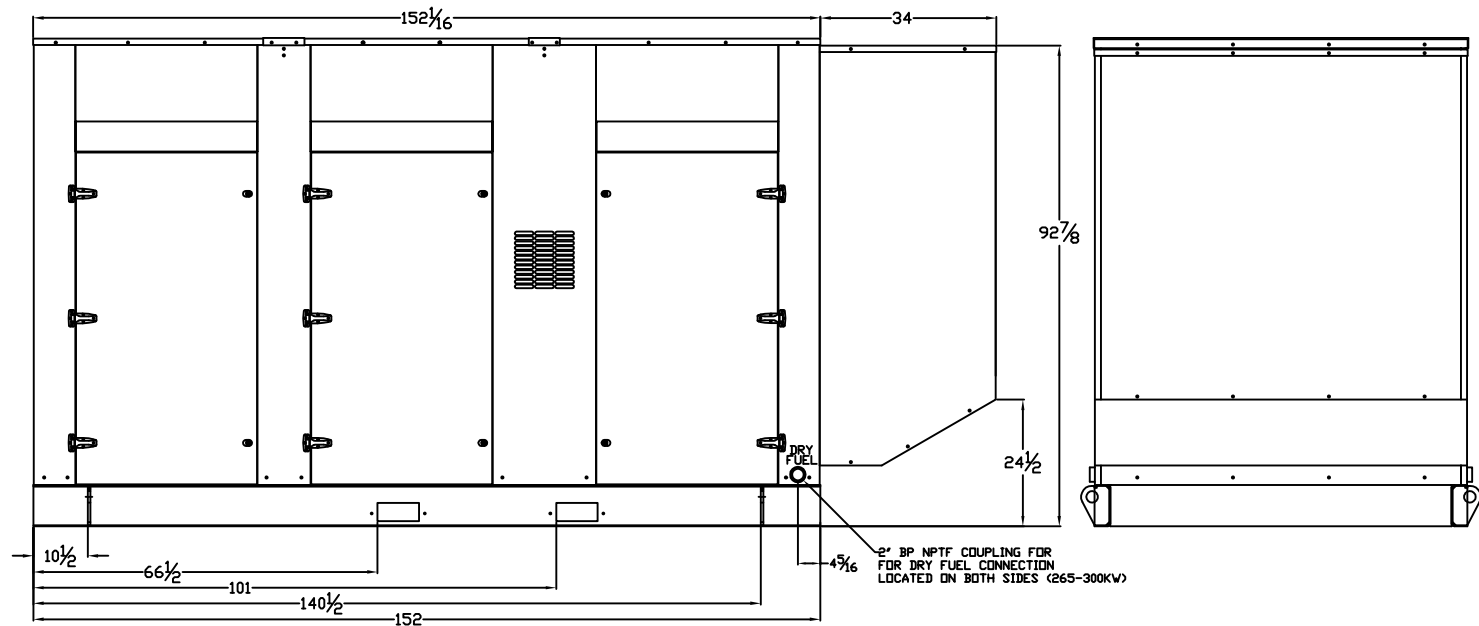

SIDE VIEW

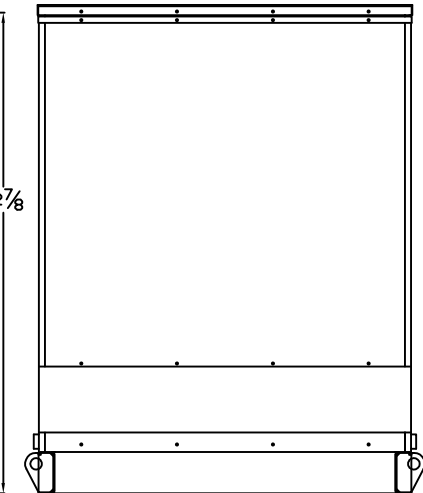

RADIATOR END VIEW