



GILLETTE GENERATORS

60 HZ MODEL
SP-620

LIQUID COOLED LPG/NG ENGINE GENERATOR SET

Model	STANDBY 120°C RISE		
	HZ	LPG	N.G.
SP-620-60 HERTZ	60	60/62	58/60



All generator sets are USA prototype built and thoroughly tested. Production models are USA factory built and 100% load tested.



UL2200, UL1446, UL508, UL142, UL498



NFPA 110, 99, 70, 37

All generator sets meet NFPA-110 Level 1, when equipped with the necessary accessories and installed per NFPA standards.



NEC 700, 701, 702, 708



NEMA ICS10, MG1, ICS6, AB1



ANSI C62.41, 27, 59, 32, 480, 40Q, 81U, 360-05



ASCE 7-05 & 7-10

All generator sets meet 180 MPH rating.



EPA 40CFR Part 60, 1048, 1054, 1065, 1068

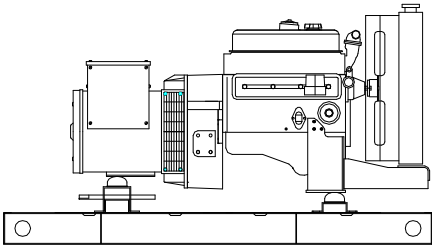

“OPEN” GEN-SET

There is no enclosure, so gen-set must be placed within a weather protected area, un-inhabited by humans or animals, with proper ventilation. Silencer not supplied, as installation requirements are not known. However, this item is available as optional equipment.

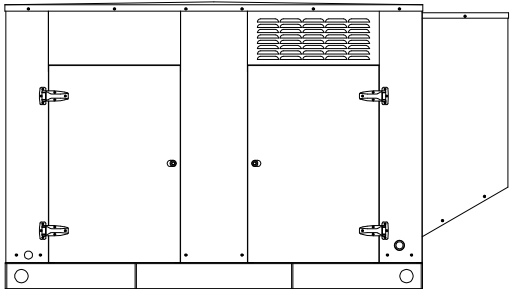

“LEVEL 2” HOUSED GEN-SET

Full aluminum weather protection and superior sound attenuation for specific low noise applications. Critical grade muffler is standard.

GENERATOR RATINGS

GENERATOR MODEL	VOLTAGE		PH	HZ	LIQUID PROPANE GAS FUEL		NATURAL GAS FUEL	
	L-N	L-L			120°C RISE STANDBY RATING		120°C RISE STANDBY RATING	
					KW/KVA	AMP	KW/KVA	AMP
SP-620-1-1	120	240	1	60	60/60	250	58/58	242
SP-620-3-2	120	208	3	60	62/77.5	215	60/75	208
SP-620-3-3	120	240	3	60	62/77.5	187	60/75	181
SP-620-3-4	277	480	3	60	62/77.5	93	60/75	90
SP-620-3-5	127	220	3	60	62/77.5	204	60/75	197
SP-620-3-16	346	600	3	60	62/77.5	74	60/75	72

RATINGS: All single phase gen-sets are dedicated 4 lead windings, rated at unity (1.0) power factor. All three phase gen-sets are 12 lead windings, rated at .8 power factor. 120°C “STANDBY RATINGS” are strictly for gen-sets that are used for back-up emergency power to a failed normal utility power source. This standby rating allows varying loads, with no overload capability, for the entire duration of utility power outage. All gen-set power ratings are based on temperature rise measured by resistance method as defined by MIL-STD 705C and IEEE STD 115, METHOD 6.4.4. All generators have class H (180°C) insulation system on both rotor and stator windings. All factory tests and KW/KVA charts shown above are based on 120°C (standby) R/R winding temperature, within a maximum 40°C ambient condition. Generators operated at standby power ratings must not exceed the temperature rise limitation for class H insulation system, as specified in NEMA MG1-22.40. Specifications & ratings are subject to change without prior notice.

APPLICATION AND ENGINEERING DATA FOR MODEL SP-620-60 HZ

GENERATOR SPECIFICATIONS

Manufacturer.....Stamford Electric Generators
 Model & Type.....UCI224F-06, 4 Pole, 4 Lead, Single Phase
 UCI224F-311, 4 Pole, 12 Lead re-connectable, Three Phase
 UCI224F-17, 4 Pole, 6 Lead, 600V, Three Phase,
 Exciter.....Brushless, shunt excited
 Voltage Regulator.....Solid State, HZ/Volts
 Voltage Regulation.....½%, No load to full load
 Frequency.....Field convertible, 60 HZ to 50 HZ
 Frequency Regulation.....½% (½ cycle, no load to full load)
 Unbalanced Load Capability.....100% of standby amps
 Total Stator and Load Insulation.....Class H, 180°C
 Temperature Rise.....130°C R/R, standby rating @ 40°C amb.
 1 Ø Motor Starting @ 30% Voltage Dip (240V).....168 kVA
 3 Ø Motor Starting @ 30% Voltage Dip (208-240V).....190 kVA
 3 Ø Motor Starting @ 30% Voltage Dip (480V).....260 kVA
 3 Ø Motor Starting @ 30% Voltage Dip (600V).....290 kVA
 Bearing.....1, Pre-lubed and sealed
 Coupling.....Direct flexible disc
 Total Harmonic Distortion.....Max 3½% (MIL-STD705B)
 Telephone Interference Factor.....Max 50 (NEMA MG1-22)
 Deviation Factor.....Max 5% (MIL-STD 405B)
 Ltd. Warranty Period.....24 Months from date of start-up or
1000 hours use, first to occur.

GENERATOR FEATURES

- World Renown Stamford Electric Generator having UL-1446 certification.
- Full generator protection with **Deep Sea 7420** controller, having UL-508 certification.
- Automatic voltage regulator with over-excitation, under-frequency compensation, under-speed protection, and EMI filtering. Entire solid-state board is encapsulated for moisture protection.
- Generator power ratings are based on temperature rise, measured by resistance method, as defined in MIL-STD 705C and IEEE STD 115, Method 6.4.4.
- Power ratings will not exceed temperature rise limitation for class H insulation as per NEMA MG1-22.40.
- Insulation resistance to ground, exceeds 1.5 meg-ohm.
- Stator receives 2000 V. hi-potential test on main windings, and rotor windings receive a 1500 V. hi-potential test, as per MIL-STD 705B.
- Full amortisseur windings with UL-1446 certification.
- Complete engine-generator torsional acceptance, confirmed during initial prototype testing.
- Full load testing on all engine-generator sets, before shipping.
- Self ventilating and drip-proof & revolving field design

ENGINE SPECIFICATIONS AND APPLICATIONS DATA

ENGINE

Manufacturer.....General Motors
 Model and Type.....Ind. Power Train, Vortec, 5.7L, 4 cycle
 Aspiration.....Natural
 Cylinder Arrangement.....8 Cylinders, V-8
 Displacement Cu. In. (Liters).....350 (5.7)
 Bore & Stroke In. (Cm.).....4 x 3.48 (10.2 x 8.84)
 Compression Ratio.....9.1:1
 Main Bearings & Style.....5M 400 Copper Lead
 Cylinder Head.....Cast Iron
 Pistons.....High, Silicon Aluminum
 Crankshaft.....Nodular Iron
 Exhaust Valve.....Forged Steel
 Governor.....Electronic
 Frequency Reg. (no load-full load).....Isochronous
 Frequency Reg. (steady state).....± 1/4%
 Air Cleaner.....Dry, Replaceable Cartridge
 Engine Speed.....1800 rpm
 Piston Speed, ft/min (m./min).....1044 (318)
 Max Power, bhp (kwm) Standby /LPG.....108 (81)
 Max Power, bhp (kwm) Standby/NG.....100 (75)
 Ltd. Warranty Period.....12 Months or 2000 hrs., first to occur

FUEL SYSTEM

Type.....LPG or NAT. GAS, Vapor Withdrawal
 Fuel Pressure (kpa), in. H₂O*.....(1.74-2.74), 7"-11"
 Secondary Fuel Regulator.....NG or LPG Vapor System
 Auto Fuel Lock-Off Solenoid.....Standard on all sets
 Fuel Supply Inlet Line.....1" NPTF
 * Measured at gen-set fuel inlet, downstream of any dry fuel accessories.

FUEL CONSUMPTION

LP GAS: FT ³ /HR (M ³ /HR)	STANDBY
100% LOAD	330 (9.3)
75% LOAD	240 (7.0)
50% LOAD	195 (5.5)
LPG = 2500 BTU X FT³/HR = Total BTU/HR	
LPG Conversion: 8.50 FT³ = 1 LB. : 36.4 FT³ = 1 GAL.	

NAT. GAS: FT ³ /HR (M ³ /HR)	STANDBY
100% LOAD	800 (22.6)
75% LOAD	695 (20.0)
50% LOAD	500 (14.2)
NG = 1000 BTU X FT³/HR = Total BTU/HR	

OIL SYSTEM

Type.....Full Pressure
 Oil Pan Capacity qt. (L).....5.0 (4.7)
 Oil Pan Cap. W/ filter qt. (L).....6.5 (6.2)
 Oil Filter.....1, Replaceable Spin-On

ELECTRICAL SYSTEM

Ignition System.....Electronic
 Eng. Alternator and Starter:
 Ground.....Negative
 Volts DC.....12
 Max. Amp Output of Alternator.....70
 Recommended Battery to -18°C (0°F):..12 VDC, Size BCI# 24F
 Max Dimensions: ..10 3/4" lg X 6 3/4" wi X 9" hi, with standard round posts. Min. output at 600 CCA. Battery tray (max. dim. at 12"lg x 7"wi), hold down straps, battery cables, and battery charger, is furnished. Installation of (1) starting battery is required, with possible higher AMP/HR rating, as described above, if normal environment averages -13°F (-25°C) or cooler.

APPLICATION AND ENGINEERING DATA FOR MODEL SP-620-60 HZ

COOLING SYSTEM

Type of System Pressurized, closed recovery
 Coolant PumpPre-lubricated, self-sealing
 Cooling Fan Type (no. of blades) Pusher (10)
 Fan Diameter inches (cm)..... 21" (533)
 Ambient Capacity of Radiator °F (°C)..... 125 (51.6)
 Engine Jacket Coolant Capacity Gal (L)..... 1.8 (6.8)
 Radiator Coolant Capacity Gal. (L) 5.2 (19.7)
 Maximum Restriction of Cooling Air Intake
 and discharge side of radiator in. H₂O (kpa)..... .5 (.125)
 Water Pump Capacity gpm (L/min)..... 27 (100)
 Heat Reject Coolant: Btu/min (kw) 3200 (54.9)
 Low Radiator Coolant Level Shutdown.....Standard
 Note: Coolant temp. shut-down switch setting at 212°F (100°C) with 50/50
 (water/antifreeze) mix.

COOLING AIR REQUIREMENTS

Combustion Air, cfm (m³/min)185 (5.2)
 Radiator Air Flow cfm (m³/min)6000 (170)
 Heat Rejected to Ambient:
 Engine: kw (btu/min)30.9 (1760)
 Alternator: kw (btu/min).....7.5 (430)

EXHAUST SYSTEM

Exhaust Outlet Size.....2.5"
 Max. Back Pressure in. hg (KPA).....3.0 (10.2)
 Exhaust Flow, at rated kw: cfm (m³/min)580 (16.5)
 Exhaust Temp., at rated kw: °F (°C) 1200 (649)
 Engines are EPA certified for LPG and Natural Gas.

SOUND LEVELS MEASURED IN dB(A)

	Open Set	Level 2 Encl.
Level 2, Critical Silencer	74.....	67
Level 3, Hospital Silencer.....		62

Note: Open sets (no enclosure) have silencer system choices due to unknown job-site applications. Level 2 enclosure has installed critical silencer with upgrade to Level 3 hospital silencer. Sound tests are averaged from several test points and taken at 23 ft. (7 m) from source of noise at normal operation.

DERATE GENERATOR FOR ALTITUDE

3% per 1000 ft. (305m) above 3000 ft.(914m) from sea level

DERATE GENERATOR FOR TEMPERATURE

2% per 10°F (5.6°C) above 104°F (40°C)

DIMENSIONS AND WEIGHTS

	Open Set	Level 2 Enclosure
Length in (cm).....	78 (199)	94 (238)
Width in (cm).....	42 (107)	42 (107)
Height in (cm).....	38 (97)	53 (134)
1 Ø Net Weight lbs (kg).....	1931 (876)	2456 (1114)
1 Ø Ship Weight lbs (kg).....	2031 (921)	2556 (1159)
3 Ø Net Weight lbs (kg).....	1891 (858)	2416 (1096)
3 Ø Ship Weight lbs (kg).....	1991 (903)	2516 (1141)

DEEP SEA 7420 DIGITAL MICROPROCESSOR CONTROLLER



Deep Sea 7420

The “7420” controller is an auto start mains (utility) failure module for single gen-set applications. This controller includes a backlit LCD display which continuously displays the status of the engine and generator at all times.

The “7420” controller will also monitor speed, frequency, voltage, current, oil pressure, coolant temp., and fuel levels. These modules have been designed to display warning and shut down status. It also includes: (11) configurable inputs • (8) configurable outputs • voltage monitoring • mains (utility) failure detection • (250) event logs • configurable timers • automatic shutdown or warning during fault detection • remote start (on load) • engine preheat • advanced metering capability • hour meter • text LCD displays • protected solid state outputs • test buttons for: stop/reset • manual mode • auto mode • lamp test • start button • power monitoring (kWh, kVAr, kVAh, kVArh)

This controller includes expansion features including RS232, RS484 (using MODBUS-RTU/TCP), direct USB connection with PC, expansion optioned using DSENet for remote annunciation and remote relay interfacing for a distance of up to 3300FT. The controller software is freely downloadable from the internet and allows monitoring with direct USB cable, LAN, or by internet via the built in web interface.



Further expansion is available by adding the optional “WebNet” gateway interface module. This device will allow comprehensive monitoring of the generator via the cloud including identification, location, and status. Some advantages of this module include: reduced site visits and maintenance costs • remote fuel management • fault analysis • asset tracking • automatic system alerts • maximized system up-time.

STANDARD FEATURES FOR MODEL SP-620-60HZ

STANDARD FEATURES

CONTROL PANEL:

- Deep Sea 7420 digital microprocessor with logic allows programming in the field. Controller has:
- STOP-MANUAL-AUTO modes and automatic engine shutdowns, signaled by full text LCD indicators:
 - Low oil pressure
 - High engine temp
 - Low Radiator Level
 - Three auxiliary alarms
 - Battery fail alarm
 - Engine fail to start
 - Engine over speed
 - Engine under speed
 - Over & under voltage
- Also included is tamper-proof engine hour meter

ENGINE:

- Full flow oil filter • Air filter • Oil pump • Solenoid type starter motor • Hi-temp radiator • Jacket water pump
- Thermostat • Pusher fan and guard • Exhaust manifold
 - 12 VDC battery charging alternator • Flexible exhaust connector • "Isochronous" duty, electronic governor • Secondary dry fuel regulator • Dry fuel lock-off solenoid • Vibration isolators • Closed coolant recovery system with 50/50 water to anti-freeze mixture

AC GENERATOR SYSTEM:

- AC generator • Shunt excited • Brushless design • Circuit Breaker installed and wired to gen-set • Direct connection to engine with flex disc • Class H, 180°C insulation • Self ventilated • Drip proof construction • UL Certified

VOLTAGE REGULATOR:

- ½% Voltage regulation • EMI filter • Under-speed protection • Over-excitation protection • total encapsulation

DC ELECTRICAL SYSTEM:

- Battery tray • Battery cables • Battery hold down straps
- 2-stage battery float charger with maintaining & recharging automatic charge stages

WEATHER/SOUND PROOF ALUMINUM HOUSING CORROSION RESISTANT PROTECTION CONSISTING OF:

- 9 Heated And Agitated Wash Stages
- Zinc Phosphate Etching-coating Stage
- Final Baked On Enamel Powder Coat
- 18/8 Stainless Steel Hardware

Design & specifications subject to change without prior notice. Dimensions shown are approximate. Contact Gillette for certified drawings.
DO NOT USE DIMENSIONS FOR INSTALLATION PURPOSES.

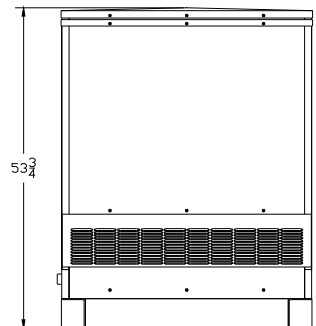
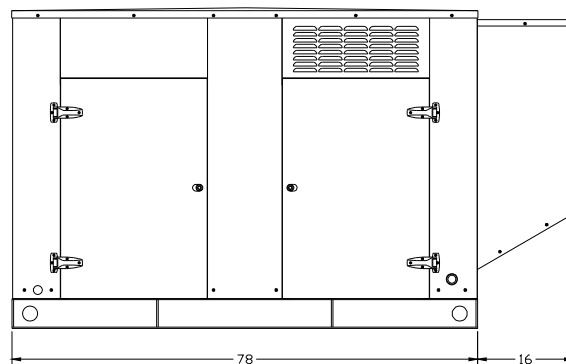
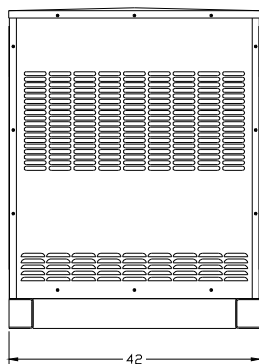
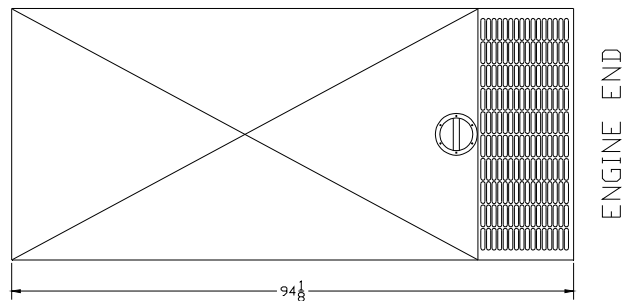

GM Industrial Engine Power by Power Solutions, Inc.



Feature/Benefits

- Designed to work with gasoline, liquid propane gas and natural gas.
- Nodular iron crankshaft has enlarged journal fillet radii for increased durability.
- World-class engine sealing system uses composite cylinder head gaskets with steel cores, a one-piece rear main crankshaft seal, a one-piece oil pan seal and moulded rocker cover seals.
- Hydraulic roller camshaft is optimized for maximum performance.
- Sintered powdered-metal exhaust valve seat inserts for enhanced durability.
- Exhaust valve rotators improve valve and valve seat durability.
- Positive inlet valve stem seals to control oil consumption.
- High Energy Ignition (HEI) distributor and coil and are standard.
- Common rear face on most GM industrial engines for easy hookup with housing.

Options

- Cast iron 4 barrel intake manifold is standard.
- An Electronic control Module (ECM) utilizing state-of-the-art hybrid technology and related hardware to optimize fuel and spark requirements is available
- Fuel options LPG, NG
- SAE 3 flywheel housing (cast iron)
- SAE flywheels
- Custom made flywheels for numerous applications
- Cooling fans
- Radiators
- Dry type industrial air cleaners (safety element air cleaners available)
- Electric governor systems available - High Output Camshaft

Power Solutions, Inc.

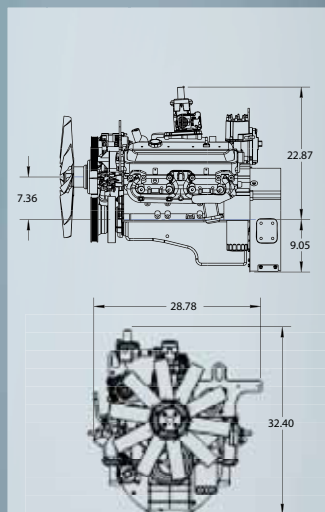

PSI Offers Turn-Key Certified and Non-Certified Engine Packages

Product Engineering Data

5.7L ENGINE

General Data

Type: 90 5.7L V8
Displacement: 350 cid (5736.50 cc)
Compression Ratio: 9.4:1
Valve Configuration: Pushrod Actuated Overhead Valves
Manufactured: Toluca, Mexico
Valve Lifters: Hydraulic Roller
Bore X Stroke: 4.00 x 3.48 in (101.60 mm x 88.39 mm)
Main Bearing Caps: 2-Bolt
Balance Method: External
Intake Manifold: Carburetor or Mixer
Oil Pan Capacity: 5 qt
Fuel Types: LPG or NG
Engine Rotation: Clockwise (from the front)
Paint Protection: Component Painted
Horsepower: 201 hp @ 3000 rpm (Gasoline), 151 hp @ 3000 rpm (LP and natural gas)
Torque: 320 lb-ft @ 2500 rpm (Gasoline), 272 lb-ft @ 2500 rpm (LP and natural gas)
Shipping Weight: 582 lb (264 kg)

Materials

Block: Cast Iron
Cylinder Head: Cast Iron
Intake Manifold: Cast Aluminum
Main Bearing Caps: Cast Iron
Crankshaft: Nodular Iron
Camshaft: Cast Iron
Pistons: High Silicon Content Aluminum
Exhaust Seat: Sintered Powdered Metal Insert

Engine Sealing System

One-piece viton rear main seal
 One-piece oil pan gasket
 Composite graphite cylinder head gaskets with stainless steel core
 Non-asbestos gaskets throughout

Fuel System Options

Closed-Loop Fuel System Kit Dual Fuel

LPG (Mixer, Throttle Body, Fuel Lock, Regulator)

LPG W/Governor (Same As Above w/Elec. Governor)

LPG W/Governor (Same As Above w/Velocity Governor)

LPG Carb

NG/LPG Carb Dual Fuel

NG Carb

NG (Mixer, Throttle Body & Air Cleaner)

NG W/Governor (Same As Above w/Elec. Governor)

Three Way Catalyst Available

GASOLINE, FUEL INJECTION

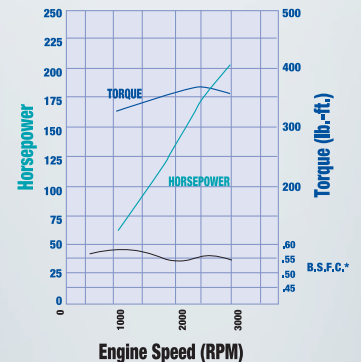

Power corrected to SAE J1995. Actual power levels may vary due to fuel system calibration, and design of induction and exhaust system

LP, CARBURETED

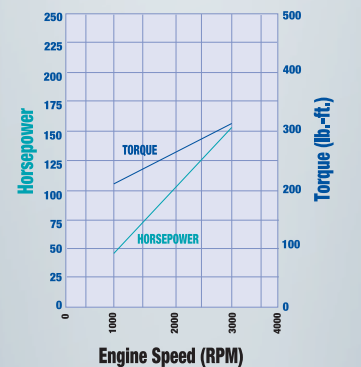

Power corrected to SAE J1995. Actual power levels may vary due to fuel system calibration, and design of induction and exhaust system

NATURAL GAS, CARBURETED

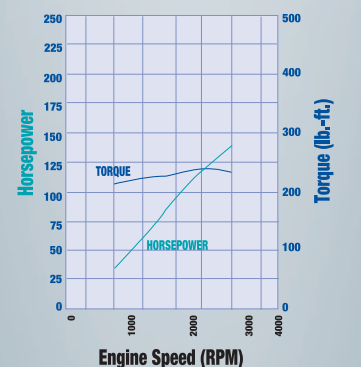

Power corrected to SAE J1995. Actual power levels may vary due to fuel system calibration, and design of induction and exhaust system



655 Wheat Lane, Wood Dale, IL 60191
 Telephone 630-350-9400
 Fax 630-350-9900
 www.psiengines.com



Information may vary with application. All specifications listed are based on the latest product information available at the time of publication. The right is reserved to make changes at any time without notice.

STAMFORD®

UCI224F - Winding 06

Technical Data Sheet

PDF

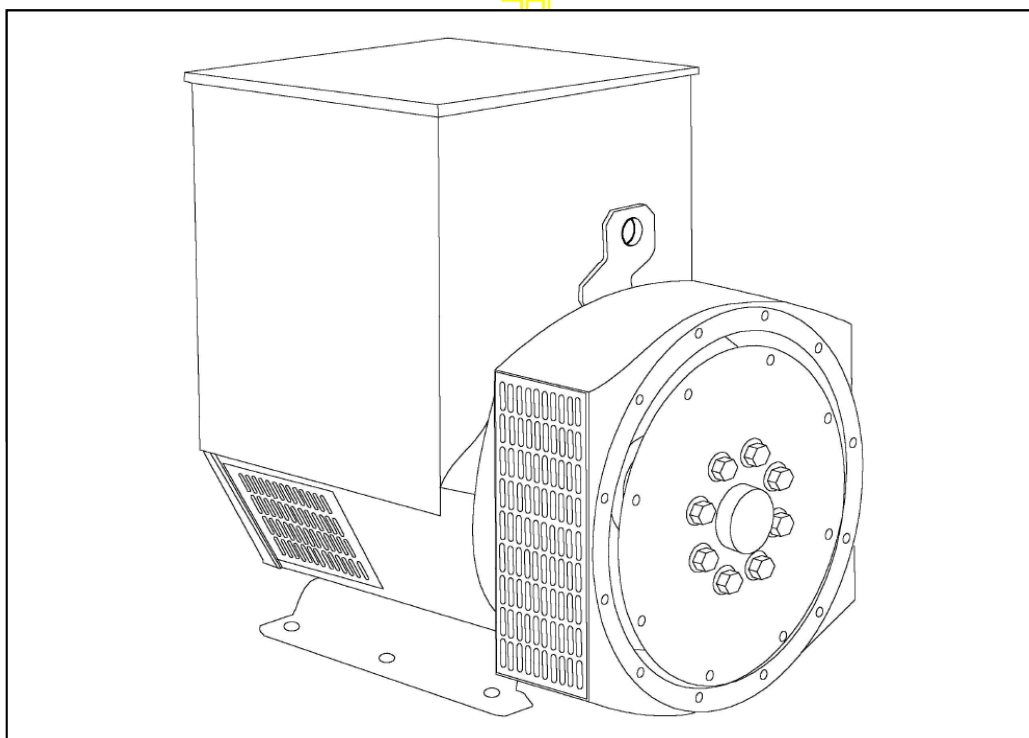

SPECIFICATIONS & OPTIONS

STANDARDS

Stamford industrial generators meet the requirements of BS EN 60034 and the relevant section of other international standards such as BS5000, VDE 0530, NEMA MG1-32, IEC34, CSA C22.2-100, AS1359.

Other standards and certifications can be considered on request.

VOLTAGE REGULATORS**SX460 AVR - STANDARD**

With this self excited control system the main stator supplies power via the Automatic Voltage Regulator (AVR) to the exciter stator. The high efficiency semiconductors of the AVR ensure positive build-up from initial low levels of residual voltage.

The exciter rotor output is fed to the main rotor through a three phase full wave bridge rectifier. This rectifier is protected by a surge suppressor against surges caused, for example, by short circuit.

AS440 AVR

With this self-excited system the main stator provides power via the AVR to the exciter stator. The high efficiency semi-conductors of the AVR ensure positive build-up from initial low levels of residual voltage.

The exciter rotor output is fed to the main rotor through a three-phase full-wave bridge rectifier. The rectifier is protected by a surge suppressor against surges caused, for example, by short circuit or out-of-phase paralleling.

The AS440 will support a range of electronic accessories, including a 'droop' Current Transformer (CT) to permit parallel operation with other ac generators.

MX341 AVR

This sophisticated AVR is incorporated into the Stamford Permanent Magnet Generator (PMG) control system.

The PMG provides power via the AVR to the main exciter, giving a source of constant excitation power independent of generator output. The main exciter output is then fed to the main rotor, through a full wave bridge, protected by a surge suppressor. The AVR has in-built protection against sustained over-excitation, caused by internal or external faults. This de-excites the machine after a minimum of 5 seconds.

An engine relief load acceptance feature can enable full load to be applied to the generator in a single step.

MX321 AVR

The most sophisticated of all our AVRs combines all the features of the MX341 with, additionally over voltage protection built-in and short circuit current level adjustments as an optional facility.

WINDINGS & ELECTRICAL PERFORMANCE

All generator stators are wound to 2/3 pitch. This eliminates triplen (3rd, 9th, 15th ...) harmonics on the voltage waveform and is found to be the optimum design for trouble-free supply of non-linear loads. The 2/3 pitch design avoids excessive neutral currents sometimes seen with higher winding pitches, when in parallel with the mains. A fully connected damper winding reduces oscillations during paralleling. This winding, with the 2/3 pitch and carefully selected pole and tooth designs, ensures very low waveform distortion.

TERMINALS & TERMINAL BOX

Dedicated Single Phase windings have 4 ends brought out to the terminals, which are mounted on a cover at the non-drive end of the generator. A sheet steel terminal box contains the AVR and provides ample space for the customers' wiring and gland arrangements. It has removable panels for easy access.

SHAFT & KEYS

All generator rotors are dynamically balanced to better than BS6861:Part 1 Grade 2.5 for minimum vibration in operation. Two bearing generators are balanced with a half key.

INSULATION/IMPREGNATION

The insulation system is class 'H'.

All wound components are impregnated with materials and processes designed specifically to provide the high build required for static windings and the high mechanical strength required for rotating components.

QUALITY ASSURANCE

Generators are manufactured using production procedures having a quality assurance level to BS EN ISO 9001.

The stated voltage regulation may not be maintained in the presence of certain radio transmitted signals. Any change in performance will fall within the limits of Criteria 'B' of EN 61000-6-2:2001. At no time will the steady-state voltage regulation exceed 2%.

DE RATES

All values tabulated on page 7 are subject to the following reductions

5% when air inlet filters are fitted.

3% for every 500 metres by which the operating altitude exceeds 1000 metres above mean sea level.

3% for every 5 C by which the operational ambient temperature exceeds 40 C.

Note: Requirement for operating in an ambient exceeding 60 C must be referred to the factory.

NB Continuous development of our products entitles us to change specification details without notice, therefore they must not be regarded as binding.

Front cover drawing typical of product range.

UCI224F

WINDING 06

CONTROL SYSTEM	SEPARATELY EXCITED BY P.M.G.		
A.V.R.	MX341	MX321	
VOLTAGE REGULATION	± 1%	± 0.5 %	With 4% ENGINE GOVERNING
SUSTAINED SHORT CIRCUIT	REFER TO SHORT CIRCUIT DECREMENT CURVES (page 6)		

CONTROL SYSTEM	SELF EXCITED		
A.V.R.	SX460	AS440	
VOLTAGE REGULATION	± 1.0 %	± 1.0 %	With 4% ENGINE GOVERNING
SUSTAINED SHORT CIRCUIT	SERIES 4 CONTROL DOES NOT SUSTAIN A SHORT CIRCUIT CURRENT		

INSULATION SYSTEM	CLASS H		
PROTECTION	IP23		
RATED POWER FACTOR	0.8		
STATOR WINDING	SINGLE LAYER CONCENTRIC		
WINDING PITCH	TWO THIRDS		
WINDING LEADS	4		
MAIN STATOR RESISTANCE	0.024 Ohms AT 22°C SERIES CONNECTED		
MAIN ROTOR RESISTANCE	0.83 Ohms at 22°C		
EXCITER STATOR RESISTANCE	20 Ohms at 22°C		
EXCITER ROTOR RESISTANCE	0.078 Ohms PER PHASE AT 22°C		
R.F.I. SUPPRESSION	BS EN 61000-6-2 & BS EN 61000-6-4, VDE 0875G, VDE 0875N. refer to factory for others		
WAVEFORM DISTORTION	NO LOAD < 1.5% NON-DISTORTING LINEAR LOAD < 5.0%		
MAXIMUM OVERSPEED	2250 Rev/Min		
BEARING DRIVE END	BALL. 6312-2RS (ISO)		
BEARING NON-DRIVE END	BALL. 6309-2RS (ISO)		

	1 BEARING	2 BEARING
WEIGHT COMP. GENERATOR	337 kg	350 kg
WEIGHT WOUND STATOR	120 kg	120 kg
WEIGHT WOUND ROTOR	110.7 kg	102.3 kg
WR ² INERTIA	0.6071 kgm ²	0.5754 kgm ²
SHIPPING WEIGHTS in a crate	360 kg	371 kg
PACKING CRATE SIZE	105 x 57 x 96(cm)	105 x 57 x 96(cm)
TELEPHONE INTERFERENCE	THF<2%	TIF<50

COOLING AIR	0.281 m ³ /sec 595 cfm		
VOLTAGE SERIES	220	230	240
VOLTAGE PARALLEL	110	115	120
KVA BASE RATING FOR REACTANCE VALUES	60	60	60
X _d DIR. AXIS SYNCHRONOUS	2.95	2.70	2.48
X' _d DIR. AXIS TRANSIENT	0.24	0.22	0.20
X'' _d DIR. AXIS SUBTRANSIENT	0.17	0.15	0.14
X _q QUAD. AXIS REACTANCE	1.36	1.25	1.14
X'' _q QUAD. AXIS SUBTRANSIENT	0.15	0.14	0.13
X _L LEAKAGE REACTANCE	0.09	0.08	0.07
X ₂ NEGATIVE SEQUENCE	0.15	0.14	0.13
X ₀ ZERO SEQUENCE	0.11	0.10	0.10

REACTANCES ARE SATURATED

T' _d TRANSIENT TIME CONST.	0.03s
T'' _d SUB-TRANSTIME CONST.	0.008s
T' _{do} O.C. FIELD TIME CONST.	0.75s
T _a ARMATURE TIME CONST.	0.0065s
SHORT CIRCUIT RATIO	1/X _d

UCI224F
Winding 06

STAMFORD

SINGLE PHASE EFFICIENCY CURVES

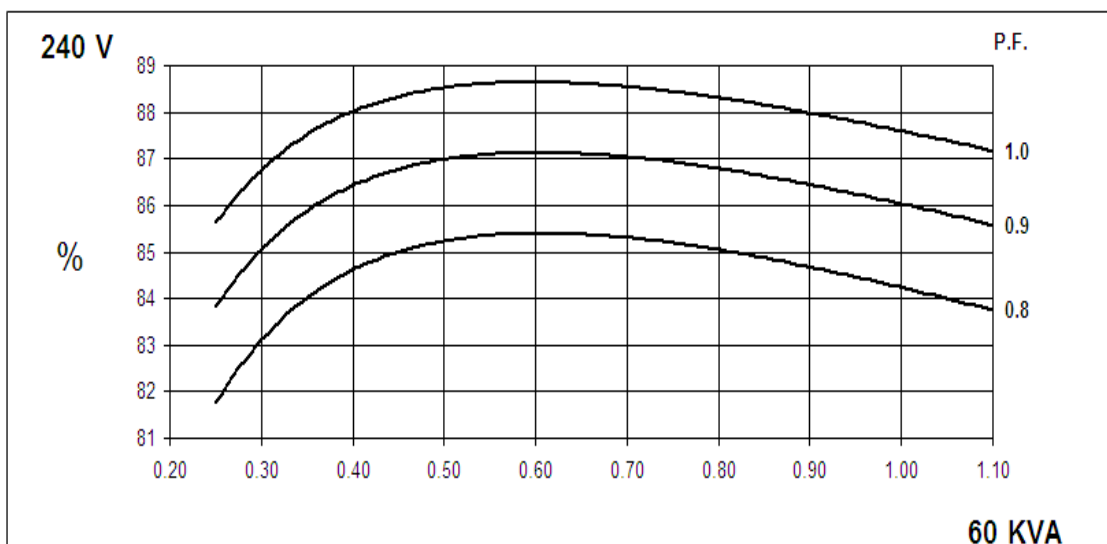
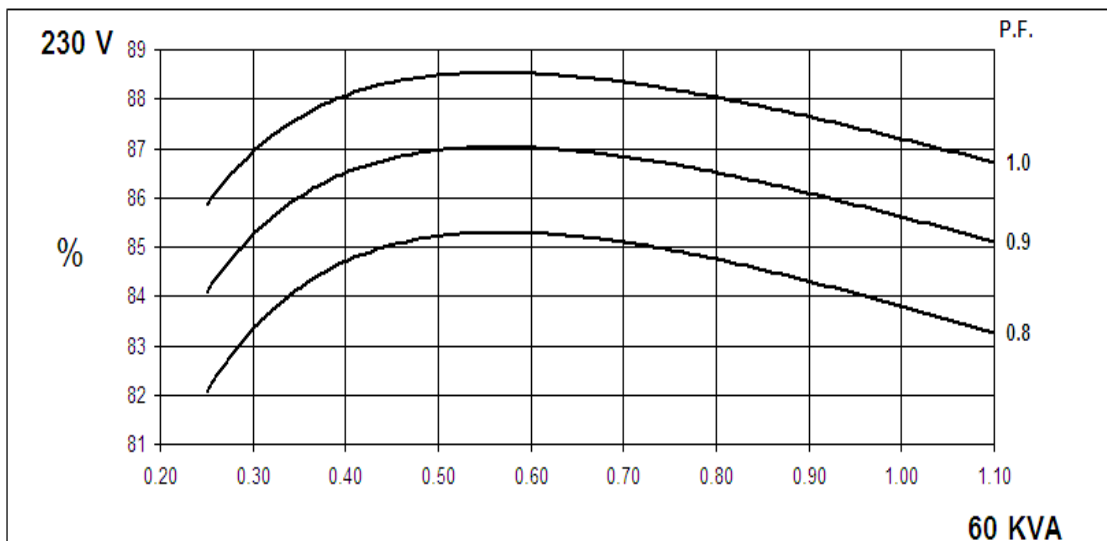
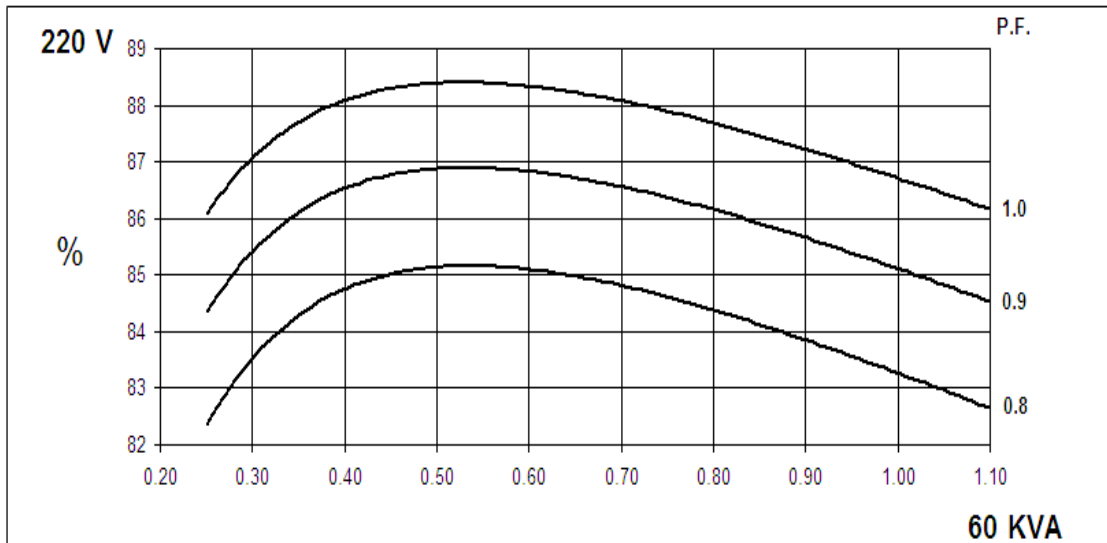

UCI224F
Winding 06

STAMFORD

SX

Locked Rotor Motor Starting Curves

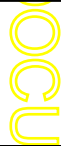
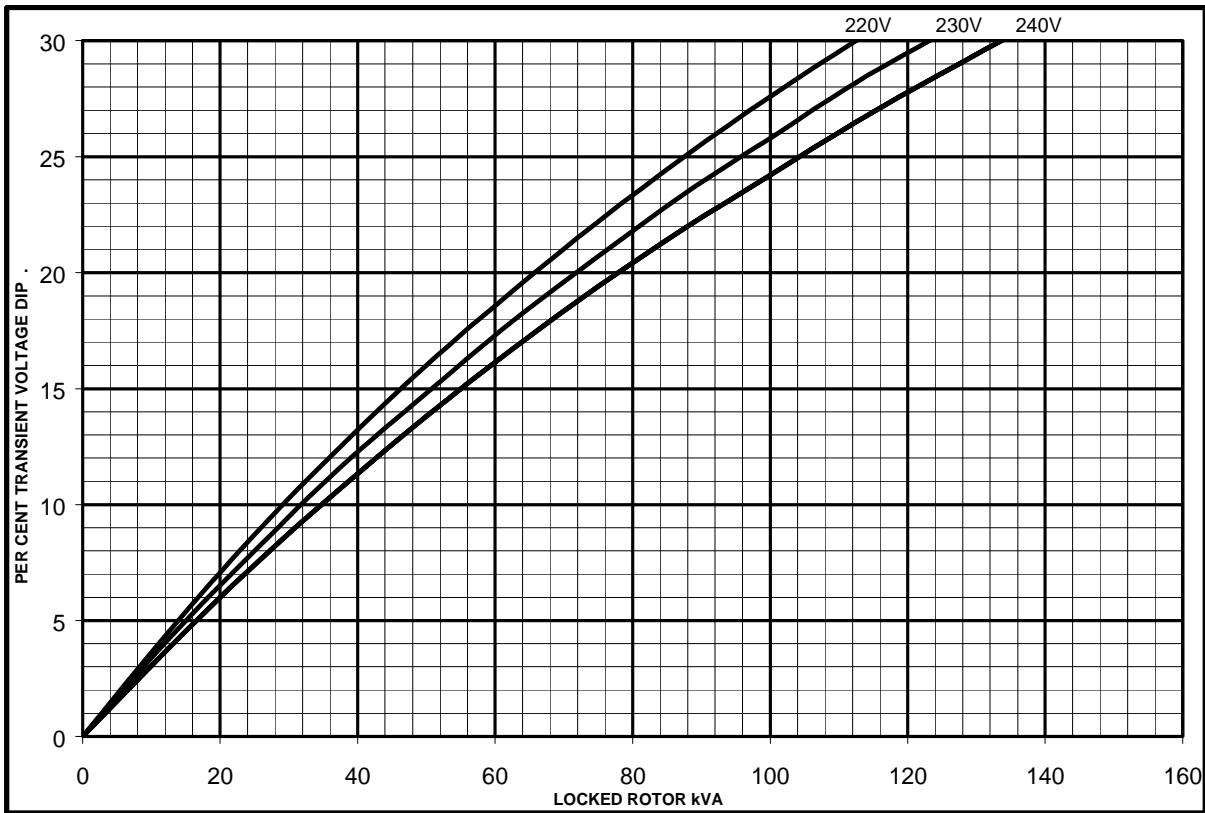

MX

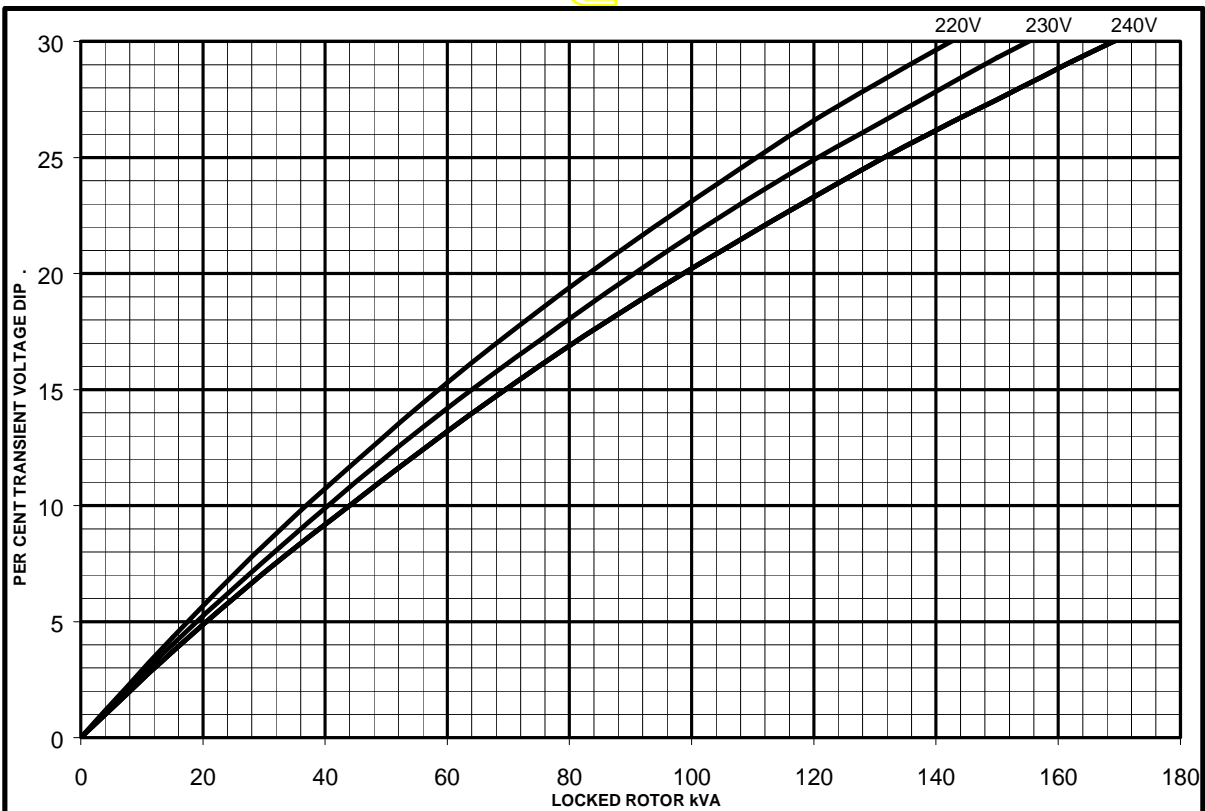

UCI224F
Winding 06

Short Circuit Decrement Curve. No-load Excitation at Rated Speed
Based on series connection.

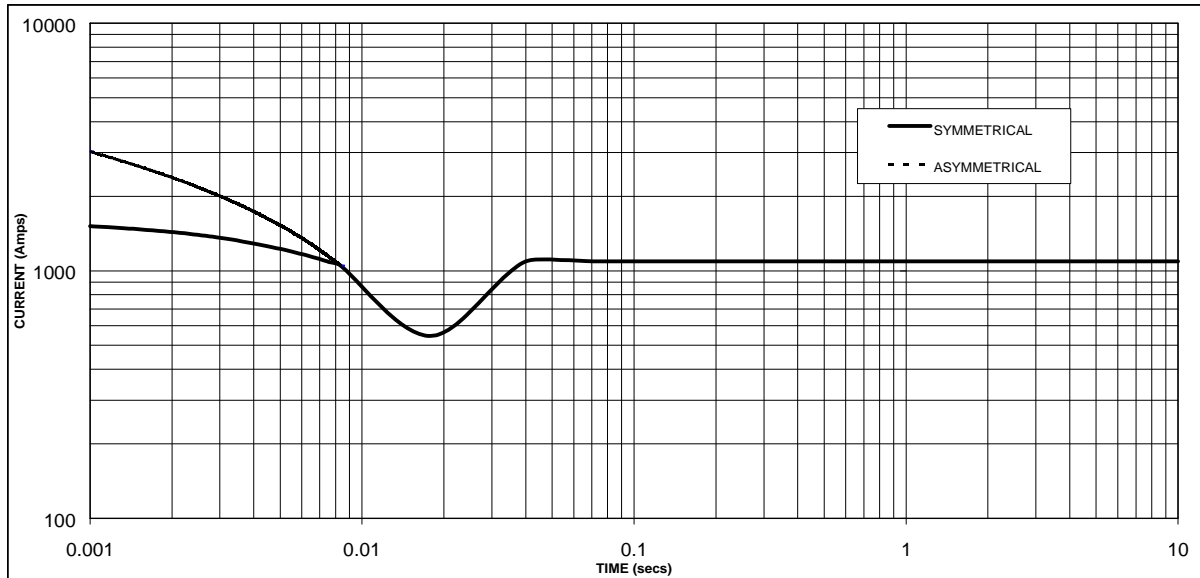

Sustained Short Circuit = 1090 Amps

Note

The following multiplication factors should be used to adjust the values from curve between time 0.001 seconds and the minimum current point in respect of nominal operating voltage :

Voltage	Factor
220V	X 1.00
230V	X 1.05
240V	X 1.09

The sustained current value is constant irrespective of voltage level

UCI224F
Winding 06

STAMFORD

60Hz

RATINGS

Class - Temp Rise	Cont. F - 105/40°C 0.8pf			Cont. H - 125/40°C 0.8pf			Cont. F - 105/40°C 1.0pf			Cont. H - 125/40°C 1.0pf		
	Series (V)	220	230	240	220	230	240	220	230	240	220	230
Parallel (V)	110	115	120	110	115	120	110	115	120	110	115	120
kVA	56.9	56.9	56.9	60.0	60.0	60.0	56.9	56.9	56.9	60.0	60.0	60.0
kW	45.5	45.5	45.5	48.0	48.0	48.0	56.9	56.9	56.9	60.0	60.0	60.0
Efficiency (%)	83.6	84.1	84.5	83.3	83.8	84.2	87.0	87.4	87.8	86.7	87.2	87.6
kW Input	54.5	54.2	53.9	57.6	57.3	57.0	65.4	65.1	64.8	69.2	68.8	68.5

APPROVE

DIMENSIONS

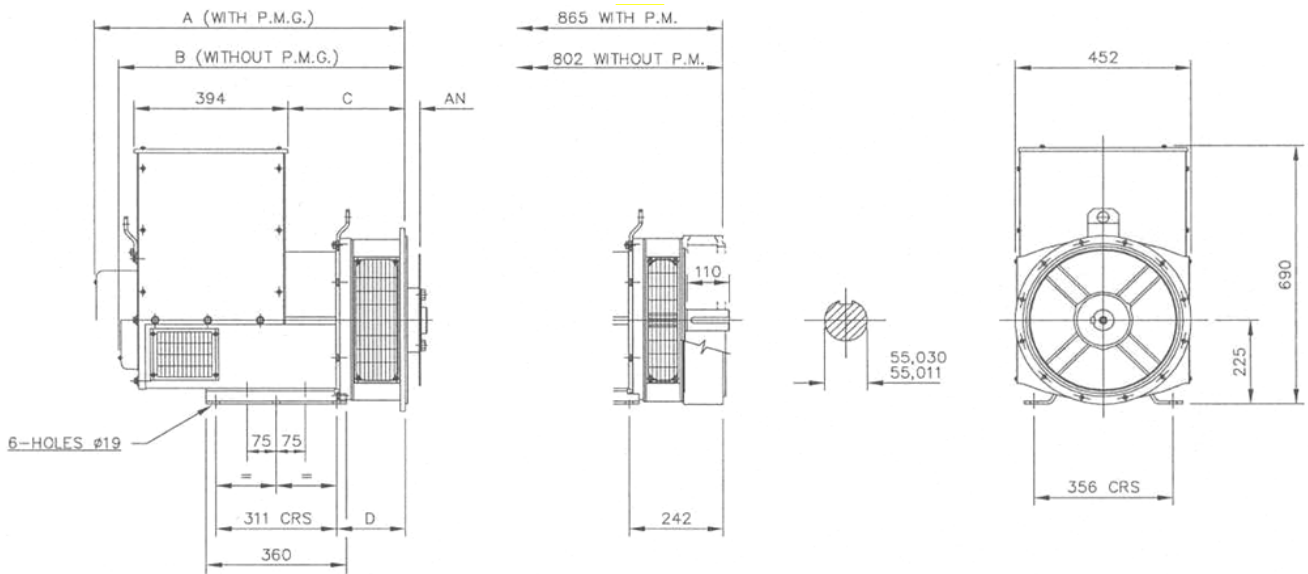

SINGLE BEARING MACHINES ONLY						
ADAPTOR	A	B	C	D	COUPLING DISCS	AN
SAE 1	814,3	751,3	314,3	191,3	SAE 8	61,90
SAE 2	800	737	300	177	SAE 10	53,98
SAE 3	800	737	300	177	SAE 11,5	39,68
SAE 4	800	737	300	177	SAE 14	25,40

APPROVED DOCUMENT

STAMFORD

Head Office Address:
Barnack Road, Stamford
Lincolnshire, PE9 2NB
United Kingdom
Tel: +44 (0) 1780 484000
Fax: +44 (0) 1780 484100

www.cumminsgeneratortechnologies.com

Copyright 2010, Cummins Generator Technologies Ltd, All Rights Reserved
Stamford and AvK are registered trade marks of Cummins Generator Technologies Ltd
Cummins and the Cummins logo are registered trade marks of Cummins Inc.

STAMFORD®

UCI224F - Winding 311

Technical  Data Sheet

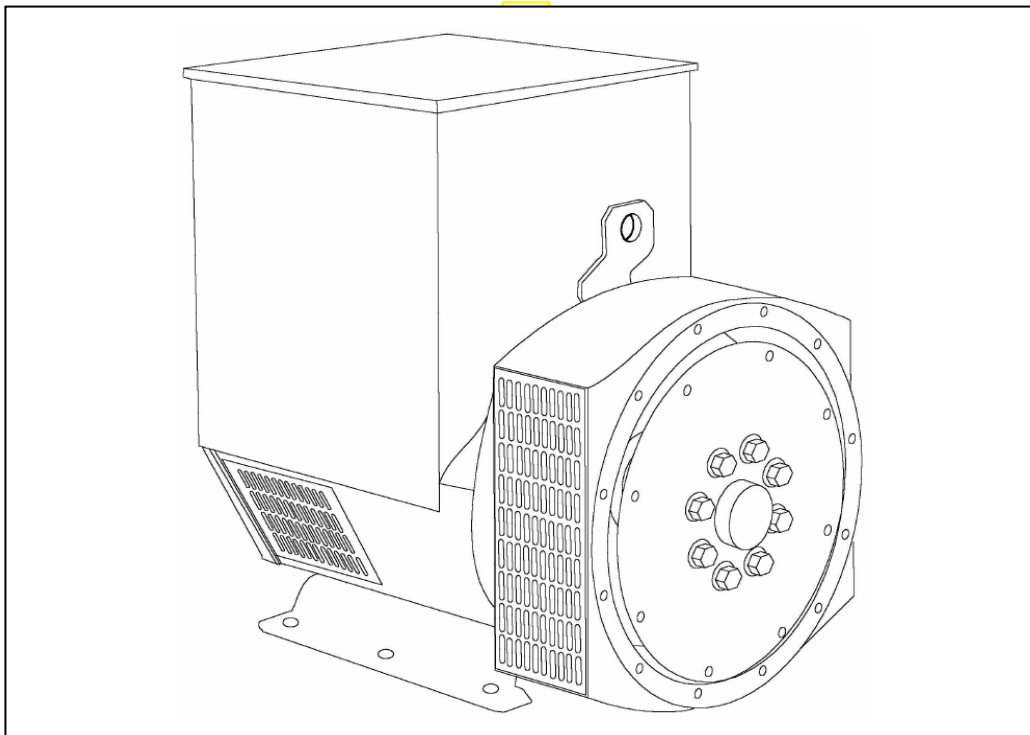

UCI224F

SPECIFICATIONS & OPTIONS

STAMFORD

STANDARDS

Stamford industrial generators meet the requirements of BS EN 60034 and the relevant section of other international standards such as BS5000, VDE 0530, NEMA MG1-32, IEC34, CSA C22.2-100, AS1359.

Other standards and certifications can be considered on request.

VOLTAGE REGULATORS

SX460 AVR - STANDARD

With this self excited control system the main stator supplies power via the Automatic Voltage Regulator (AVR) to the exciter stator. The high efficiency semiconductors of the AVR ensure positive build-up from initial low levels of residual voltage.

The exciter rotor output is fed to the main rotor through a three phase full wave bridge rectifier. This rectifier is protected by a surge suppressor against surges caused, for example, by short circuit.

AS440 AVR

With this self-excited system the main stator provides power via the AVR to the exciter stator. The high efficiency semiconductors of the AVR ensure positive build-up from initial low levels of residual voltage.

The exciter rotor output is fed to the main rotor through a three-phase full-wave bridge rectifier. The rectifier is protected by a surge suppressor against surges caused, for example, by short circuit or out-of-phase paralleling.

The AS440 will support a range of electronic accessories, including a 'droop' Current Transformer (CT) to permit parallel operation with other ac generators.

MX341 AVR

This sophisticated AVR is incorporated into the Stamford Permanent Magnet Generator (PMG) control system.

The PMG provides power via the AVR to the main exciter, giving a source of constant excitation power independent of generator output. The main exciter output is then fed to the main rotor, through a full wave bridge, protected by a surge suppressor. The AVR has in-built protection against sustained over-excitation, caused by internal or external faults. This de-excites the machine after a minimum of 5 seconds.

An engine relief load acceptance feature can enable full load to be applied to the generator in a single step.

If three-phase sensing is required with the PMG system the MX321 AVR must be used.

We recommend three-phase sensing for applications with greatly unbalanced or highly non-linear loads.

MX321 AVR

The most sophisticated of all our AVRs combines all the features of the MX341 with, additionally, three-phase rms sensing, for improved regulation and performance.

Over voltage protection is built-in and short circuit current level adjustments is an optional facility.

WINDINGS & ELECTRICAL PERFORMANCE

All generator stators are wound to 2/3 pitch. This eliminates triplen (3rd, 9th, 15th ...) harmonics on the voltage waveform and is found to be the optimum design for trouble-free supply of non-linear loads. The 2/3 pitch design avoids excessive neutral currents sometimes seen with higher winding pitches, when in parallel with the mains. A fully connected damper winding reduces oscillations during paralleling. This winding, with the 2/3 pitch and carefully selected pole and tooth designs, ensures very low waveform distortion.

TERMINALS & TERMINAL BOX

Standard generators are 3-phase reconnectable with 12 ends brought out to the terminals, which are mounted on a cover at the non-drive end of the generator. A sheet steel terminal box contains the AVR and provides ample space for the customers' wiring and gland arrangements. It has removable panels for easy access.

SHAFT & KEYS

All generator rotors are dynamically balanced to better than BS6861:Part 1 Grade 2.5 for minimum vibration in operation.

INSULATION/IMPREGNATION

The insulation system is class 'H'.

All wound components are impregnated with materials and processes designed specifically to provide the high build required for static windings and the high mechanical strength required for rotating components.

QUALITY ASSURANCE

Generators are manufactured using production procedures having a quality assurance level to BS EN ISO 9001.

The stated voltage regulation may not be maintained in the presence of certain radio transmitted signals. Any change in performance will fall within the limits of Criteria 'B' of EN 61000-6-2:2001. At no time will the steady-state voltage regulation exceed 2%.

DE RATES

All values tabulated on page 8 are subject to the following reductions

5% when air inlet filters are fitted.

3% for every 500 metres by which the operating altitude exceeds 1000 metres above mean sea level.

3% for every 5°C by which the operational ambient temperature exceeds 40°C.

Note: Requirement for operating in an ambient exceeding 60°C must be referred to the factory.

NB Continuous development of our products entitles us to change specification details without notice, therefore they must not be regarded as binding.

Front cover drawing typical of product range.

APPROVED DOCUMENT

50
Hz

UCI224F
Winding 311

STAMFORD

THREE PHASE EFFICIENCY CURVES

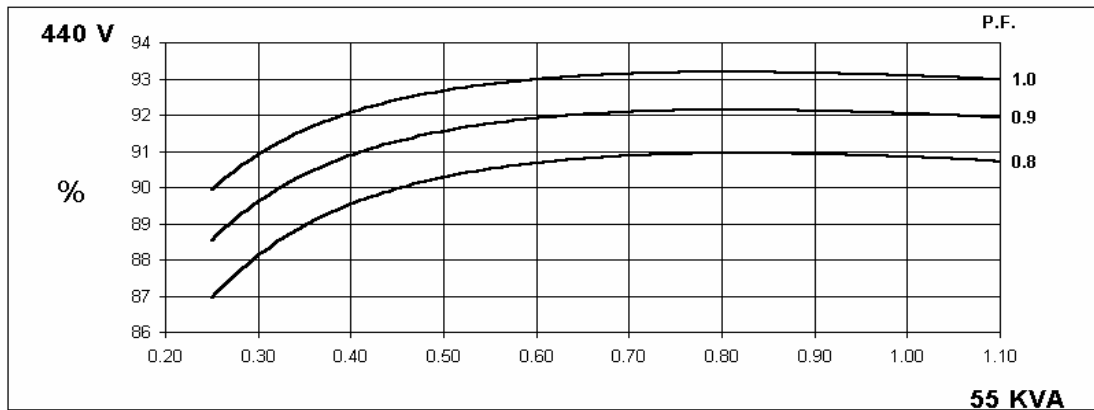
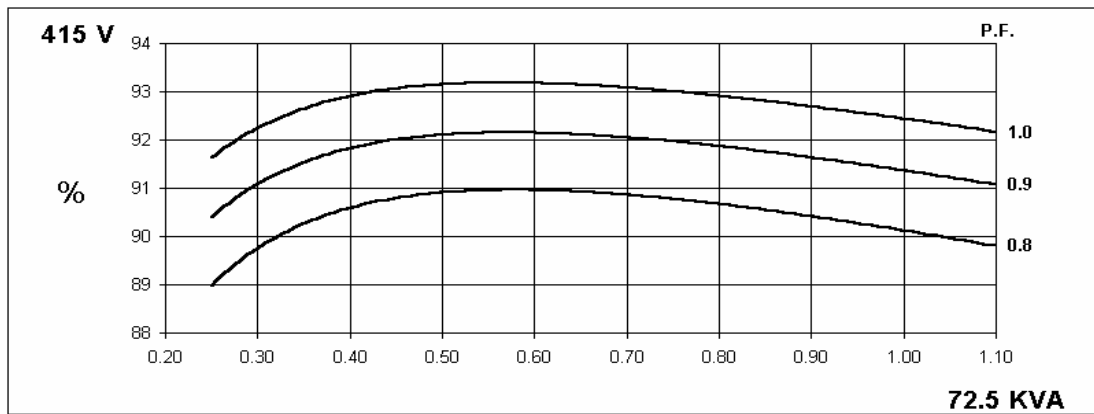
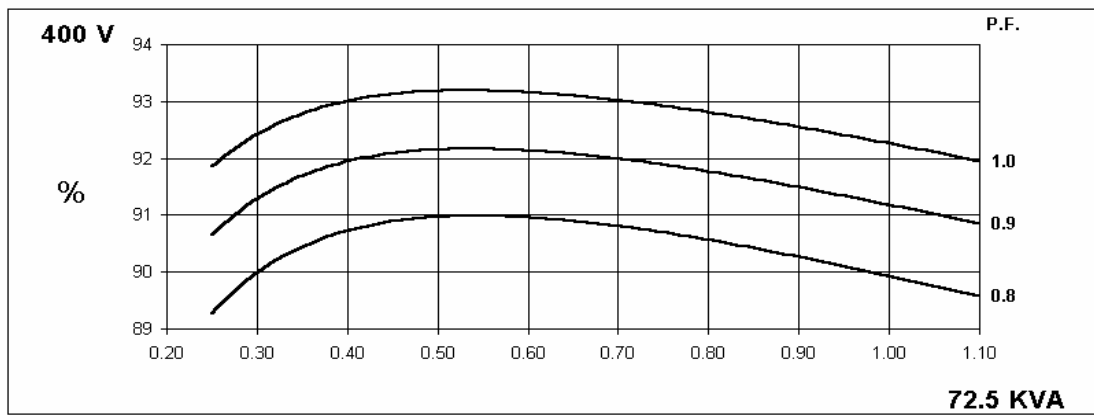
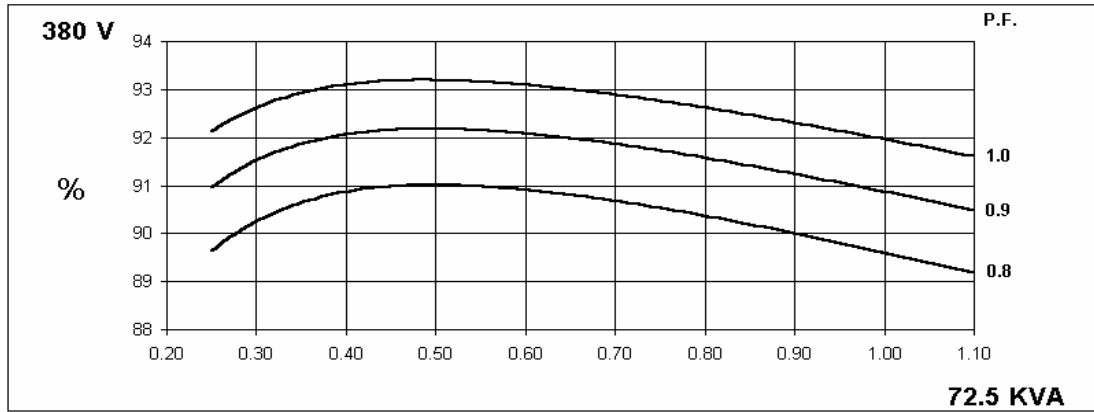

60
Hz

UCI224F
Winding 311

STAMFORD

THREE PHASE EFFICIENCY CURVES

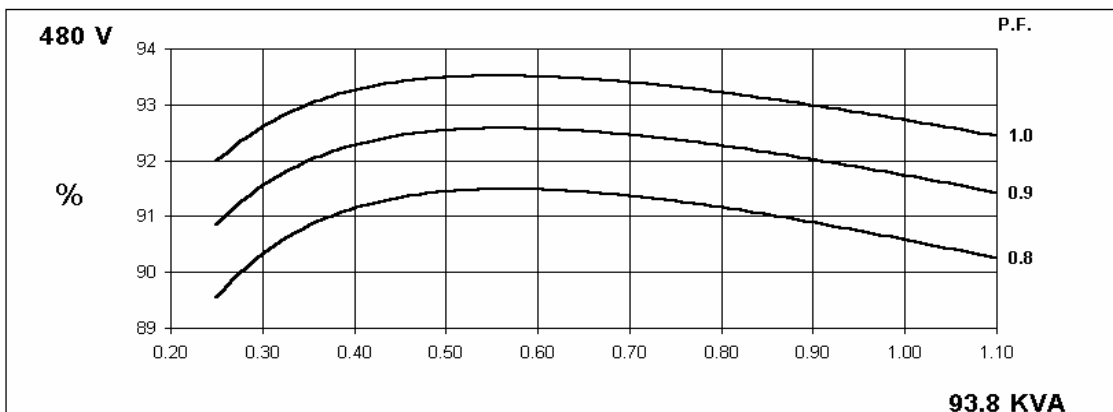
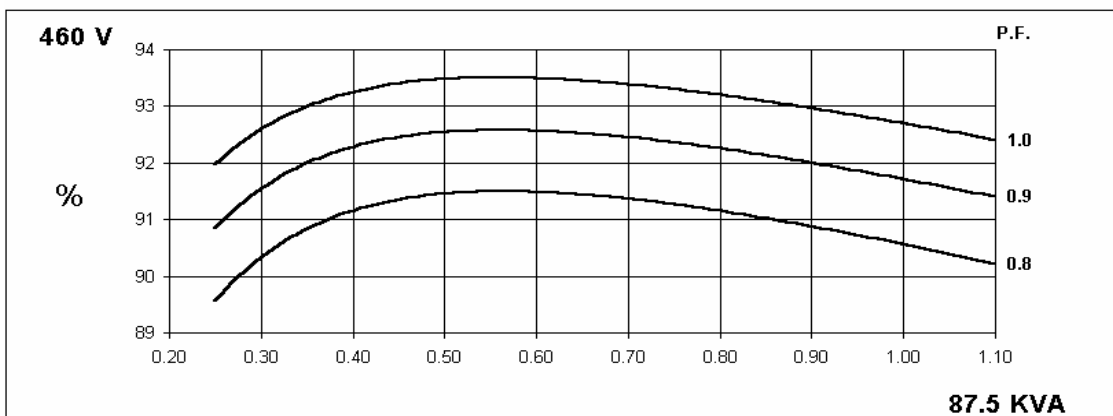
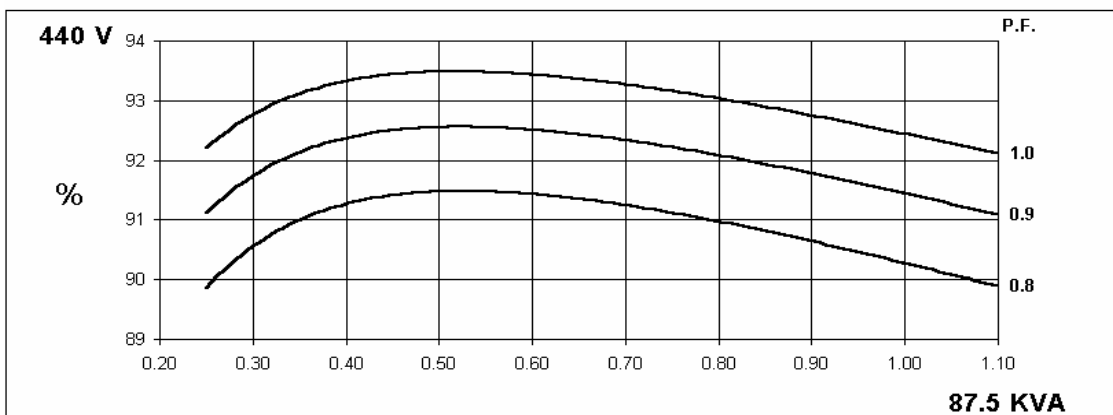
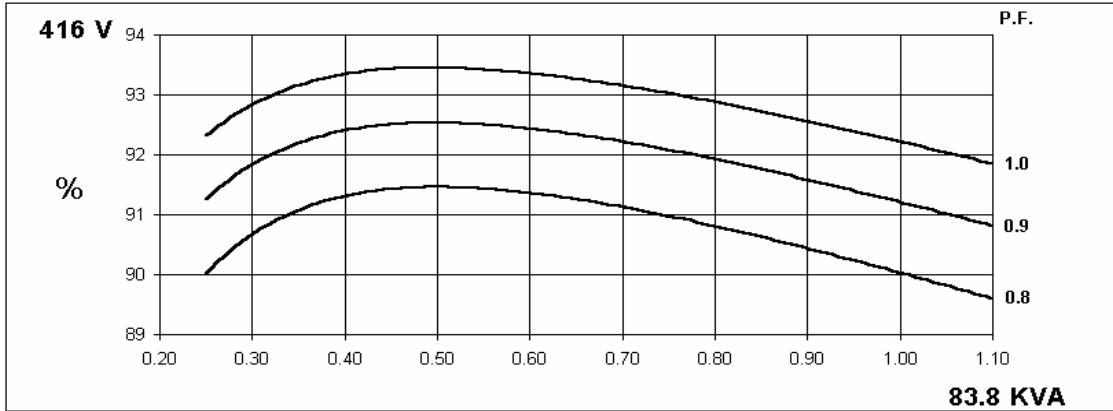

Locked Rotor Motor Starting Curve

50
Hz

MX

SX

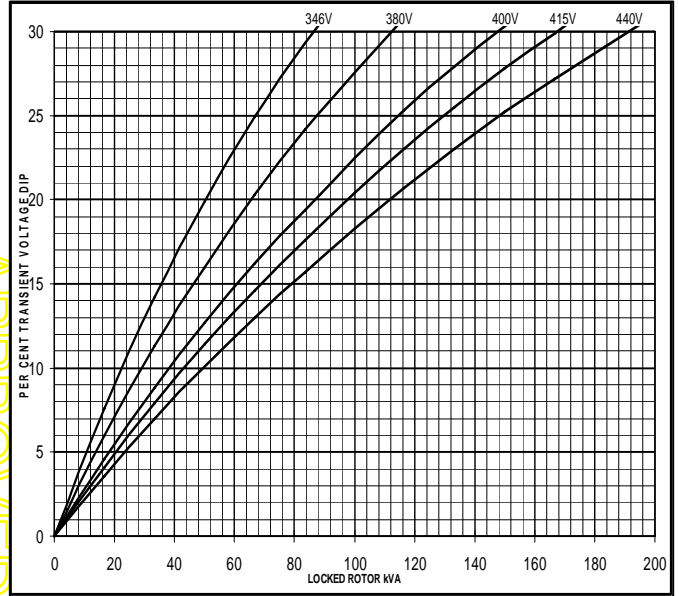

60
Hz

MX

SX

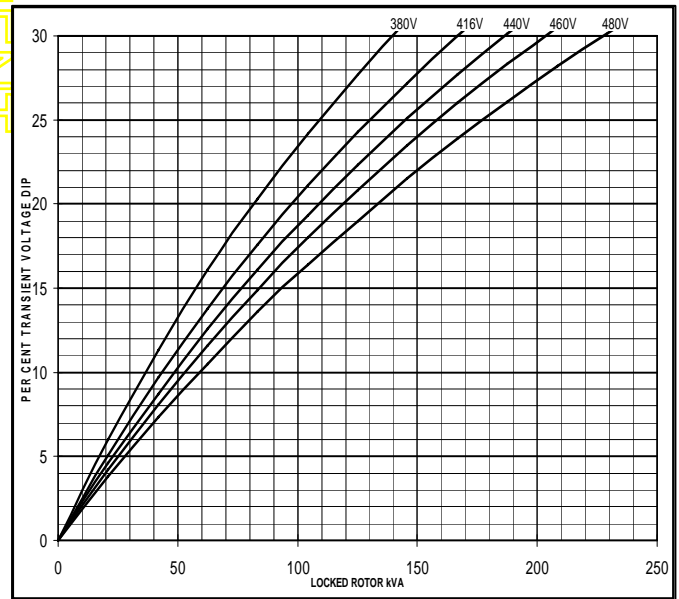
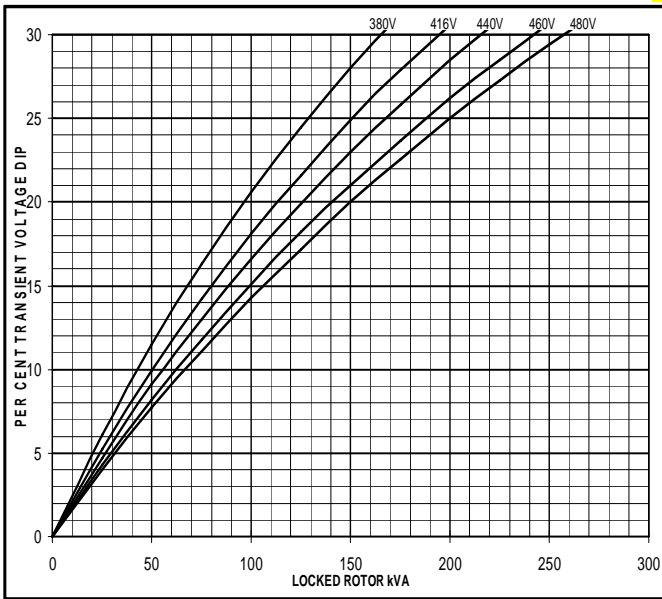

**Three-phase Short Circuit Decrement Curve. No-load Excitation at Rated Speed
Based on star (wye) connection.**

50
Hz

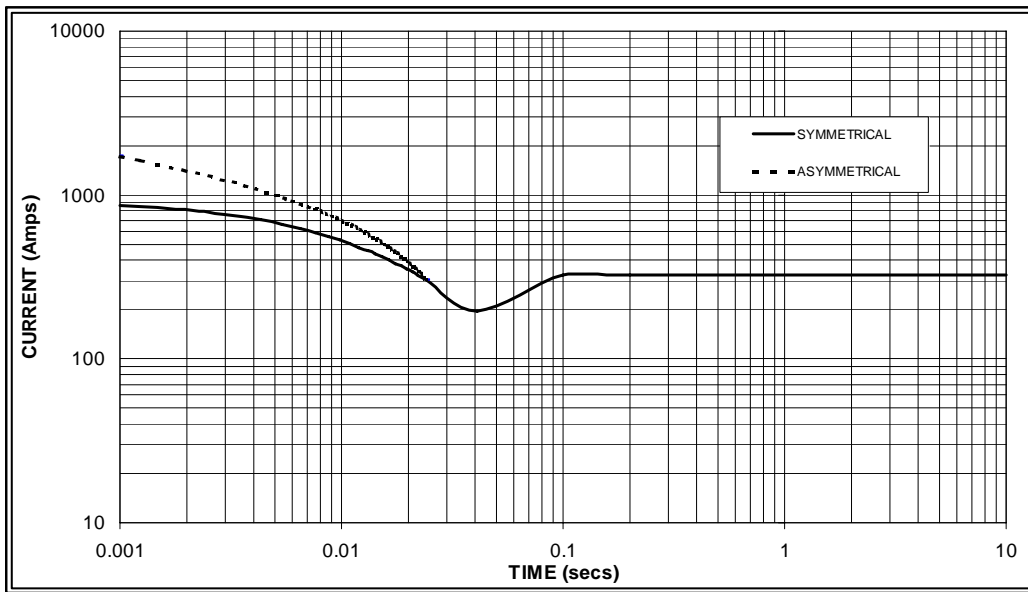

Sustained Short Circuit = 325 Amps



60
Hz

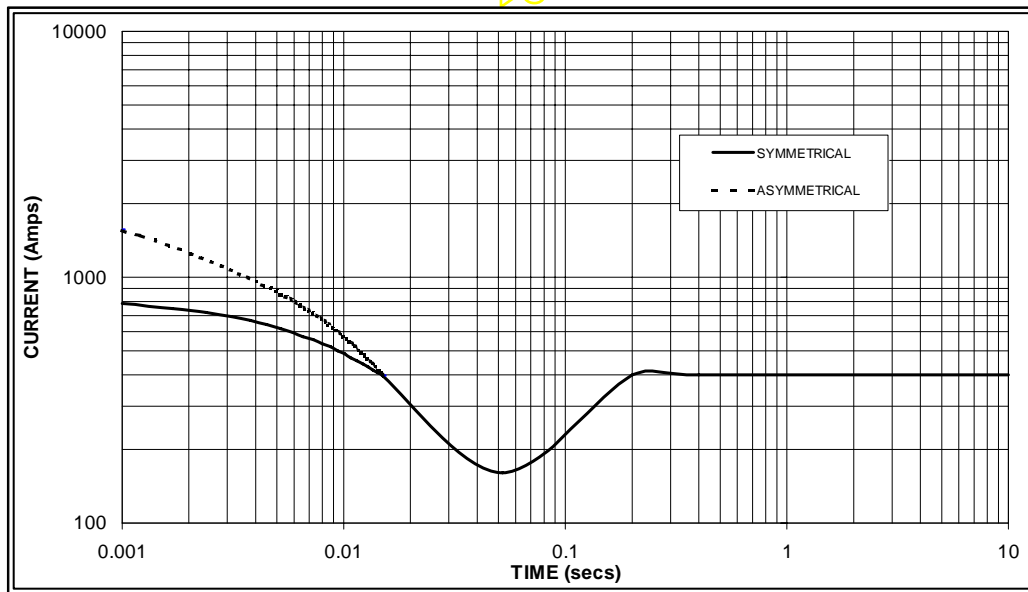

Sustained Short Circuit = 400 Amps

Note 1

The following multiplication factors should be used to adjust the values from curve between time 0.001 seconds and the minimum current point in respect of nominal operating voltage :

50Hz		60Hz	
Voltage	Factor	Voltage	Factor
380v	X 1.00	416v	X 1.00
400v	X 1.07	440v	X 1.06
415v	X 1.12	460v	X 1.12
440v	X 1.18	480v	X 1.17

The sustained current value is constant irrespective of voltage level

Note 2

The following multiplication factor should be used to convert the values calculated in accordance with NOTE 1 to those applicable to the various types of short circuit :

	3-phase	2-phase L-L	1-phase L-N
Instantaneous	x 1.00	x 0.87	x 1.30
Minimum	x 1.00	x 1.80	x 3.20
Sustained	x 1.00	x 1.50	x 2.50
Max. sustained duration	10 sec.	5 sec.	2 sec.

All other times are unchanged

Note 3

Curves are drawn for Star (Wye) connected machines. For other connection the following multipliers should be applied to current values as shown :

Parallel Star = Curve current value X 2

Series Delta = Curve current value X 1.732

UCI224F
Winding 311 / 0.8 Power Factor

RATINGS

Class - Temp Rise	Cont. F - 105/40°C				Cont. H - 125/40°C				Standby - 150/40°C				Standby - 163/27°C				
50 Hz	Series Star (V)	380	400	415	440	380	400	415	440	380	400	415	440	380	400	415	440
	Parallel Star (V)	190	200	208	220	190	200	208	220	190	200	208	220	190	200	208	220
	Series Delta (V)	220	230	240	254	220	230	240	254	220	230	240	254	220	230	240	254
	kVA	65.0	65.0	65.0	48.7	72.5	72.5	72.5	55.0	77.0	77.0	77.0	58.0	80.0	80.0	80.0	60.5
	kW	52.0	52.0	52.0	39.0	58.0	58.0	58.0	44.0	61.6	61.6	61.6	46.4	64.0	64.0	64.0	48.4
	Efficiency (%)	90.0	90.3	90.4	90.9	89.6	89.9	90.1	90.8	89.4	89.7	89.9	90.8	89.2	89.6	89.8	90.7
	kW Input	57.8	57.6	57.5	42.9	64.7	64.5	64.4	48.5	68.9	68.7	68.5	51.1	71.7	71.4	71.3	53.4

60 Hz	Series Star (V)	416	440	460	480	416	440	460	480	416	440	460	480	416	440	460	480
	Parallel Star (V)	208	220	230	240	208	220	230	240	208	220	230	240	208	220	230	240
	Delta (V)	240	254	266	277	240	254	266	277	240	254	266	277	240	254	266	277
	kVA	75.0	78.1	78.1	82.5	83.8	87.5	87.5	93.8	88.8	92.5	92.5	100.0	91.9	95.0	95.0	102.5
	kW	60.0	62.5	62.5	66.0	67.0	70.0	70.0	75.0	71.0	74.0	74.0	80.0	73.5	76.0	76.0	82.0
	Efficiency (%)	90.5	90.7	90.9	91.0	90.0	90.3	90.6	90.6	89.8	90.1	90.4	90.4	89.6	89.9	90.3	90.3
	kW Input	66.3	68.9	68.7	72.5	74.5	77.5	77.3	82.8	79.1	82.1	81.9	88.5	82.1	84.5	84.2	90.8

DIMENSIONS

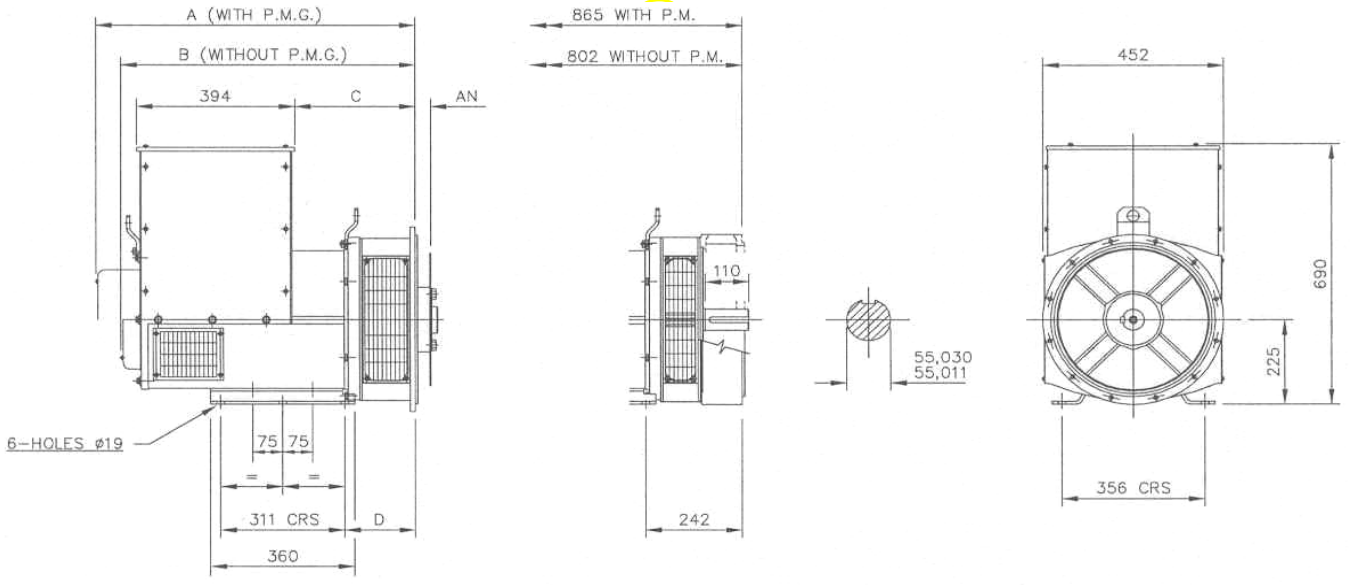

SINGLE BEARING MACHINES ONLY						
ADAPTOR	A	B	C	D	COUPLING DISCS	AN
SAE 1	814,3	751,3	314,3	191,3	SAE 8	61,90
SAE 2	800	737	300	177	SAE 10	53,98
SAE 3	800	737	300	177	SAE 11,5	39,68
SAE 4	800	737	300	177	SAE 14	25,40

APPROVED DOCUMENT

STAMFORD

Head Office Address:
Barnack Road, Stamford
Lincolnshire, PE9 2NB
United Kingdom
Tel: +44 (0) 1780 484000
Fax: +44 (0) 1780 484100

www.cumminsgeneratortechnologies.com

Copyright 2010, Cummins Generator Technologies Ltd, All Rights Reserved
Stamford and AvK are registered trade marks of Cummins Generator Technologies Ltd
Cummins and the Cummins logo are registered trade marks of Cummins Inc.

STAMFORD®

UCI224F - Winding 17

Technical Data Sheet

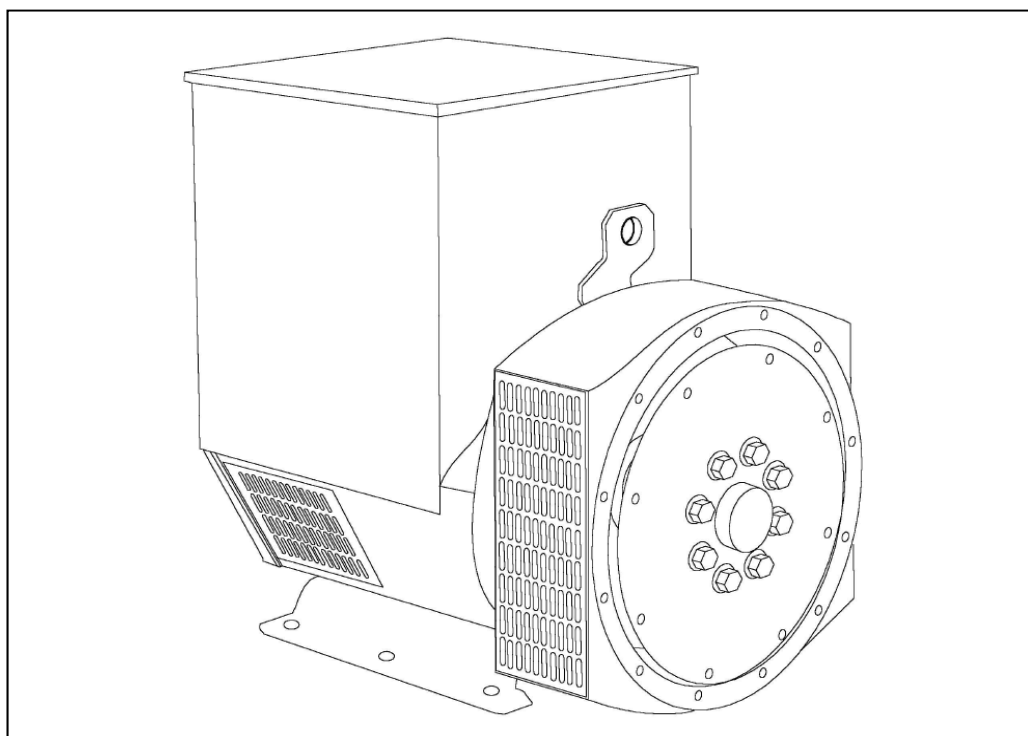

SPECIFICATIONS & OPTIONS**STANDARDS**

Stamford industrial generators meet the requirements of BS EN 60034 and the relevant section of other international standards such as BS5000, VDE 0530, NEMA MG1-32, IEC34, CSA C22.2-100, AS1359.

Other standards and certifications can be considered on request.

VOLTAGE REGULATORS**SX460 AVR - STANDARD**

With this self excited control system the main stator supplies power via the Automatic Voltage Regulator (AVR) to the exciter stator. The high efficiency semiconductors of the AVR ensure positive build-up from initial low levels of residual voltage.

The exciter rotor output is fed to the main rotor through a three phase full wave bridge rectifier. This rectifier is protected by a surge suppressor against surges caused, for example, by short circuit.

AS440 AVR

With this self-excited system the main stator provides power via the AVR to the exciter stator. The high efficiency semi-conductors of the AVR ensure positive build-up from initial low levels of residual voltage.

The exciter rotor output is fed to the main rotor through a three-phase full-wave bridge rectifier. The rectifier is protected by a surge suppressor against surges caused, for example, by short circuit or out-of-phase paralleling.

The AS440 will support a range of electronic accessories, including a 'droop' Current Transformer (CT) to permit parallel operation with other ac generators.

MX341 AVR

This sophisticated AVR is incorporated into the Stamford Permanent Magnet Generator (PMG) control system.

The PMG provides power via the AVR to the main exciter, giving a source of constant excitation power independent of generator output. The main exciter output is then fed to the main rotor, through a full wave bridge, protected by a surge suppressor. The AVR has in-built protection against sustained over-excitation, caused by internal or external faults. This de-excites the machine after a minimum of 5 seconds.

An engine relief load acceptance feature can enable full load to be applied to the generator in a single step.

If three-phase sensing is required with the PMG system the MX321 AVR must be used.

We recommend three-phase sensing for applications with greatly unbalanced or highly non-linear loads.

MX321 AVR

The most sophisticated of all our AVRs combines all the features of the MX341 with, additionally, three-phase rms sensing, for improved regulation and performance.

Over voltage protection is built-in and short circuit current level adjustments is an optional facility.

WINDINGS & ELECTRICAL PERFORMANCE

All generator stators are wound to 2/3 pitch. This eliminates triplen (3rd, 9th, 15th ...) harmonics on the voltage waveform and is found to be the optimum design for trouble-free supply of non-linear loads. The 2/3 pitch design avoids excessive neutral currents sometimes seen with higher winding pitches, when in parallel with the mains. A fully connected damper winding reduces oscillations during paralleling. This winding, with the 2/3 pitch and carefully selected pole and tooth designs, ensures very low waveform distortion.

TERMINALS & TERMINAL BOX

Standard generators are 3-phase reconnectable with 12 ends brought out to the terminals, which are mounted on a cover at the non-drive end of the generator. A sheet steel terminal box contains the AVR and provides ample space for the customers' wiring and gland arrangements. It has removable panels for easy access.

SHAFT & KEYS

All generator rotors are dynamically balanced to better than BS6861:Part 1 Grade 2.5 for minimum vibration in operation. Two bearing generators are balanced with a half key.

INSULATION/IMPREGNATION

The insulation system is class 'H'.

All wound components are impregnated with materials and processes designed specifically to provide the high build required for static windings and the high mechanical strength required for rotating components.

QUALITY ASSURANCE

Generators are manufactured using production procedures having a quality assurance level to BS EN ISO 9001.

The stated voltage regulation may not be maintained in the presence of certain radio transmitted signals. Any change in performance will fall within the limits of Criteria 'B' of EN 61000-6-2:2001. At no time will the steady-state voltage regulation exceed 2%.

DE RATES

All values tabulated on page 6 are subject to the following reductions

5% when air inlet filters are fitted.

3% for every 500 metres by which the operating altitude exceeds 1000 metres above mean sea level.

3% for every 5°C by which the operational ambient temperature exceeds 40°C.

Note: Requirement for operating in an ambient exceeding 60°C must be referred to the factory.

NB Continuous development of our products entitles us to change specification details without notice, therefore they must not be regarded as binding.

Front cover drawing typical of product range.

UCI224F

STAMFORD**WINDING 17**

CONTROL SYSTEM	SEPARATELY EXCITED BY P.M.G.		
A.V.R.	MX321	MX341	
VOLTAGE REGULATION	± 0.5 %	± 1.0 %	With 4% ENGINE GOVERNING
SUSTAINED SHORT CIRCUIT	REFER TO SHORT CIRCUIT DECREMENT CURVES (page 5)		

CONTROL SYSTEM	SELF EXCITED		
A.V.R.	SX460	AS440	
VOLTAGE REGULATION	± 1.0 %	± 1.0 %	With 4% ENGINE GOVERNING
SUSTAINED SHORT CIRCUIT	SERIES 4 CONTROL DOES NOT SUSTAIN A SHORT CIRCUIT CURRENT		

INSULATION SYSTEM	CLASS H	
PROTECTION	IP23	
RATED POWER FACTOR	0.8	
STATOR WINDING	DOUBLE LAYER CONCENTRIC	
WINDING PITCH	TWO THIRDS	
WINDING LEADS	12	
STATOR WDG. RESISTANCE	0.102 Ohms PER PHASE AT 22°C SERIES STAR CONNECTED	
ROTOR WDG. RESISTANCE	0.83 Ohms at 22°C	
EXCITER STATOR RESISTANCE	20 Ohms at 22°C	
EXCITER ROTOR RESISTANCE	0.078 Ohms PER PHASE AT 22°C	
R.F.I. SUPPRESSION	BS EN 61000-6-2 & BS EN 61000-6-4, VDE 0875G, VDE 0875N. refer to factory for others	
WAVEFORM DISTORTION	NO LOAD < 1.5% NON-DISTORTING BALANCED LINEAR LOAD < 5.0%	
MAXIMUM OVERSPEED	2250 Rev/Min	
BEARING DRIVE END	BALL. 6312-2RS (ISO)	
BEARING NON-DRIVE END	BALL. 6309-2RS (ISO)	
	1 BEARING	2 BEARING
WEIGHT COMP. GENERATOR	337 kg	350 kg
WEIGHT WOUND STATOR	120 kg	120 kg
WEIGHT WOUND ROTOR	110.69 kg	102.32 kg
WR ² INERTIA	0.6071 kgm ²	0.5754 kgm ²
SHIPPING WEIGHTS in a crate	360 kg	371 kg
PACKING CRATE SIZE	105 x 57 x 96(cm)	105 x 57 x 96(cm)
TELEPHONE INTERFERENCE	THF<2%	TIF<50
COOLING AIR	0.281 m ³ /sec 595 cfm	
VOLTAGE SERIES STAR	600V	
VOLTAGE PARALLEL STAR	300V	
VOLTAGE SERIES DELTA	346V	
KVA BASE RATING FOR REACTANCE VALUES	94	
X _d DIR. AXIS SYNCHRONOUS	1.86	
X' _d DIR. AXIS TRANSIENT	0.15	
X'' _d DIR. AXIS SUBTRANSIENT	0.10	
X _q QUAD. AXIS REACTANCE	0.86	
X'' _q QUAD. AXIS SUBTRANSIENT	0.10	
X _L LEAKAGE REACTANCE	0.06	
X ₂ NEGATIVE SEQUENCE	0.10	
X ₀ ZERO SEQUENCE	0.07	
REACTANCES ARE SATURATED VALUES ARE PER UNIT AT RATING AND VOLTAGE INDICATED		
T' _d TRANSIENT TIME CONST.	0.03s	
T'' _d SUB-TRANSTIME CONST.	0.008s	
T' _{do} O.C. FIELD TIME CONST.	0.75s	
T _a ARMATURE TIME CONST.	0.0065s	
SHORT CIRCUIT RATIO	1/X _d	

UCI224F
Winding 17

STAMFORD

SX

Locked Rotor Motor Starting Curves

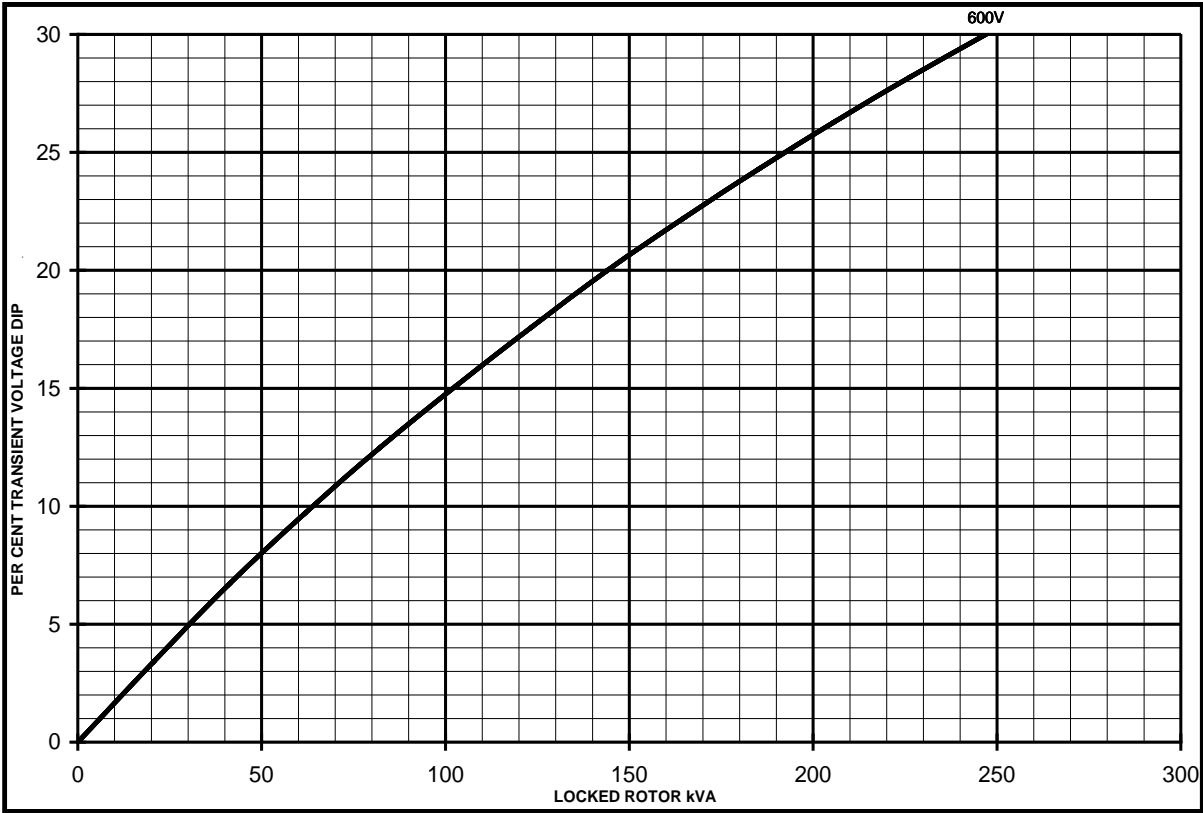

MX

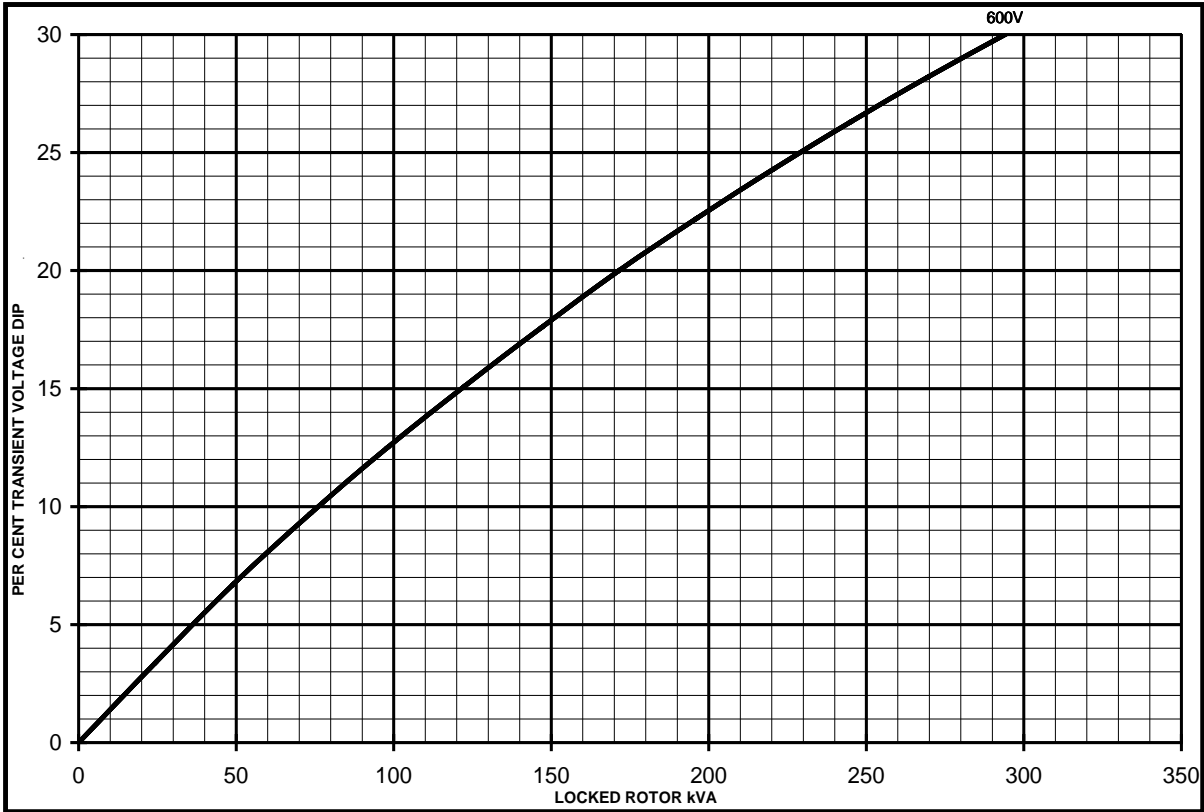

THREE PHASE EFFICIENCY CURVES

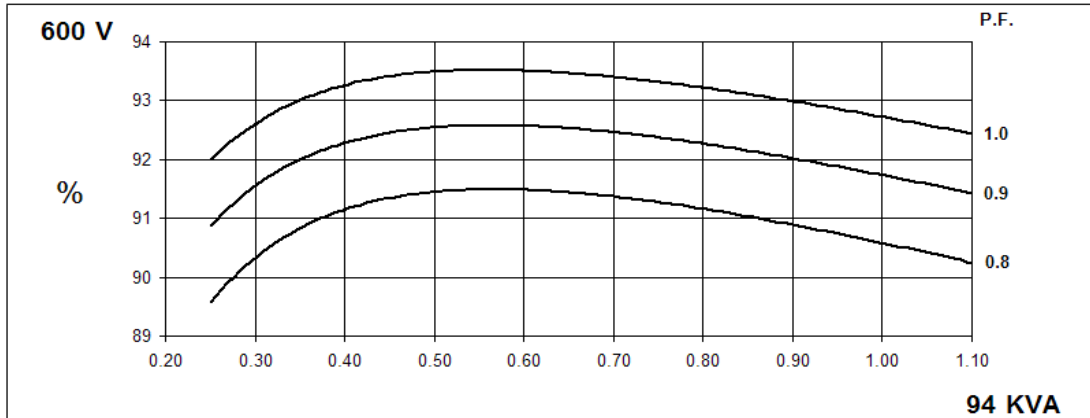

Three-phase Short Circuit Decrement Curve. No-load Excitation at Rated Speed Based on star (wye) connection.

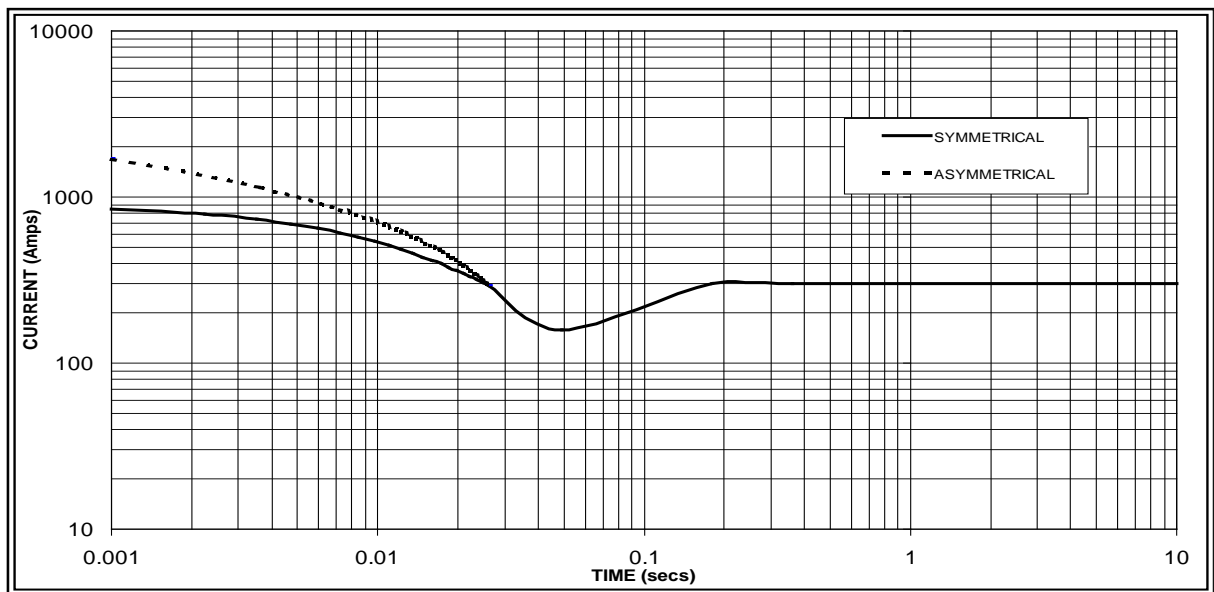

Sustained Short Circuit = 300 Amps

Note

The following multiplication factor should be used to convert the values from curve for the various types of short circuit :

	3-phase	2-phase L-L	1-phase L-N
Instantaneous	x 1.00	x 0.87	x 1.30
Minimum	x 1.00	x 1.80	x 3.20
Sustained	x 1.00	x 1.50	x 2.50
Max. sustained duration	10 sec.	5 sec.	2 sec.

All other times are unchanged

UCI224F

STAMFORD

Winding 17 / 0.8 Power Factor

60Hz

RATINGS

Class - Temp Rise	Cont. F - 105/40°C	Cont. H - 125/40°C	Standby - 150/40°C	Standby - 163/27°C
Series Star (V)	600	600	600	600
Parallel Star (V)	300	300	300	300
Series Delta (V)	346	346	346	346
<hr style="border-top: 1px dashed black;"/>				
kVA	82.5	94.0	98.8	102.5
kW	66.0	75.2	79.0	82.0
Efficiency (%)	91.0	90.6	90.4	90.3
kW Input	72.6	83.0	87.4	90.8

DIMENSIONS

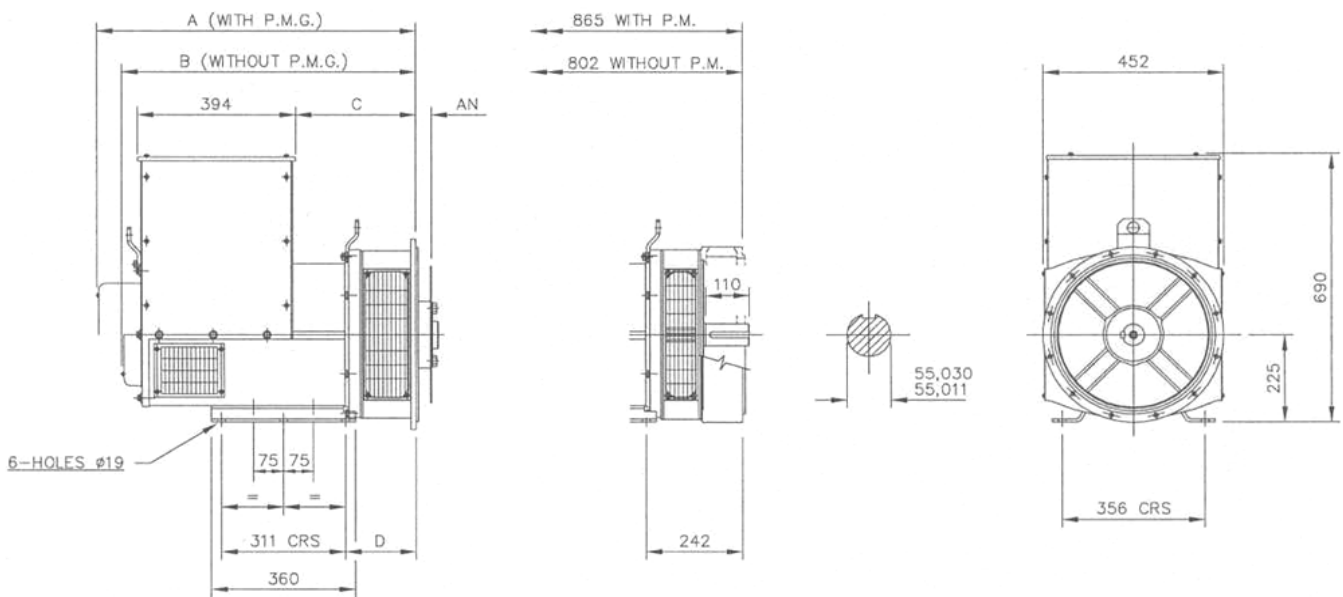

SINGLE BEARING MACHINES ONLY						
ADAPTOR	A	B	C	D	COUPLING DISCS	AN
SAE 1	814,3	751,3	314,3	191,3	SAE 8	61,90
SAE 2	800	737	300	177	SAE 10	53,98
SAE 3	800	737	300	177	SAE 11,5	39,68
SAE 4	800	737	300	177	SAE 14	25,40

STAMFORD

Head Office Address:
Barnack Road, Stamford
Lincolnshire, PE9 2NB
United Kingdom
Tel: +44 (0) 1780 484000
Fax: +44 (0) 1780 484100

www.cumminsgeneratortechnologies.com

Copyright 2010, Cummins Generator Technologies Ltd, All Rights Reserved
Stamford and AvK are registered trade marks of Cummins Generator Technologies Ltd
Cummins and the Cummins logo are registered trade marks of Cummins Inc.

DSE7410/20

AUTO START & AUTO MAINS FAILURE MODULES

FEATURES

The DSE7410 is an Auto Start Control Module and the **DSE7420** is an Auto Mains (Utility) Failure Control Module suitable for a wide variety of single, diesel or gas, gen-set applications.

A sophisticated module monitoring an extensive number of engine parameters, the DSE74xx will announce warnings, shutdown and engine status information on the back-lit LCD screen, illuminated LED, remote PC, audible alarm and via SMS text alerts. The module includes RS232, RS485 & Ethernet ports as well as dedicated terminals for system expansion.

The DSE7400 Series modules are compatible with electronic (CAN) and non-electronic (magnetic pick-up/alternator sensing) engines and offer a comprehensive number of flexible inputs, outputs and extensive engine protections so the system can be easily adapted to meet the most demanding industry paralleling requirements.

The modules can be easily configured using the DSE Configuration Suite Software. Selected front panel editing is also available.

ENVIRONMENTAL TESTING STANDARDS

ELECTRO-MAGNETIC COMPATIBILITY

BS EN 61000-6-2
EMC Generic Immunity Standard for the Industrial Environment
BS EN 61000-6-4
EMC Generic Emission Standard for the Industrial Environment

ELECTRICAL SAFETY

BS EN 60950
Safety of Information Technology Equipment, including Electrical Business Equipment

TEMPERATURE

BS EN 60068-2-1
Ab/Ae Cold Test -30 °C
BS EN 60068-2-2
Bb/Be Dry Heat +70 °C

VIBRATION

BS EN 60068-2-6
Ten sweeps in each of three major axes
5 Hz to 8 Hz @ +/-7.5 mm,
8 Hz to 500 Hz @ 2 gn

HUMIDITY

BS EN 60068-2-30
Db Damp Heat Cyclic 20/55 °C @ 95% RH 48 Hours
BS EN 60068-2-78
Cab Damp Heat Static 40 °C @ 93% RH 48 Hours

SHOCK

BS EN 60068-2-27
Three shocks in each of three major axes
15 gn in 11 ms

DEGREES OF PROTECTION PROVIDED BY ENCLOSURES

BS EN 60529
IP65 - Front of module when installed into the control panel with the supplied sealing gasket.

COMPREHENSIVE FEATURE LIST TO SUIT A WIDE VARIETY OF GEN-SET APPLICATIONS

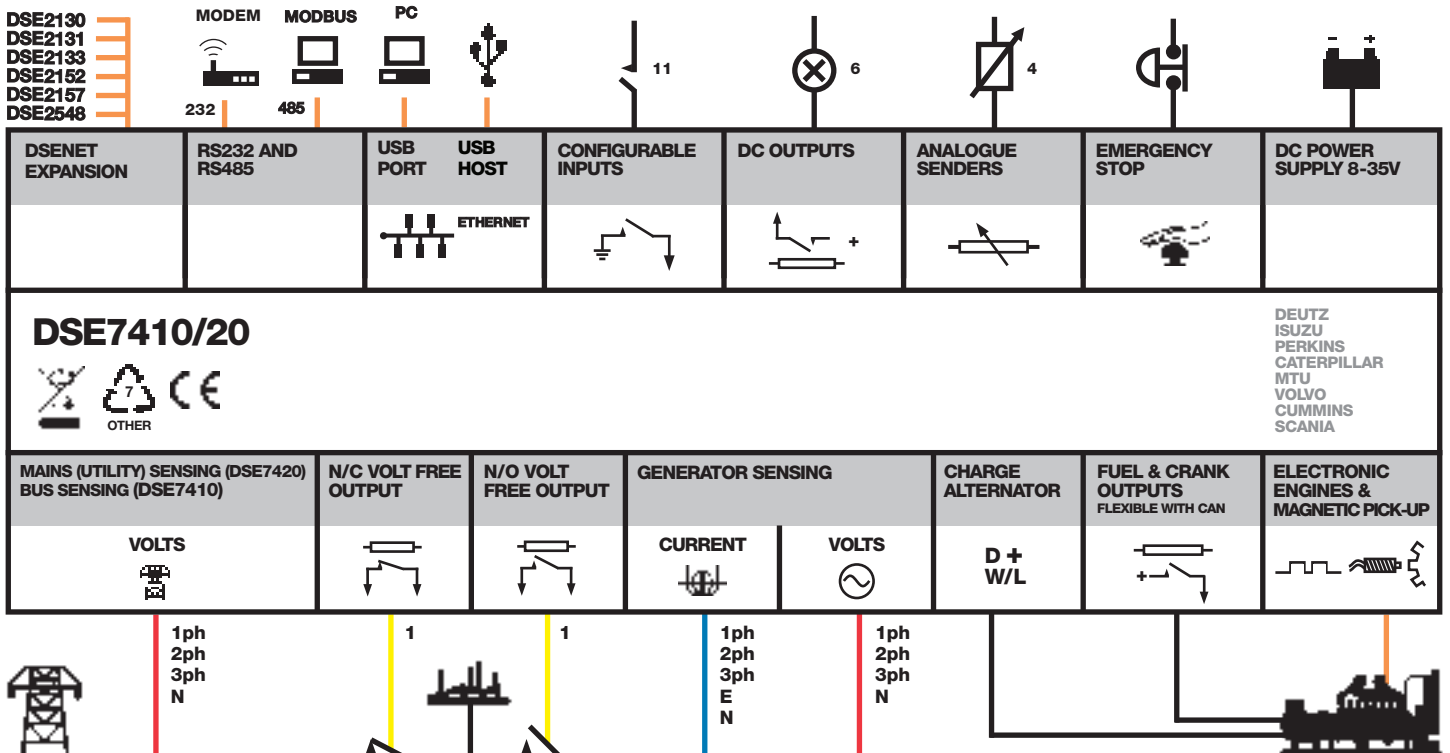

DSE7410/20

AUTO START & AUTO MAINS FAILURE MODULES

FEATURES



DSE7420

DSE7410



KEY FEATURES

- Configurable inputs (11)
- Configurable outputs (8)
- Voltage measurement
- Mains (utility) failure detection
- Dedicated load test button
- kW overload alarms
- Comprehensive electrical protection
- RS232, RS485 & Ethernet remote communications
- Modbus RTU/TCP
- PLC functionality
- Multi event exercise timer
- Back-lit LCD 4-line text display
- Multiple display languages
- Automatic start/Manual start
- Audible alarm
- Fixed and flexible LED indicators
- Event log (250)
- Engine protection
- Fault condition notification to a designated PC
- Front panel mounting
- Protected front panel programming
- Configurable alarms and timers
- Configurable start and stop timers

- Five key menu navigation
- Front panel editing with PIN protection
- 3 configurable maintenance alarms
- CAN and magnetic pick-up/Alt. sensing
- Fuel usage monitor and low fuel alarms
- Charge alternator failure alarm
- Manual speed control (on compatible CAN engines)
- Manual fuel pump control
- "Protections disabled" feature
- Reverse power protection
- Power monitoring (kW h, kV Ar, kV A h, kV Ar h)
- Load switching (load shedding and dummy load outputs)
- Automatic load transfer (DSE7420)
- Unbalanced load protection
- Independent earth fault trip
- Fully configurable via DSE Configuration Suite PC software
- Configurable display languages
- Remote SCADA monitoring via DSE Configuration Suite PC software

- Advanced SMS messaging (additional external modem required)
- Start & stop capability via SMS messaging
- Additional display screens to help with modem diagnostics
- DSENet® expansion
- Integral PLC editor

KEY BENEFITS

- RS232, RS485 & Ethernet can be used at the same time
- DSENet® connection for system expansion
- PLC functionality
- Five step dummy load support
- Five step load shedding support
- High number of inputs and outputs
- Worldwide language support
- Direct USB connection to PC
- Ethernet monitoring
- USB host
- Data logging & trending

RELATED MATERIALS

TITLE

DSE7410 Installation Instructions
DSE7420 Installation Instructions
 DSE74xx Quick Start Guide
 DSE74xx Operator Manual
 DSE74xx PC Configuration Suite Manual

PART NO'S

053-085
 053-088
 057-162
 057-161
 057-160

SPECIFICATION

DC SUPPLY

CONTINUOUS VOLTAGE RATING
 8 V to 35 V Continuous

CRANKING DROPOUTS

Able to survive 0 V for 50 mS, providing supply was at least 10 V before dropout and supply recovers to 5 V. This is achieved without the need for internal batteries

MAXIMUM OPERATING CURRENT

260 mA at 12 V, 130 mA at 24 V

MAXIMUM STANDBY CURRENT

120 mA at 12 V, 65 mA at 24 V

CHARGE FAIL/EXCITATION RANGE

0 V to 35 V

OUTPUTS

OUTPUT A (FUEL)

15 A DC at supply voltage

OUTPUT B (START)

15 A DC at supply voltage

OUTPUTS C & D

8 A AC at 250 V AC (Volt free)

AUXILIARY OUTPUTS E,F,G,H,I & J

2 A DC at supply voltage

GENERATOR

VOLTAGE RANGE

15 V to 333 V AC (L-N)

FREQUENCY RANGE

3.5 Hz to 75 Hz

MAINS (UTILITY) (DSE7420)

VOLTAGE RANGE

15 V to 333 V AC (L-N)

FREQUENCY RANGE

3.5 Hz to 75 Hz

BUS (DSE7410)

VOLTAGE RANGE

15 V to 333 V AC (L-N)

FREQUENCY RANGE

3.5 Hz to 75 Hz

MAGNETIC PICK UP

VOLTAGE RANGE

+/- 0.5 V to 70 V

FREQUENCY RANGE

10,000 Hz (max)

DIMENSIONS

OVERALL

240 mm x 172 mm x 57 mm
 9.4" x 6.8" x 2.2"

PANEL CUTOUT

220 mm x 160 mm
 8.7" x 6.3"

MAXIMUM PANEL THICKNESS

8 mm
 0.3"

STORAGE TEMPERATURE RANGE

-40 °C to +85 °C

DEEP SEA ELECTRONICS PLC UK

Highfield House, Hunmanby Industrial Estate, Hunmanby YO14 0PH
TELEPHONE +44 (0) 1723 890099 **FACSIMILE** +44 (0) 1723 893303
EMAIL sales@deepseapl.com **WEBSITE** www.deepseapl.com

DEEP SEA ELECTRONICS INC USA

3230 Williams Avenue, Rockford, IL 61101-2668 USA
TELEPHONE +1 (815) 316 8706 **FACSIMILE** +1 (815) 316 8708
EMAIL sales@deepseausa.com **WEBSITE** www.deepseausa.com

Tmax-Molded Case Circuit Breakers

T1 100A Frame

AC Circuit Breakers & Switches

DC Circuit Breakers & Switches

1, 3 and 4 Poles

Higher performances in less space

Field Installable Accessories



Dimensions 3P Fixed Version 5.12H x 3.00W x 2.76D

Compliance with Standards

UL 489

CSA C22.2 No.5.1

IEC 60947-2

Standards

EC directive:

– “Low Voltage Directives” (LVD) no. 73/23 EEC

– “Electromagnetic Compatibility Directive” (EMC) no.89/336 EEC

The ABB Quality System complies with the international ISO 9001 - 2000 Standard (model for quality assurance in design, development, construction, and installation and service) and with the equivalent European EN ISO 9001 and Italian UNI EN ISO 9001 Standards

Interrupting ratings (RMS sym. kAmps)

	T1	
Continuous Current Rating	100A	100A
Number of Poles	1	3-4
	B	N
AC		
240V		50
277V	18	
347V	14	
480V		22
600Y/347V		10
DC		
250V 2 poles in series		25
500V 3 poles in series		25

Please Note: 15 A 1P 10Kaic @ 347Vac, 3p 14Kaic @ 480Y/277Vac, 3p 35Kaic @ 240Vac



Company Quality Systems and Environmental Systems

The new Tmax series has a hologram on the front, obtained using special anti-imitation techniques, which guarantees the quality and that the circuit breaker is an original ABB product.

Attention to protection of the environment and to health and safety in the work place is another priority commitment for ABB and, as confirmation of this, the company environmental management system has been certified by RINA in 1997, in conformity with the international ISO 14001 Standard. This certification has been integrated in 1999 with the Management System for Health and Safety in the workplace, according to OHSAS 18001 (British Standards), obtaining one of the first certification of integrated management System, QES (Quality, Environment,

Safety) issued by RINA. ABB - the first industry in the electro-mechanical section in Italy to obtain this recognition - thanks to a revision of the production process with an eye to ecology has been able to reduce the consumption of raw materials and waste from processing by 20%. ABB's commitment to safeguarding the environment is also shown in a concrete way by the Life Cycle Assessments of its products carried out directly by the ABB Research and Development in collaboration with the ABB Research Center. Selection of materials, processes and packing materials is made optimizing the true environmental impact of the product, also foreseeing the possibility of its being recycled.

Mounting

Fixed

Connections

Pressure-type terminals for bare copper cables

Trip Unit

TMF thermo magnetic trip units, with fixed thermal and magnetic threshold ($I_3 = 10 \times I_n$);

Weight (lbs)	2.34
---------------------	------

Auxiliary Devices for Indication and Control

- Auxiliary contacts - AUX
- Undervoltage release - UVR
- Shunt trip - SOR
- Terminal covers
- Flange handle mechanism
- Direct rotary handle - RHD
- Through the door rotary handle
- Solenoid operator
- Key lock - KLF
- Early auxiliary contact - AVE
- Front terminal for copper cable - FC CU
- Front extended terminal - EF
- Phase separators
- Residual current release (IEC Only)
- Mechanical interlock



ABB Inc.

1206 Hatton Road
Wichita Falls, TX 76302
For more information and
the location of your local
field office please go to
www.abb-control.com

Tmax-Molded Case Circuit Breakers

T3 225A Frame

AC Circuit Breakers and Switches

DC Circuit Breakers and Switches

3 and 4 Pole

Motor Circuit Protectors

Higher Performances in Less Space

Field Installable Accessories



Dimensions 3P Fixed Version 5.9H x 4.13W x 2.76D

Compliance with Standards

UL 489

CSA C22.2 No.5.1

IEC 60947-2

Standards

EC directive:

- "Low Voltage Directives" (LVD) no. 73/23 EEC

- "Electromagnetic Compatibility Directive" (EMC) no.89/336 EEC

The ABB Quality System complies with the international ISO 9001 - 2000 Standard (model for quality assurance in design, development, construction, and installation and service) and with the equivalent European EN ISO 9001 and Italian UNI EN ISO 9001 Standards

Interrupting ratings (RMS sym. kAmps)		T3	
Continuous Current Rating		225A	
Number of Poles		3-4	
		N	S
AC			
	240V	50	65
	480V	25	35
	600Y / 347V	10	10
DC			
	250V 2 poles in series	25	35
	500V 3 poles in series	25	35



Company Quality Systems and Environmental Systems

The new Tmax series has a hologram on the front, obtained using special anti-imitation techniques, which guarantees the quality and that the circuit breaker is an original ABB product.

Attention to protection of the environment and to health and safety in the work place is another priority commitment for ABB and, as confirmation of this, the company environmental management system has been certified by RINA in 1997, in conformity with the international ISO 14001 Standard. This certification has been integrated in 1999 with the Management System for Health and Safety in the workplace, according to OHSAS 18001 (British Standards), obtaining one of the first certification of integrated management System, QES (Quality, Environment,

Safety) issued by RINA. ABB - the first industry in the electro-mechanical section in Italy to obtain this recognition - thanks to a revision of the production process with an eye to ecology has been able to reduce the consumption of raw materials and waste from processing by 20%. ABB's commitment to safeguarding the environment is also shown in a concrete way by the Life Cycle Assessments of its products carried out directly by the ABB Research and Development in collaboration with the ABB Research Center. Selection of materials, processes and packing materials is made optimizing the true environmental impact of the product, also foreseeing the possibility of its being recycled.

Mounting

Fixed
Plug-in

Connections

Busbar connection or compression lugs
Pressure-type terminals for bare cables
Rear connections

Trip Unit

TMF thermo magnetic trip units, with fixed thermal and magnetic threshold ($I_3 = 10 \times I_n$);

Weight (lbs)	5.45
---------------------	------

Auxiliary Devices for Indication and Control

- Auxiliary contacts - AUX
- Undervoltage release - UVR
- Shunt trip - SOR
- Terminal covers
- Front for lever operating mechanism - FLD
- Direct rotary handle - RHD
- Solenoid operator
- Key lock - KLF
- Early auxiliary contact - AUE
- Transmitted rotary handle - RHE
- Front terminal for copper cable - FC Cu
- Front extended terminal - EF
- Front terminal for copper-aluminum - FC CuAl
- Front extended spread terminal - ES
- Distribution lugs
- Rear orientated terminal - R
- Phase separators
- Residual current release (IEC Only)



ABB Inc.

1206 Hatton Road
Wichita Falls, TX 76302
For more information and
the location of your local
field office please go to
www.abb-control.com

Tmax-Molded Case Circuit Breakers

T4 250A Frame

AC Circuit Breakers and Switches

DC Circuit Breakers and Switches

3 and 4 Pole

Motor Circuit Protectors

Higher Performances in Less Space

Field Installable Accessories and Trip Units



Dimensions 3P Fixed Version 8.07H x 4.13W x 4.07D

Compliance with Standards

UL 489

CSA C22.2 No.5.1

IEC 60947-2

Standards

EC directive:

- "Low Voltage Directives" (LVD) no. 73/23 EEC

- "Electromagnetic Compatibility Directive" (EMC) no.89/336 EEC

The ABB Quality System complies with the international ISO 9001 - 2000 Standard (model for quality assurance in design, development, construction, and installation and service) and with the equivalent European EN ISO 9001 and Italian UNI EN ISO 9001 Standards

Interrupting ratings (RMS sym. kAmps)

T4

Continuous Current Rating

250A

Number of Poles

3-4

		N	S	H	L	V
AC						
	240V	65	100	150	200	200
	480V	25	35	65	100	150
	600V	18	25	35	65	100
DC*						
	500V 2 poles in series	25	35	50	65	100
	600V 3 poles in series	16	25	35	50	65

*Thermo Magnetic Trip Only

Company Quality Systems and Environmental Systems

The new Tmax series has a hologram on the front, obtained using special anti-imitation techniques, which guarantees the quality and that the circuit breaker is an original ABB product.

Attention to protection of the environment and to health and safety in the work place is another priority commitment for ABB and, as confirmation of this, the company environmental management system has been certified by RINA in 1997, in conformity with the international ISO 14001 Standard. This certification has been integrated in 1999 with the Management System for Health and Safety in the workplace, according to OHSAS 18001 (British Standards), obtaining one of the first certification of integrated management System, QES (Quality, Environment,

Safety) issued by RINA. ABB - the first industry in the electro-mechanical section in Italy to obtain this recognition - thanks to a revision of the production process with an eye to ecology has been able to reduce the consumption of raw materials and waste from processing by 20%. ABB's commitment to safeguarding the environment is also shown in a concrete way by the Life Cycle Assessments of its products carried out directly by the ABB Research and Development in collaboration with the ABB Research Center. Selection of materials, processes and packing materials is made optimizing the true environmental impact of the product, also foreseeing the possibility of its being recycled.

Mounting

Fixed
Plug-in
Drawout

Connections

Busbar connection or compression lugs
Pressure-type terminals for bare cables
Rear connections

Trip Unit

TMF thermo magnetic trip units, with fixed thermal and magnetic threshold ($I_3 = 10 \times I_n$);

TMD (up to 50 A) thermo magnetic trip units with adjustable thermal threshold ($I_1 = 0.7 \dots 1 \times I_n$) and fixed magnetic threshold ($I_3 = 10 \times I_n$).

TMA thermo magnetic trip units, with adjustable thermal threshold ($I_1 = 0.7 \dots 1 \times I_n$) and adjustable magnetic threshold ($I_3 = 5 \dots 10 \times I_n$).

PR221DS, PR222DS/P and PR222DS/PD-A electronic trip unit

Weight (lbs)	6.18
---------------------	------

Auxiliary Devices for Indication and Control

- Auxiliary contacts - AUX
- Undervoltage release - UVR
- Shunt trip - SOR
- Terminal covers
- Front for lever operating mechanism - FLD
- Direct rotary handle - RHD
- Stored energy motor operator - MOE
- Key lock - KLF
- Early auxiliary contact - AUE
- Transmitted rotary handle - RHE
- Front terminal for copper cable - FC Cu
- Front extended terminal - EF
- Front terminal for copper-aluminum - FC CuAl
- Front extended spread terminal - ES
- Distribution lugs
- Rear orientated terminal - R
- Phase separators
- Residual current release (IEC Only)



ABB Inc.

1206 Hatton Road
Wichita Falls, TX 76302
For more information and
the location of your local
field office please go to
www.abb-control.com

Tmax-Molded Case Circuit Breakers

T5 400A and 600A Frame

AC Circuit Breakers and Switches

DC Circuit Breakers and Switches (400A Only)

3 and 4 Pole

Motor Circuit Protectors

Higher Performances in Less Space

Field Installable Accessories and Trip Units



Dimensions 3P Fixed Version 8.07H x 5.51W x 4.07D

Compliance with Standards

UL 489

CSA C22.2 No.5.1

IEC 60947-2

Standards

EC directive:

- "Low Voltage Directives" (LVD) no. 73/23 EEC

- "Electromagnetic Compatibility Directive" (EMC) no.89/336 EEC

The ABB Quality System complies with the international ISO 9001 - 2000 Standard (model for quality assurance in design, development, construction, and installation and service) and with the equivalent European EN ISO 9001 and Italian UNI EN ISO 9001 Standards

Interrupting ratings (RMS sym. kAmps)

T5

Continuous Current Rating

400-600A

Number of Poles

3-4

		N	S	H	L	V
AC						
240V		65	100	150	200	200
480V		25	35	65	100	150
600V		18	25	35	65	100
DC* (400 A only)						
500V	2 poles in series	25	35	50	65	100
600V	3 poles in series	16	25	35	50	65

*Thermo Magnetic Trip Only



Company Quality Systems and Environmental Systems

The new Tmax series has a hologram on the front, obtained using special anti-imitation techniques, which guarantees the quality and that the circuit breaker is an original ABB product.

Attention to protection of the environment and to health and safety in the work place is another priority commitment for ABB and, as confirmation of this, the company environmental management system has been certified by RINA in 1997, in conformity with the international ISO 14001 Standard. This certification has been integrated in 1999 with the Management System for Health and Safety in the workplace, according to OHSAS 18001 (British Standards), obtaining one of the first certification of integrated management System, QES (Quality, Environment,

Safety) issued by RINA. ABB - the first industry in the electro-mechanical section in Italy to obtain this recognition - thanks to a revision of the production process with an eye to ecology has been able to reduce the consumption of raw materials and waste from processing by 20%. ABB's commitment to safeguarding the environment is also shown in a concrete way by the Life Cycle Assessments of its products carried out directly by the ABB Research and Development in collaboration with the ABB Research Center. Selection of materials, processes and packing materials is made optimizing the true environmental impact of the product, also foreseeing the possibility of its being recycled.

Mounting

Fixed
Plug-in
Drawout

Connections

Busbar connection or compression lugs
Pressure-type terminals for bare cables
Rear connections

Trip Unit

TMA thermo magnetic trip units, with adjustable thermal threshold ($I_1 = 0.7 \dots 1 \times I_n$) and adjustable magnetic threshold ($I_3 = 5 \dots 10 \times I_n$).

PR221DS, PR222DS/P and PR222DS/PD-A electronic trip unit

Weight (lbs)	8.55
---------------------	------

Auxiliary Devices for Indication and Control

- Auxiliary contacts - AUX
- Undervoltage release - UVR
- Shunt trip - SOR
- Terminal covers
- Front for lever operating mechanism - FLD
- Direct rotary handle - RHD
- Stored energy motor operator - MOE
- Key lock - KLF
- Early auxiliary contact - AUE
- Transmitted rotary handle - RHE
- Front terminal for copper cable - FC Cu
- Front extended terminal - EF
- Front terminal for copper-aluminum - FC CuAl
- Front extended spread terminal - ES
- Distribution lugs
- Rear orientated terminal - R
- Phase separators
- Residual current release (IEC Only)



ABB Inc.

1206 Hatton Road
Wichita Falls, TX 76302
For more information and
the location of your local
field office please go to
www.abb-control.com

GUEST® Genset Chargers



Guest chargers are proven performers in genset applications. For specific application information, or if you are developing a new product, be sure to consult with the Guest applications engineering team to ensure the correct charger is specified.

Genset Chargers

MODEL	TOTAL AMPS	OUT-PUTS	AMPS PER OUTPUT	BATTERY SYSTEM	INPUT VOLTAGE	AC	DC	DIMENSIONS	WT. (LBS)	AGENCY LISTING
2602A-12	2	1	2	12V	100 - 130 50/60Hz	6' w/ Connect- Charge plug	4' w/ ring terminals	2.9" x 5.1" x 1.5"	2	UL
2602A-12-B (bulk)										
2605A-1-24RT-01 (bulk pack only) (1)	5	1	5	24V	100 - 130 50/60Hz	6' SJT 18-3 w/ Connect- Charge plug	6' SJT 18-3 w/ ring terminals	7.4" x 6.3" x 2.4"	4.5	UL
2608A-B-01 (bulk pack only) (1)	6	1	6	12V	100 - 130 50/60Hz	6' cable w/ molded plug rated -40 to 105C	4' w/ ring terminals rated -40 to 105C	3.5" x 6.4" x 2.3"	4	UL
2610A	10	2	5/5	12V+12V	100 - 130 50/60Hz	Studs	Studs	5.5" x 7.8" x 2.4"	5.6	-
2610A-B (bulk)										UL (bulk only)

(1) 2-stage charging



Individual agency listings as shown in product chart.

Plastic Magna Seal Air Cleaners

Internal or External Evacuator Valve
High Strength Polymer
Working Temp -40c to +80c (-40F to 176F)
Design Compatibility with other Manufacturers
Industry Standard elements
Can be Mounted Vertical or Horizontal

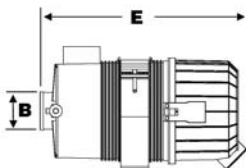
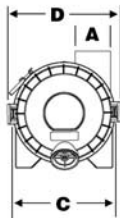

**Type 1
Straight Outlet**

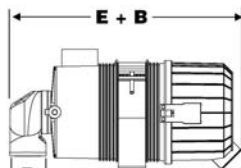

**Type 2
90° Outlet**

Air Cleaner Assembly

Model Number	Part Number	Type	Initial Restriction						A		B		C		D		E	
			6" H2O CFM	6" H2O M3m	8" H2O CFM	8" H2O M3m	10" H2O CFM	10" H2O M3m	OD Inlet inch	OD Inlet mm	OD Outlet inch	OD Outlet mm	inch	mm	inch	mm	inch	mm
2s-FW-E1	68110	1	75	2.1	90	2.5	105	3.0	2.00	51	1.75	45	4.8	122	6.14	156	8.98	228
2s-FW-E2	68111	1	65	1.8	75	2.1	85	2.4	2.00	51	1.75	45	4.80	122	6.14	156	8.98	228
2s-FW-E1-90	68103	2	63	1.7	73	2.0	82	2.3	2.00	51	1.75	45	4.80	122	6.14	156	10.43	265
2s-FW-E2-90	68107	2	53	1.5	63	1.8	71	2.0	2.00	51	1.75	45	4.80	122	6.14	156	10.43	265
2-FW-E1	68120	1	100	2.8	115	3.3	130	3.7	2.00	51	2.00	51	5.75	146	7.09	180	13.39	340
2-FW-E2	68130	1	90	2.5	105	3.0	115	3.3	2.00	51	2.00	51	5.75	146	7.09	180	13.39	340
2-FW-E1-90	68116	2	88	2.4	102	2.9	113	3.2	2.00	51	2.00	51	5.75	146	7.09	180	14.96	380
2-FW-E2-90	68127	2	77	2.2	92	2.6	103	2.9	2.00	51	2.00	51	5.75	146	7.09	180	14.96	380
2.5-FW-E1	68132	1	150	4.2	175	5.0	195	5.5	2.50	63.5	2.50	63.5	6.89	175	8.15	207	14.13	359
2.5-FW-E2	68133	1	145	4.1	165	4.7	185	5.2	2.50	63.5	2.50	63.5	6.89	175	8.15	207	14.13	359
2.5-FW-E1-90	68131	2	134	3.8	156	4.4	175	5.0	2.50	63.5	2.50	63.5	6.89	175	8.15	207	16.22	412
2.5-FW-E2-90	68134	2	127	3.6	148	4.2	168	4.7	2.50	63.5	2.50	63.5	6.89	175	8.15	207	16.22	412
3-FW-E1	68140	1	160	4.5	190	5.4	210	5.9	3.00	76	3.00	76	7.24	184	8.58	218	14.57	370
3-FW-E2	68150	1	150	4.2	170	4.8	190	5.4	3.00	76	3.00	76	7.24	184	8.58	218	14.57	370
3-FW-E1-90	68140-2	2	154	4.4	181	5.1	196	5.6	3.00	76	3.00	76	7.24	184	8.58	218	17.80	452
3-FW-E2-90	68150-2	2	138	4.0	162	4.6	182	5.2	3.00	76	3.00	76	7.24	184	8.58	218	17.80	452
3.75-FW-E1	68160	1	250	7.1	290	5.4	325	9.2	3.75	95	3.50	89	8.35	212	9.72	247	15.63	397
3.75-FW-E2	68170	1	225	6.4	260	7.4	280	7.9	3.75	95	3.50	89	8.35	212	9.72	247	15.63	397
3.75-FW-E1-90	68157	2	212	6.0	250	7.1	277	7.8	3.75	95	3.50	89	8.35	212	9.72	247	18.5	470
3.75-FW-E2-90	68167	2	188	5.3	220	6.2	250	7.1	3.75	95	3.50	89	8.35	212	9.72	247	18.5	470
4.5-FW-E1	68175	1	375	10.6	425	12.0	475	13.5	4.50	114	4.00	102	10.60	268	11.9	302	19.13	486
4.5-FW-E2	68175-1	1	325	9.2	375	10.6	425	12.0	4.50	114	4.00	102	10.60	268	11.9	302	19.13	486
6-FW-E1	68178	1	600	17.0	685	19.4	770	21.8	6.00	152	5.00	127	12.20	309	13.54	344	22.00	560
6-FW-E2	68179	1	500	14.2	565	16.0	630	17.8	6.00	152	5.00	127	12.20	309	13.54	344	22.00	560
7-FW-E1	68182	1	800	22.7	910	25.8	1060	30.0	7.00	178	6.00	152	15.50	394	16.80	427	21.50	545
7-FW-E2	68185	1	710	20.1	830	23.5	960	27.2	7.00	178	6.00	152	15.50	394	16.80	427	21.50	545

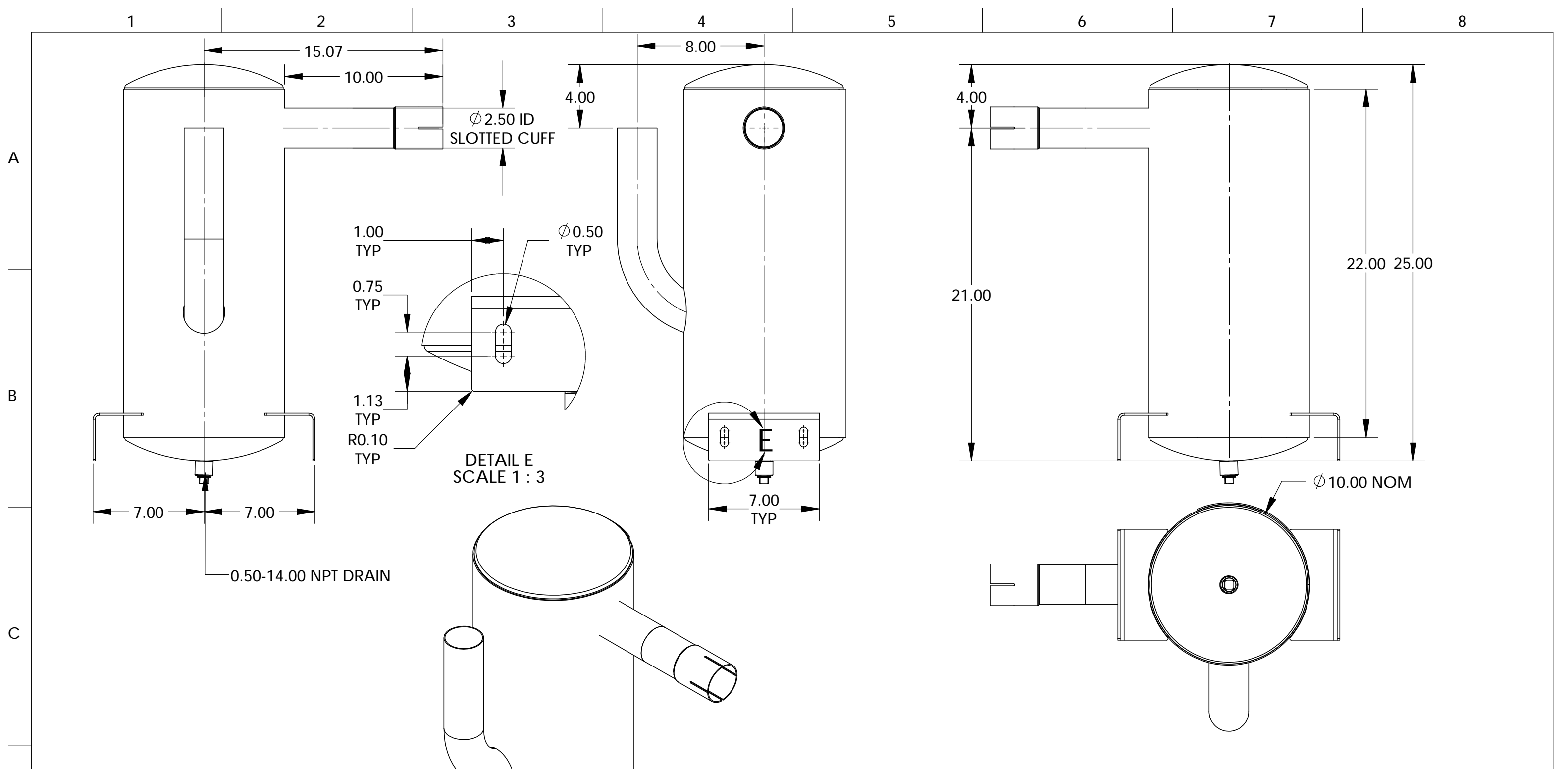

ENGINE INFORMATION	SILENCER INFORMATION	DRAWN BY CB	DATE 09/15/2017	
ENGINE MAKE GM	RESONATOR FREQUENCY ---	CHECKED BY CB	DATE 09/15/2017	
ENGINE MODEL 5.7L	RESONATOR ALPHA ---	ENGINEERING CB	DATE	DESCRIPTION SIL: COMP CRIT CS S-E
DISPLACEMENT 350	SILENCER Km ---	MANUFACTURING CB	DATE	2.50-2.50 Ø10.00
EXHAUST FLOW 687	SILENCER IL ---	TOLERANCES UNLESS OTHERWISE SPECIFIED .X = ±0.25 ALL ANGLES .XX = ±0.125 ±1° .XXX = ±0.0625 .XXXX = ±0.03125	WEIGHT (LBS) 37	CONSTRUCTION MATERIAL CS
EXHAUST TEMPERATURE 1250	TOLERANCES DO NOT APPLY TO GAGE THICKNESS OR COMMERCIAL FEATURES	THIRD ANGLE PROJECTION	SHEET 3 OF 3	FINISH HIGH TEMP BLACK PAINT
MAX BACK PRESSURE 40.8				PART NUMBER 500-008650
RAW SOUND PRESSURE ---				SCALE (DO NOT SCALE) SHEET SIZE 1:6 B

REV.	BY	DATE	DESCRIPTION	ECO
01	CB	09/15/2017	RELEASED FOR CUSTOMER APPROVAL	---

CUSTOMER

CUSTOMER P/N

OUTLINE DIMENSIONS FOR 41 THRU 62 KW OPEN GEN-SET

