



GILLETTE GENERATORS

LIQUID COOLED DIESEL ENGINE GENERATOR SET

Model	HZ	STANDBY 120°C RISE
		350
SPVD-3500-60 HERTZ	60	

60 HZ MODEL
SPVD-3500



All generator sets are USA prototype built and thoroughly tested. Production models are USA factory built and 100% load tested.



UL2200, UL1446, UL508, UL142, UL498



NFPA 110, 99, 70, 37

All generator sets meet NFPA-110 Level 1, when equipped with the necessary accessories and installed per NFPA standards.



NEC 700, 701, 702, 708



NEMA ICS10, MG1, ICS6, AB1



ANSI C62.41, 27, 59, 32, 480, 40Q, 81U, 360-05



ASCE 7-05 & 7-10

All generator sets meet 180 MPH rating.



EPA 40CFR Part 60, 1048, 1054, 1065, 1068

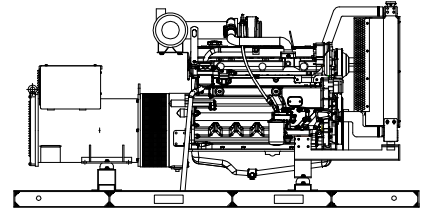

“OPEN” GEN-SET

There is no enclosure, so gen-set must be placed within a weather protected area, uninhabited by humans or animals, with proper ventilation. Silencer not supplied, as installation requirements are not known. However, this item is available as optional equipment.

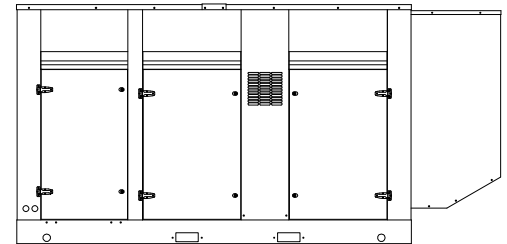

“LEVEL 2” HOUSED GEN-SET

Full aluminum weather protection and superior sound attenuation for specific low noise applications. Critical grade muffler is standard.

GENERATOR RATINGS

GENERATOR MODEL	VOLTAGE		PH	HZ	130°C RISE STANDBY RATING		POWER LEAD CONNECTIONS
	L-N	L-L			KW/KVA	AMP	
SPVD-3500-3-2	120	208	3	60	350/438	1200	12 LEAD LOW WYE
SPVD-3500-3-3	120	240	3	60	350/438	1053	12 LEAD HIGH DELTA
SPVD-3500-3-4	277	480	3	60	350/438	526	12 LEAD HIGH WYE
SPVD-3500-3-5	127	220	3	60	350/438	1150	12 LEAD LOW WYE
SPVD-3500-3-16	346	600	3	60	350/438	421	4 LEAD WYE DEDICATED

RATINGS: All single phase gen-sets are dedicated 4 lead windings, rated at unity (1.0) power factor. All three phase gen-sets are 12 lead windings, rated at .8 power factor. 120° C “STANDBY RATINGS” are strictly for gen-sets that are used for back-up emergency power to a failed normal utility power source. This standby rating allows varying loads, with no overload capability, for the entire duration of utility power outage. All gen-set power ratings are based on temperature rise measured by resistance method as defined by MIL-STD 705C and IEEE STD 115, METHOD 6.4.4. All generators have class H (180°C) insulation system on both rotor and stator windings. All factory tests and KW/KVA charts shown above are based 120°C (standby) R/R winding temperature, within a maximum 40°C ambient condition. Generators operated at standby power ratings must not exceed the temperature rise limitation for class H insulation system, as specified in NEMA MG1-22.40. Specifications & ratings are subject to change without prior notice.

APPLICATION & ENGINEERING DATA FOR MODEL SPVD-3500-60 HZ

GENERATOR SPECIFICATIONS

Manufacturer.....Stamford Electric Generators
Model & Type..... S4L1D-F311, 4 Pole, 12 Lead, Three Phase
.....S4L1D-E311, 4 Pole, 12 Lead, 480V, Three Phase
.....HCI434E-17, 4 Pole, 4 Lead, 600V, Three Phase
Exciter.....Brushless, shunt excited
Voltage Regulator.....Solid State, HZ/Volts
Voltage Regulation.....½%, No load to full load
Frequency.....60 HZ
Frequency Regulation.....± ½% (1/2 cycle, no load to full load)
Unbalanced Load Capability.....100% of standby amps
One Step Load Acceptance.....100% of nameplate rating
Total Stator and Load Insulation.....Class H, 180°C
Temperature Rise.....120°C R/R, standby rating @ 40°C amb.
3 Ø Motor Starting @ 30% Voltage Dip (208-240V).....750 kVA
3 Ø Motor Starting @ 30% Voltage Dip (480V).....970 kVA
3 Ø Motor Starting @ 30% Voltage Dip (600V).....1140 kVA
Bearing.....1, Pre-lubed and sealed
Coupling.....Direct flexible disc.
Total Harmonic Distortion.....Max 3½% (MIL-STD705B)
Telephone Interference Factor.....Max 50 (NEMA MG1-22)
Deviation Factor.....Max 5% (MIL-STD 405B)
Alternator.....Self ventilating and drip-proof
Ltd. Warranty Period.....24 Months from start-up date or
.....1000 hours use, first to occur.

GENERATOR FEATURES

- World Renown Stamford Electric Generator having UL-1446 certification.
- Full generator protection with **Basler DGC-2020** controller, having UL-508 certification.
- Automatic voltage regulator with over-excitation, under-frequency compensation, under-speed protection, and EMI filtering. Entire solid-state board is encapsulated for moisture protection.
- Generator power ratings are based on temperature rise, measured by resistance method, as defined in MIL-STD 705C and IEEE STD 115, Method 6.4.4.
- Power ratings will not exceed temperature rise limitation for class H insulation as per NEMA MG1-22.40.
- Insulation resistance to ground, exceeds 1.5 meg-ohm.
- Stator receives 2000 V. hi-potential test on main windings, and rotor windings receive a 1500 V. hi-potential test, as per MIL-STD 705B.
- Full amortisseur windings with UL-1446 certification.
- Complete engine-generator torsional acceptance, confirmed during initial prototype testing.
- Full load testing on all engine-generator sets, before shipping.

ENGINE SPECIFICATIONS AND APPLICATIONS DATA

ENGINE

Manufacturer.....VOLVO-PENTA
Model and Type.....TAD1352GE, 4 cycle, liquid Cooled
Aspiration.....Turbo After Cooler, Air to Air
Charged Air Cooled System.....Air to Air
Cylinder Arrangement.....6 Cylinders, In-Line
Displacement Cu. In. (Liters).....780(12.8)
Bore & Stroke in (Cm).....5.16 x 6.22 (13.1 x 15.8)
Compression Ratio.....18:1
Main Bearings.....Tin Overlay with Babbit Backing
Cylinder Head.....Cast Iron with overhead Cam
Pistons.....Aluminum Alloy with Graphite Coating
Crankshaft.....Induction Hardened, Heat Treated Forged
Valves.....Heat Treated and Hardened Exhaust Valve
Governor.....Electronic, EMS 2.2
Frequency Regulation.....± 1/4%
Air Cleaner.....Dry, Replaceable Cartridge
Engine Speed.....1800 rpm
Max Power, bhp (kwm) Standby.....537 (395)
BMEP: psi (MPa) Standby.....299 (2.1)
Ltd. Warranty Period.....2 Year or 1000 hrs, first to occur

FUEL SYSTEM

Type.....Diesel Fuel Oil (ASTM No. 2-D)
Combustion System.....Direct Injection
Fuel Injection Pump.....Electronic, Delphi E3
24 VDC Coolant heaters.....Optional Equipment
Fuel Filter.....Yes with Water Separator

FUEL CONSUMPTION

GAL/HR (LITER/HR)	STANDBY
100% LOAD	25.5 (96.5)
75% LOAD	19.3 (73.1)
50% LOAD	13.2 (50.0)

OIL SYSTEM

Type.....Full Pressure
Oil Pan Capacity qt. (L).....31.6 (29.9)
Oil Pan Cap. W/ filter qt. (L).....38 (35.9)
Oil Filter.....3, Replaceable Cartridge type

ELECTRICAL SYSTEM

Ignition System.....Electronic
Eng. Alternator/Starter: 24 VDC, negative ground, 80 amp/hr.
Recommended battery to -18°C (0° F):(2) 12 VDC, BCI# 27,
Max. Dimensions: 12”lg x 6 3/4” wi x 9” hi, with standard round posts. Min output 700 CCA. Battery tray (max. dim. at 12”lg x 7”wi). This model has (2) battery trays, (2) hold down straps, (2) sets of battery cables, and (1) battery charger. Installation of (2) 12VDC starting batteries connected in series for 24VDC output is required, with possible higher AMP/HR rating, as described above, if the normal environment temperature averages -13° F (-25°C) or cooler.

CERTIFICATIONS

All engines are EPA emissions certified. All emergency stationary diesel engines are Tier III compliant.

APPLICATION & ENGINEERING DATA FOR MODEL SPVD-3500-60 HZ

COOLING SYSTEM

Type of System Air to Air, Charged Air Cooler
 Coolant PumpPre-lubricated, self-sealing
 Cooling Fan TypePusher
 Fan Diameter inches (cm).....35.1 (89)
 Fan drive ratio..... 0.99:1
 Ambient Capacity of Radiator °F (°C)..... 131 (55)
 Engine Jacket Coolant Capacity gal. (L).....5.28 (20)
 Radiator Coolant Capacity gal. (L) 11.7 (44)
 Water Pump Capacity gpm (L/min).....87.0 (329)
 Heat Reject Coolant: Btu/min10,066
 Air to Air Heat Reject, BTU/min.4,948
 Heat Radiated to Ambient, BTU/min2,988
 Low Radiator Coolant Level Shutdown.....Standard
 Note: Coolant temp. shut-down switch setting at 228°F (109°C) with 50/50 (water/antifreeze) mix.

COOLING AIR REQUIREMENTS

Combustion Air cfm (m³/min)918 (26.0)
 Max Air Intake Restrictions:
 Clean Air Cleaner, KPA (psi) 5 (1.5)
 Radiator Cooling Air, SCFM (m³/min).....16,325 (462)

EXHAUST SYSTEM

Exhaust Outlet Size.....6"
 Max. Back Pressure in KPA (in. H2O).....10 (40)
 Exhaust Flow, at rated KW, CFM (m³/min)..... 2,391 (68)
 Exhaust Temp, (Stack) °F (°C)995 (535)

SOUND LEVELS MEASURED IN dB(A)

	Open Set	Level 2 Encl.
Level 2, Critical Silencer	90	80
Level 3, Hospital Silencer.....		75

Note: Open sets (no enclosure) have optional silencer system choices due to unknown job-site applications. Level 2 enclosure has installed critical silencer with upgrade to Level 3 hospital silencer. Sound tests are averaged from several test points and taken at 23 ft. (7 m) from source of noise at normal operation.

DERATE GENERATOR FOR ALTITUDE

3% per 1000 ft.(305 meters) above 3000 ft. (914 meters) from sea level.

DERATE GENERATOR FOR TEMPERATURE

2% per 10°F (12°C) above 104°F (40°C)

DIMENSIONS AND WEIGHTS

	Open Set	Level 2 Enclosure
Length in (cm).....	132 (335)	174 (442)
Width in (cm).....	52 (132)	52 (132)
Height in (cm).....	65 (165)	80 (203)
Net Weight lbs (kg).....	6802 (3085)	8209 (3724)
Ship Weight lbs (kg).....	7103 (3222)	8574 (3889)

BASLER DGC-2020 DIGITAL MICROPROCESSOR CONTROLLER



Basler DGC-2020

The “2020” controller is a highly advanced integrated gen-set control system for single gen-set applications. This controller includes a backlit LCD display which continuously displays the status of the engine and generator at all times.

Basler “DGC-2020” includes: Generator metering (including three phase) • Engine – Generator protections including IEEE-[27] under voltage, [32] power, [40] loss of excitation, [59] over voltage, [81] over and under frequency, Exercise timer • SAE J1939 engine ECU communications • Expansion capabilities for both inputs and outputs with expansion • Remote communications through RS-485 to Basler’s RDP110 remote Display panel • (16) programmable contact inputs • (15) programmable contact outputs- (3) for up to 30AmpDC and (12) for up to 2 Amp DC • Illuminated Text Display • Front panel menu scroll buttons • Front panel operation mode buttons for STOP, RUN and AUTO • Alarm Silence and Lamp Test buttons

This controller includes expansion features including, RS485 (using MODBUS), direct USB connection with PC, expansion optioned using BESTCOMSPPlus for remote annunciation and remote relay interfacing for a distance of up to 3300FT. The controller software is freely downloadable from the internet and allows monitoring with direct USB cable, LAN, or by internet via the built in web interface.



Further expansion is available by adding the optional RDP-110 remote display panel module. This featured device will allow Four programmable LEDs (2) alarms and (2) pre-alarms • (17) alarms and pre-alarms displayed from Basler controller • audible alarm horn • lamp test and alarm silence buttons • RD100 local power supply inputs of either 12vdc or 24vdc • connects through Basler controller through RS-485 communications protocol • conduit box included for (2) mounting configurations- either surface mount or semi-flush mounting.

STANDARD FEATURES FOR MODEL SPVD-3500-60 HZ

STANDARD FEATURES

CONTROL PANEL:

Basler DGC-2020 digital microprocessor with logic allows programming in the field. Controller has:

- STOP-MANUAL-AUTO modes and automatic engine shutdowns, signaled by full text LCD indicators:
- Low oil pressure
- High engine temp
- Low Radiator Level
- Three auxiliary alarms
- Battery fail alarm
- Engine fail to start
- Engine over speed
- Engine under speed
- Over & under voltage

Also included is tamper-proof engine hour meter

ENGINE:

Fuel filter • Full flow Oil filter • Air filter • Fuel pump • Oil pump • Solenoid type starter motor • Hi-temp radiator • Jacket water pump • Thermostat • Pusher fan and guard • Exhaust manifold • Electronic Governor • 24 VDC battery charging alternator • Flexible fuel and exhaust connectors • Vibration isolators • Open coolant recovery system with 50/50 water to anti-freeze mixture • flexible oil & radiator hose • Shut-down sensors for low oil pressure, high coolant temp., low coolant level, high ambient temp.

AC GENERATOR SYSTEM:

AC generator • Shunt excited • Brushless design • Circuit Breaker installed and wired to gen-set • Direct connection to engine with flex disc • Class H, 180°C insulation • Self ventilated • Drip proof construction • UL Certified

VOLTAGE REGULATOR:

1% Voltage regulation • EMI filter • Under-speed protection • Over-excitation protection • total encapsulation

DC ELECTRICAL SYSTEM:

Battery trays • Battery cables • Battery hold down straps • 3-stage battery charger with float, absorption, & bulk automatic charge stages

WEATHER / SOUNDPROOF ALUMINUM HOUSING:

Corrosion Resistant Protection consisting of:

- (9) Heated and Agitated Wash Stages
- Zinc Phosphate Etching-Coating Stage
- Final Baked on Enamel Powder Coat
- 18/8 Stainless Steel Hardware

Design & specifications subject to change without prior notice. Dimensions shown are approximate. Contact Gillette for certified drawings.

DO NOT USE DIMENSIONS FOR INSTALLATION PURPOSES.

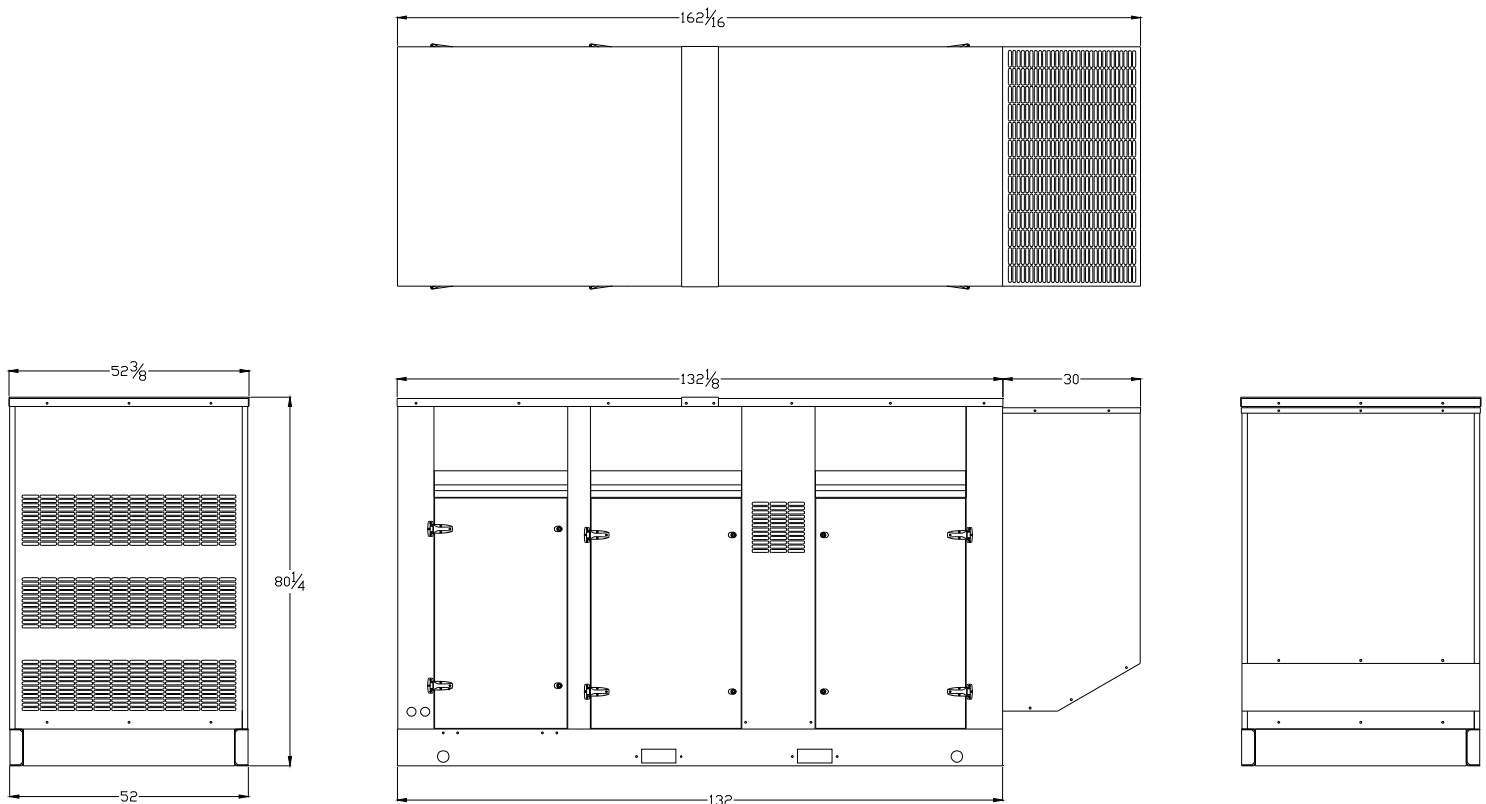

VOLVO PENTA GENSET ENGINE

TAD1352GE

356 kW (484 hp) at 1500 rpm, 395kW (537 hp) at 1800 rpm

A powerful, reliable and economical Generating Set Diesel Engine built on the dependable Volvo in-line six concept.

Energy efficiency and Economy

Through careful management of the combustion process, involving precise control of air movement and injection spray Volvo Penta has been able to achieve higher levels of efficiency than ever before. This has resulted in improved fuel economy and reduced exhaust emission levels that comply with current requirements and which will enable the engines to satisfy future legislation.

Volvo Penta engines offer the highest kWh/Liter fuel, resulting in superior economy and performance.

Durability & low noise

Designed for easy, fast and economical installation. Field tested to ensure highest standard of durability and long life. Well-balanced to produce smooth and vibration-free operation with low noise level.

To maintain a controlled working temperature in cylinders and combustion chambers, the engine is equipped with piston cooling. The engine is also fitted with replaceable cylinder liners and valve seats/guides to ensure maximum durability and service life of the engine.

Low exhaust emission

The state of the art, high-tech injection and highly efficient charge air system with low internal losses contributes to excellent combustion and low fuel consumption. The engine is EPA/CARB Tier 3 & EU Stage 3A emission certified. These regulations are met by using V-ACT™ (Volvo Advanced Combustion technology). V-ACT includes a flexible high pressure fuel injection system, an air management system including an internal exhaust gas recirculation device and an enhanced electronic controller.

Easy service & maintenance

Easily accessible service and maintenance points contribute to the ease of service of the engine.



Features

- Volvo Penta Electronic management system
- Certified for US/EPA Tier 3 and EU Stage 3A
- High efficient cooling system
- Compact design
- Base engines as well as Gen Pac configurations
- Switchable between 1500/1800 rpm
- Excellent step load performance acc. to ISO 8528-5 G3 governing class
- Low operating cost

50 Hz/1500 rpm

Prime power			Standby			Generator efficiency (%)
kWm	kWe	kVa	kWm	kWe	kVa	
313	291	364	344	320	400	93%

60 Hz/1800 rpm

Prime power			Standby			Generator efficiency (%)
kWm	kWe	kVa	kWm	kWe	kVa	
342	318	397	376	350	437	93%

TAD1352GE

Technical Data

General

Engine designation	TAD1352GE	
No. of cylinders and configuration	in-line 6	
Method of operation	4-stroke	
Bore, mm (in.)	131 (5.16)	
Stroke, mm (in.)	158 (6.22)	
Displacement, l (in ³)	12.78 (780)	
Compression ratio	18.1:1	
Dry weight, engine only, kg (lb)	1295 (2855)	
Dry weight with Gen Pac, kg (lb)	1715 (3781)	

Performance

	1500 rpm	1800 rpm
with fan, kW (hp) at:		
Prime Power	313 (426)	342 (465)
Max Standby Power	344 (468)	376 (511)
Fan power consumption, kW (hp)	12 (16)	19 (26)

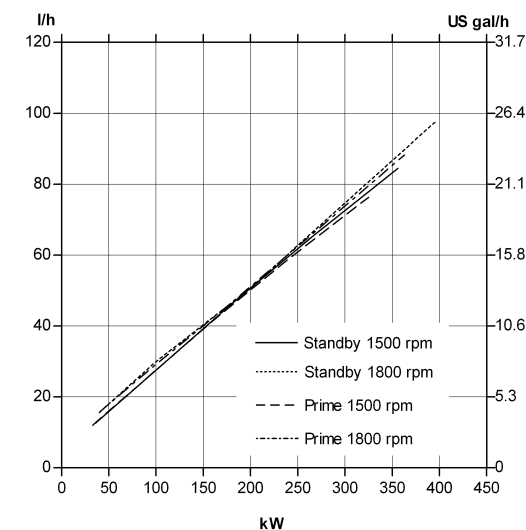

Dimensions TAD1352GE

Not for installation

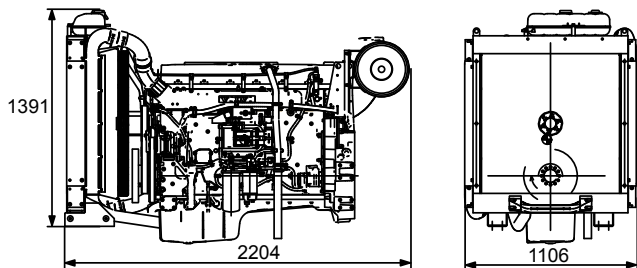

Note! Not all models, standard equipment and accessories are available in all countries. All specifications are subject to change without notice. The engine illustrated may not be entirely identical to production standard engines.

Power Standards

The engine performance corresponds to ISO 3046, BS 5514 and DIN 6271. The technical data applies to an engine without cooling fan and operating on a fuel with calorific value of 42.7 MJ/kg (18360 BTU/lb) and a density of 0.84 kg/liter (7.01 lb/US gal), also where this involves a deviation from the standards. Power output guaranteed within 0 to +2% at rated ambient conditions at delivery. Ratings are based on ISO 8528. Engine speed governing in accordance with ISO 3046/IV, class A1 and ISO 8528-5 class G3

Exhaust emissions

The engine complies with US/EPA Tier 3 and EU stage 3 A emission legislation according to the Non Road Directive EU 97/68/EEC. The engine also complies with TA-luft -50% exhaust emission regulations.

Rating Guidelines

PRIME POWER rating corresponds to ISO Standard Power for continuous operation. It is applicable for supplying electrical power at variable load for an unlimited number of hours instead of commercially purchased power. A10 % overload capability for governing purpose is available for this rating. STANDBY POWER rating corresponds to ISO Standard Fuel Stop Power. It is applicable for supplying standby electrical power at variable load in areas with well established electrical networks in the event of normal utility power failure. No overload capability is available for this rating.

1 hp = 1 kW x 1.36

Information

For more technical data and information, please look in the Generating Set Engines Sales Guide.

Technical description

Engine and block

- Cast iron cylinder block with optimum distribution of forces without the block being unnecessarily heavy.
- Wet, replaceable cylinder liners
- Piston cooling for low piston temperature and reduced ring temperature
- Tapered connecting rods for increased piston lifetime
- Crankshaft induction hardened bearing surfaces and fillets with seven bearings for moderate load on main and high-end bearings
- Case hardened and Nitrocarburized transmission gears for heavy duty operation
- Keystone top compression rings for long service life
- Viscous type crankshaft vibration dampers to withstand single bearing alternator torsional vibrations
- Replaceable valve guides and valve seats
- Over head camshaft and 4 valves per cylinder

Lubrication system

- Full flow oil cooler
- Full flow disposable spin-on oil filter, for extra high filtration
- The lubricating oil level can be measured at start-up
- Gear type lubricating oil pump, gear driven by the transmission

Fuel system

- Electronic high pressure unit injectors
- Fuel prefilter with water separator and water-in-fuel indicator / alarm
- Gear driven low-pressure fuel pump
- Fine fuel filter with manual feed pump and fuel pressure switch

Cooling system

- Efficient cooling with accurate coolant control through a water distribution duct in the cylinder block. Reliable sleeve thermostat with minimum pressure drop
- Belt driven coolant pump with high degree of efficiency

Turbo charger

- Efficient and reliable turbo charger
- Electronically controlled Waste-gate
- Extra oil filter for the turbo charger

Electrical system

- Engine Management System 2 (EMS 2), an electronically controlled processing system which optimizes engine performance. It also includes advanced facilities for diagnostics and fault tracing
- The instruments and controls connect to the engine via the CAN SAE J1939 interface, either through the Control Interface Unit (CIU) or the Digital Control Unit (DCU). The CIU converts the digital CAN bus signal to an analog signal, making it possible to connect a variety of instruments. The DCU is a control panel with display, engine control, monitoring, alarm, parameter setting and diagnostic functions. The DCU also presents error codes in clear text.
- Sensors for oil pressure, oil temp, boost pressure, boost temp, coolant temp, fuel temp, water in fuel, fuel pressure and two speed sensors.

VOLVO PENTA

AB Volvo Penta
SE-405 08 Göteborg, Sweden
www.volvopenta.com

S4L1D-F41 Wdg.311 - Technical Data Sheet

Standards

Stamford industrial alternators meet the requirements of the relevant parts of the BS EN 60034 and the relevant section of other international standards such as BS5000, VDE 0530, NEMA MG1-32, IEC34, CSA C22.2-100 and AS1359. Other standards and certifications can be considered on request.

Quality Assurance

Alternators are manufactured using production procedures having a quality assurance level to BS EN ISO 9001.

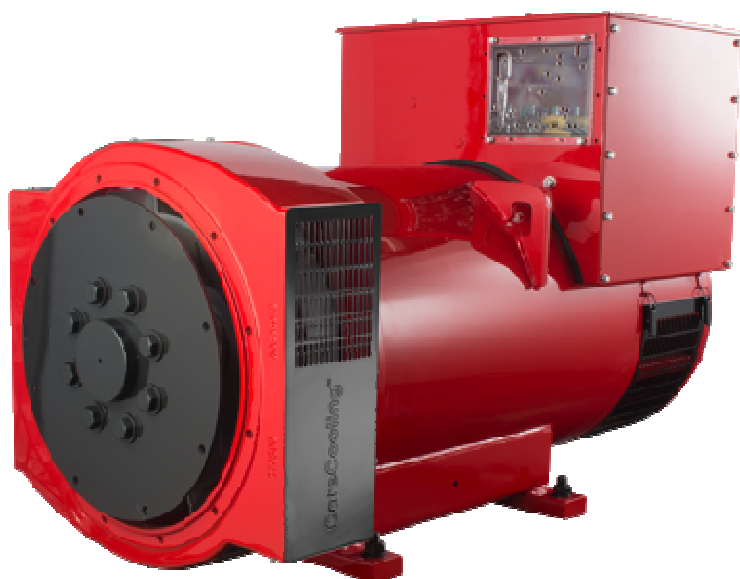

Excitation and Voltage Regulators

Excitation System					
AVR Type	AS440	MX341	MX321		
Voltage Regulation	± 1%	± 1%	± 0.5%		with 4% Engine Governing
Excitation Type	Self-Excited	PMG	PMG		

No Load Excitation Voltage (V)	10 - 8
No Load Excitation Current (A)	0.7 - 0.5
Full Load Excitation Voltage (V)	41 - 37.5
Full Load Excitation Current (A)	2.3 - 2.1
Exciter Time Constant (seconds)	0.105

STAMFORD

S4L1D-F41 Wdg.311

Electrical Data								
Insulation System	Class H							
Stator Winding	Double Layer Lap							
Winding Pitch	Two Thirds							
Winding Leads	12							
Winding Number	311							
Number of Poles	4							
IP Rating	IP23							
RFI Suppression	BS EN 61000-6-2 & BS EN 61000-6-4, VDE 0875G, VDE 0875N. Refer to factory for others							
Waveform Distortion	NO LOAD < 1.5% NON-DISTORTING BALANCED LINEAR LOAD < 5.0%							
Short Circuit Ratio	1/Xd							
Steady State X/R Ratio	13.7389							
	50 Hz				60 Hz			
Telephone Interference	THF<2%				TIF<50			
Cooling Air	0.76 m ³ /sec				0.92 m ³ /sec			
Voltage Star	380	400	415	440	416	440	460	480
kVA Base Rating (Class H) for Reactance Values	400	415	415	400	455	500	500	520
Saturated Values in Per Unit at Base Ratings and Voltages								
Xd Dir. Axis Synchronous	2.71	2.54	2.36	2.02	3.28	3.23	2.95	2.82
X'd Dir. Axis Transient	0.18	0.17	0.16	0.13	0.18	0.18	0.16	0.16
X''d Dir. Axis Subtransient	0.13	0.13	0.12	0.10	0.13	0.13	0.12	0.11
Xq Quad. Axis Reactance	2.34	2.19	2.03	1.74	2.90	2.84	2.60	2.49
X''q Quad. Axis Subtransient	0.31	0.29	0.27	0.23	0.42	0.42	0.38	0.36
XL Stator Leakage Reactance	0.06	0.05	0.05	0.04	0.07	0.07	0.07	0.06
X2 Negative Sequence Reactance	0.22	0.21	0.20	0.17	0.29	0.29	0.26	0.25
X0 Zero Sequence Reactance	0.09	0.08	0.08	0.07	0.10	0.10	0.09	0.08
Unsaturated Values in Per Unit at Base Ratings and Voltages								
Xd Dir. Axis Synchronous	3.26	3.05	2.83	2.43	3.94	3.87	3.54	3.38
X'd Dir. Axis Transient	0.21	0.19	0.18	0.15	0.21	0.21	0.19	0.18
X''d Dir. Axis Subtransient	0.16	0.15	0.14	0.12	0.16	0.15	0.14	0.13
Xq Quad. Axis Reactance	2.41	2.26	2.10	1.80	2.98	2.93	2.68	2.56
X''q Quad. Axis Subtransient	0.37	0.35	0.32	0.28	0.51	0.50	0.46	0.44
XL Stator Leakage Reactance	0.06	0.06	0.05	0.05	0.08	0.08	0.07	0.07
Xlr Rotor Leakage Reactance	0.10	0.09	0.09	0.07	0.11	0.11	0.10	0.10
X2 Negative Sequence Reactance	0.27	0.25	0.23	0.20	0.35	0.34	0.31	0.30
X0 Zero Sequence Reactance	0.10	0.10	0.09	0.08	0.11	0.11	0.10	0.10

STAMFORD®

S4L1D-F41 Wdg.311

Time Constants (Seconds)		
T'd TRANSIENT TIME CONST.	0.08	
T''d SUB-TRANSTIME CONST.	0.019	
T'do O.C. FIELD TIME CONST.	1.7	
Ta ARMATURE TIME CONST.	0.018	
T''q SUB-TRANSTIME CONST.	0.009	
Resistances in Ohms (Ω) at 22°C		
Stator Winding Resistance (Ra), per phase for series connected	0.0073	
Rotor Winding Resistance (Rf)	1.37	
Exciter Stator Winding Resistance	18	
Exciter Rotor Winding Resistance per phase	0.068	
PMG Phase Resistance (Rpmg) per phase	1.9	
Positive Sequence Resistance (R1)	0.009125	
Negative Sequence Resistance (R2)	0.010512	
Zero Sequence Resistance (R0)	0.009125	
Saturation Factors	400V	480V
SG1.0	0.36	0.38
SG1.2	1.46	1.52
Mechanical Data		
Shaft and Keys	All alternator rotors are dynamically balanced to better than BS6861: Part 1 Grade 2.5 for minimum vibration in operation. Two bearing generators are balanced with a half key.	
	1 Bearing	2 Bearings
SAE Adaptor	SAE 0.5, 1	N/A
Moment of Inertia	5.4292kgm ²	N/A
Weight Wound Stator	535kg	N/A
Weight Wound Rotor	463kg	N/A
Weight Complete Alternator	1160kg	N/A
Shipping weight in a Crate	1230kg	N/A
Packing Crate Size	155 x 87 x 107 (cm)	N/A
Maximum Over Speed	2250 RPM for two minutes	
Bearing Drive End	N/A	N/A
Bearing Non-Drive End	Ball 6314	N/A

STAMFORD®

S4L1D-F41 Wdg.311

THREE PHASE EFFICIENCY CURVES

50Hz

60Hz

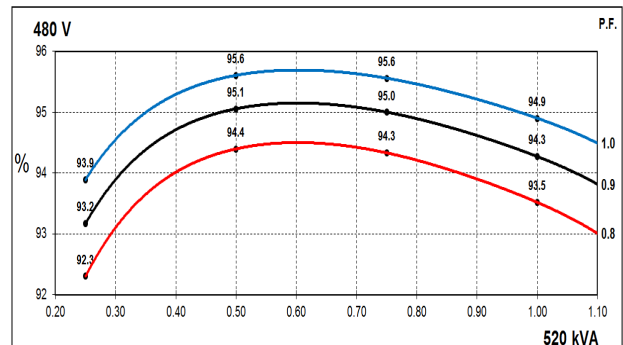
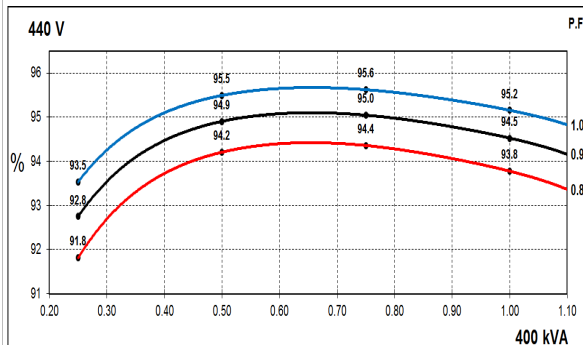
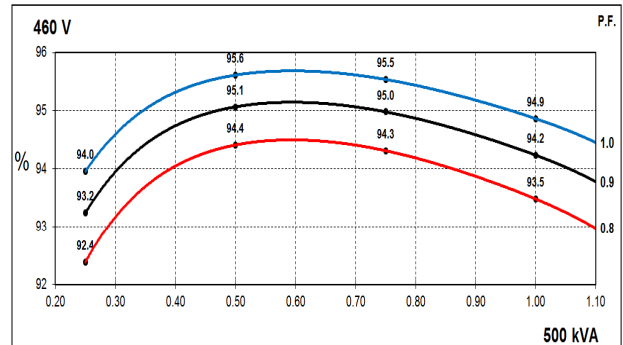
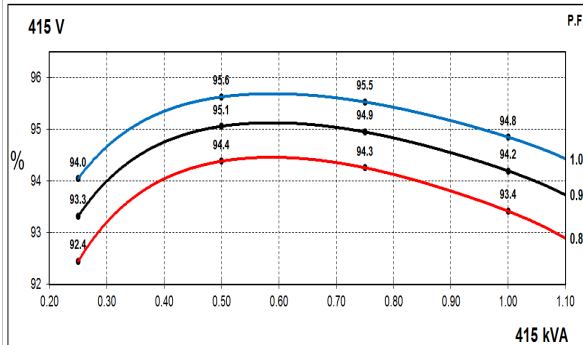
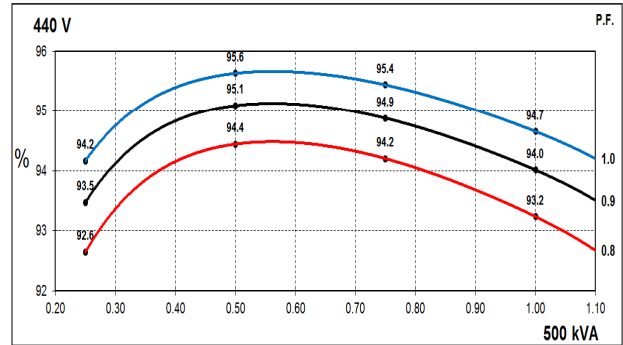
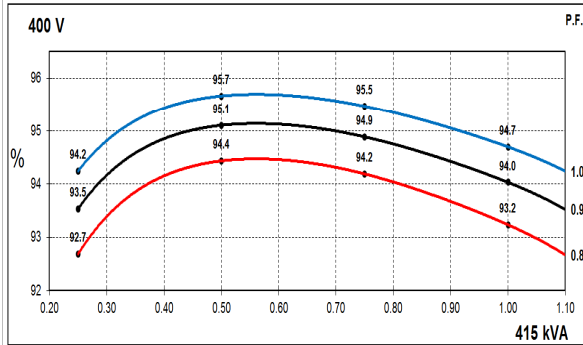
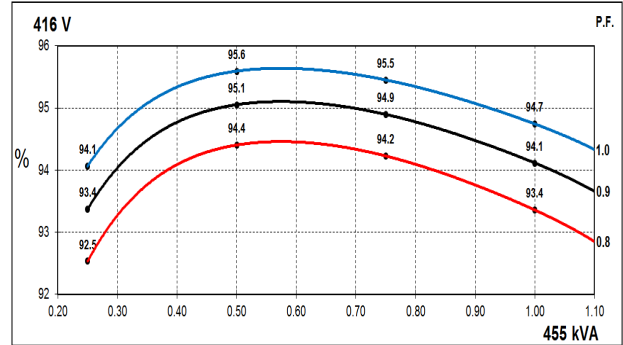
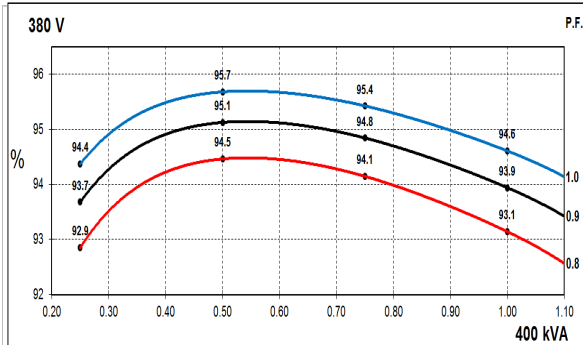

STAMFORD

S4L1D-F41 Wdg.311

Locked Rotor Motor Starting Curves - Separately Excited

50Hz

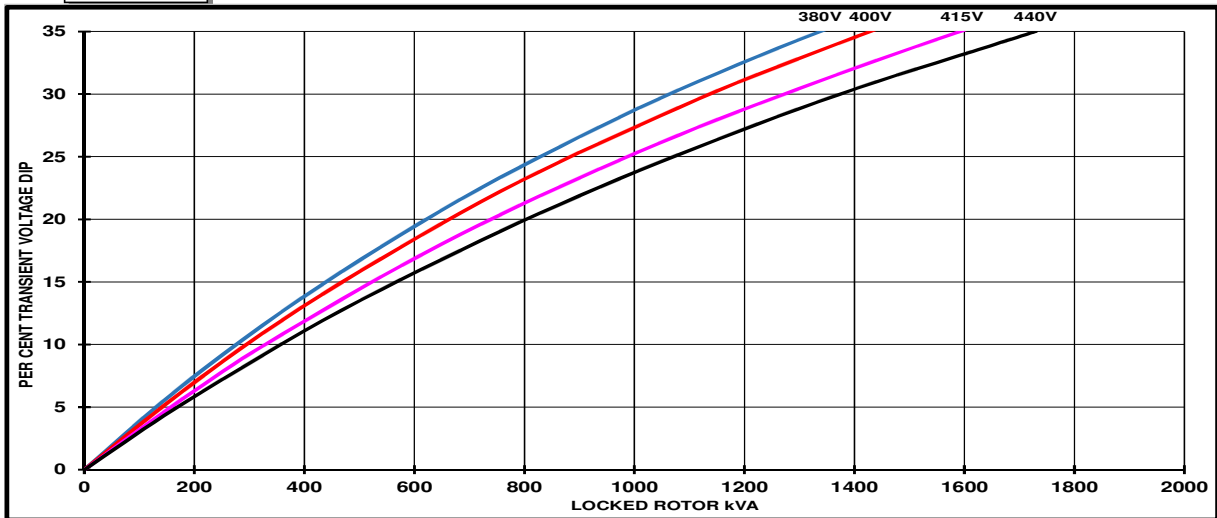

60Hz

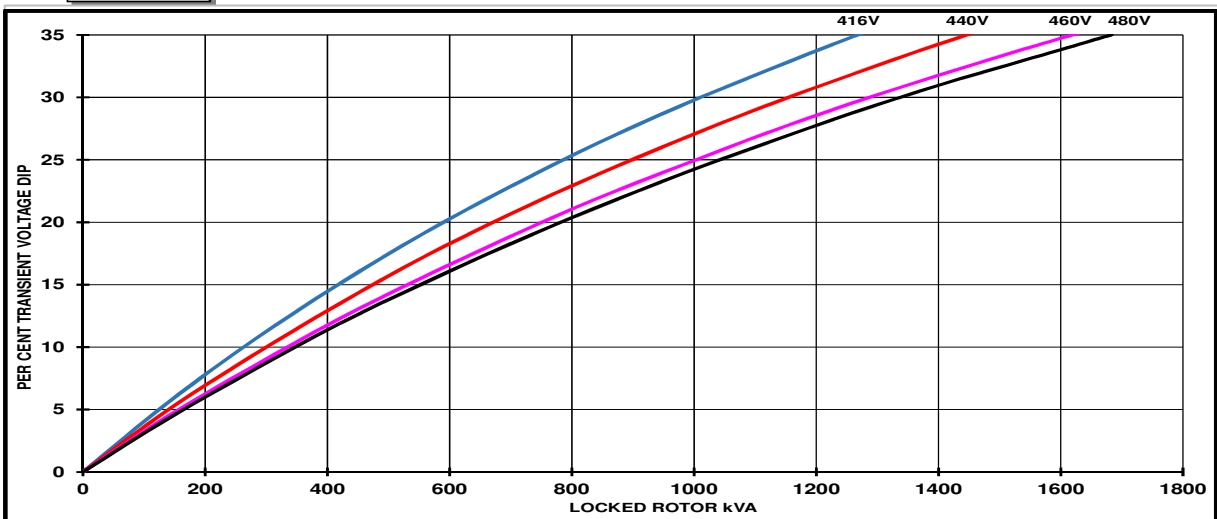

Transient Voltage Dip Scaling Factor		Transient Voltage Rise Scaling Factor
PF	Factor	
< 0.5	1	For voltage rise multiply voltage dip by 1.25
0.5	0.97	
0.6	0.93	
0.7	0.9	
0.8	0.85	
0.9	0.83	

STAMFORD

S4L1D-F41 Wdg.311

Locked Rotor Motor Starting Curves - Self Excited

50Hz

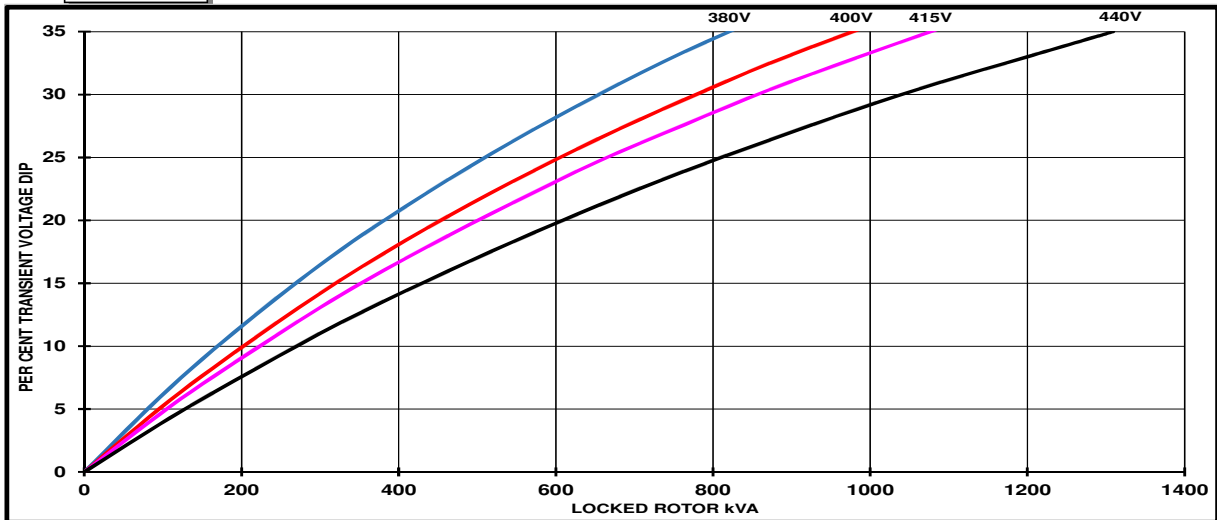

60Hz

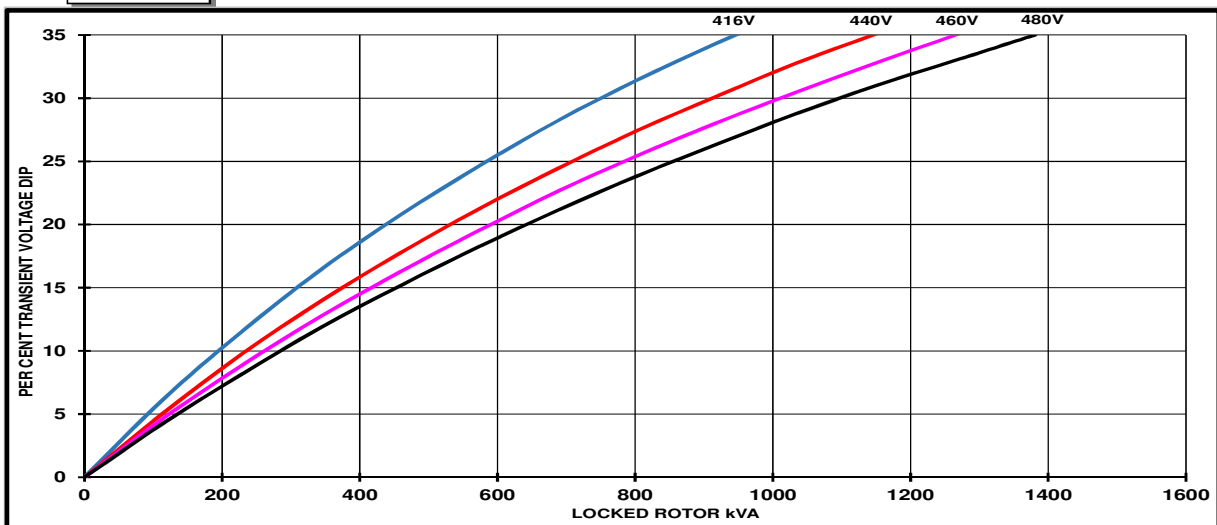

Transient Voltage Dip Scaling Factor		Transient Voltage Rise Scaling Factor
PF	Factor	
< 0.5	1	For voltage rise multiply voltage dip by 1.25
0.5	0.97	
0.6	0.93	
0.7	0.9	
0.8	0.85	
0.9	0.83	

STAMFORD®

S4L1D-F41 Wdg.311

Three-phase Short Circuit Decrement Curve

50Hz

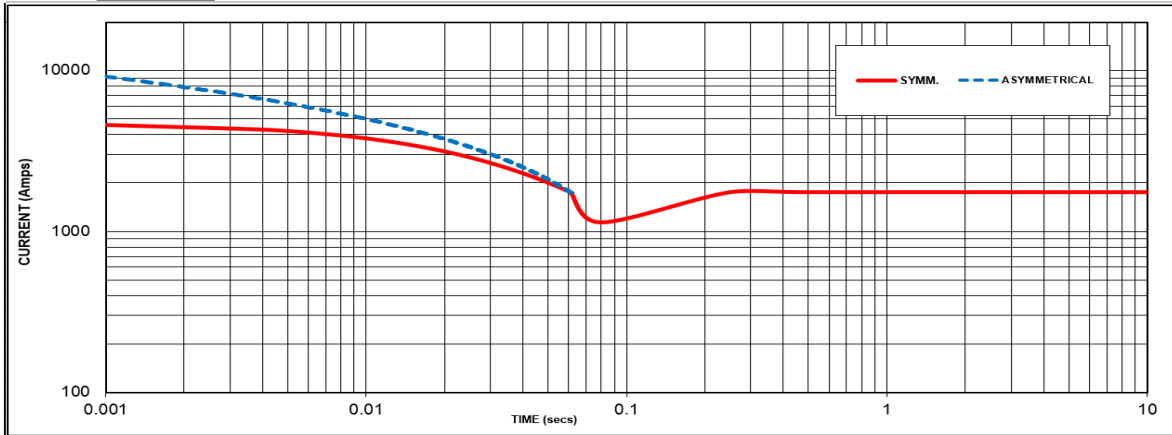

Sustained Short Circuit = 1750 Amps

60Hz

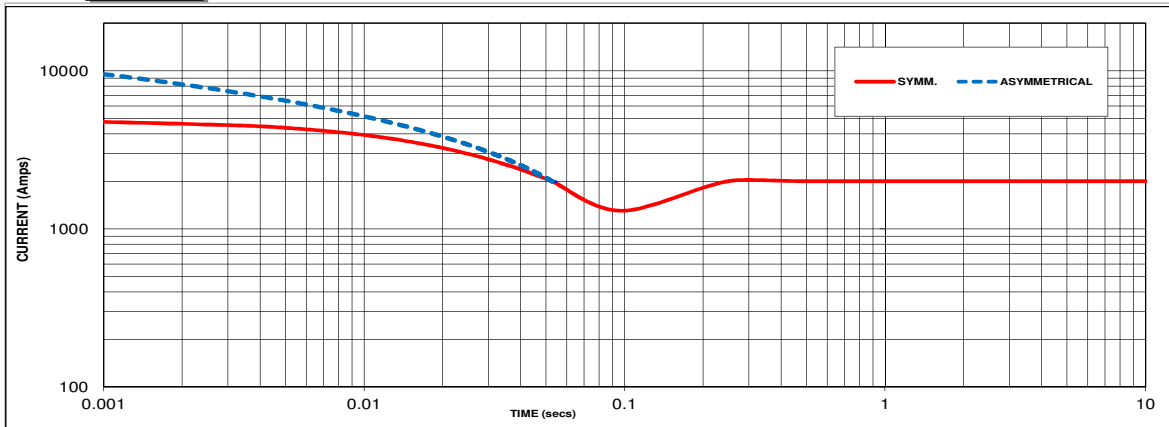

Sustained Short Circuit = 2000 Amps

Note 1

The following multiplication factors should be used to adjust the values from curve between time 0.001 seconds and the minimum current point in respect of nominal operating voltage :

50Hz		60Hz	
Voltage	Factor	Voltage	Factor
380V	X 1.00	416V	X 1.00
400V	X 1.05	440V	X 1.06
415V	X 1.09	460V	X 1.10
440V	X 1.16	480V	X 1.15

The sustained current value is constant irrespective of voltage level

Note 2

The following multiplication factor should be used to convert the values calculated in accordance with NOTE 1 to those applicable to the various types of short circuit :

	3-phase	2-phase L-L	1-phase L-N
Instantaneous	x 1.00	x 0.87	x 1.30
Minimum	x 1.00	x 1.80	x 3.20
Sustained	x 1.00	x 1.50	x 2.50
Max. sustained duration	10 sec.	5 sec.	2 sec.

All other times are unchanged

Note 3

Curves are drawn for Star connected machines under no-load excitation at rated speeds. For other connection the following multipliers should be applied to current values as shown :
 Parallel Star = Curve current value X 2
 Series Delta = Curve current value X 1.732

STAMFORD

S4L1D-F41 Wdg.311

Typical Alternator Operating Charts

400V/50Hz

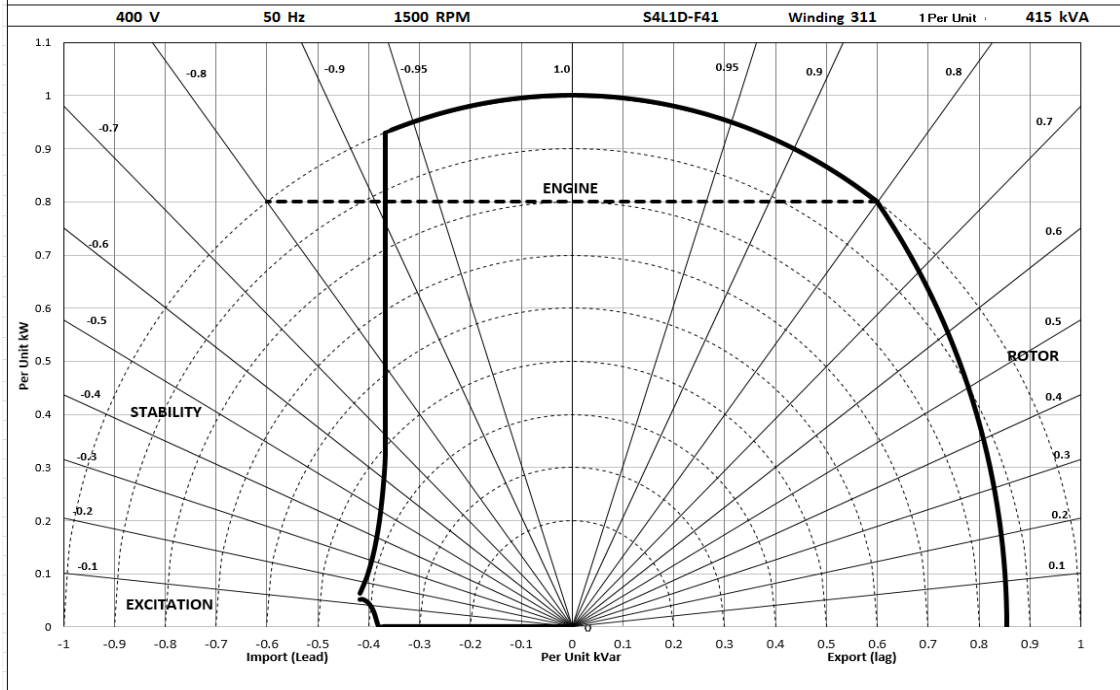

480V/60Hz

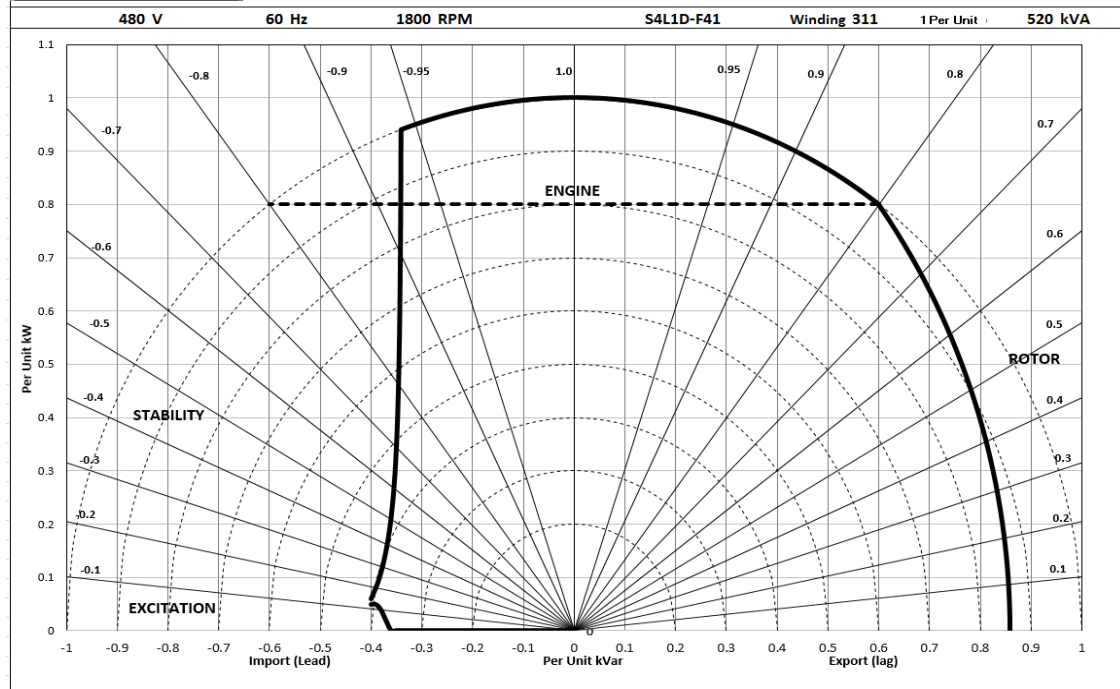

STAMFORD®

S4L1D-F41 Wdg.311

RATINGS AT 0.8 POWER FACTOR

Class - Temp Rise		Standby - 163/27°C				Standby - 150/40°C				Cont. H - 125/40°C				Cont. F - 105/40°C			
50 Hz	Series Star (V)	380	400	415	440	380	400	415	440	380	400	415	440	380	400	415	440
	kVA	425	465	455	440	415	445	445	430	400	415	415	400	370	380	380	370
	kW	340	372	364	352	332	356	356	344	320	332	332	320	296	304	304	296
	Efficiency (%)	92.8	92.6	92.9	93.4	92.9	92.9	93.1	93.5	93.1	93.2	93.4	93.8	93.5	93.6	93.8	94.0
	kW Input	366	402	392	377	357	383	383	368	344	356	355	341	317	325	324	315

60 Hz	Series Star (V)	416	440	460	480	416	440	460	480	416	440	460	480	416	440	460	480
	kVA	500	550	550	575	485	535	535	555	455	500	500	520	420	465	465	480
	kW	400	440	440	460	388	428	428	444	364	400	400	416	336	372	372	384
	Efficiency (%)	92.9	92.7	93.0	93.0	93.0	92.9	93.2	93.2	93.4	93.2	93.5	93.5	93.7	93.6	93.8	93.8
	kW Input	431	475	473	495	417	461	459	476	390	429	428	445	359	398	397	409

De-Rates

All values tabulated above are subject to the following reductions:

- 5% when air inlet filters are fitted
- 3% for every 500 meters by which the operating altitude exceeds 1000 meters above mean sea level
- 3% for every 5°C by which the operational ambient temperature exceeds 40°C
- For any other operating conditions impacting the cooling circuit please refer to applications

Note: Requirement for operating in an ambient exceeding 60°C and altitude exceeding 4000 meters must be referred to applications.

Dimensional and Torsional Drawing

For dimensional and torsional information please refer to the alternator General Arrangement and rotor drawings available on our website (<http://stamford-avk.com/>)

Note: Continuous development of our products means that the information contained in our data sheets can change without notice, and specifications should always be confirmed with Cummins Generator Technologies prior to purchase.



Follow us @stamfordavk



Cummins Generator Technologies



View our videos at youtube.com/stamfordavk

news.stamford-avk.com

For Applications Support:
applications@cummins.com

For Customer Service:
service-engineers@stamford-avk.com

For General Enquiries:
info@cumminsgeneratortechnologies.com

Copyright 2016. Cummins Generator Technologies Ltd. All rights reserved.
Cummins and the Cummins logo are registered trade marks of Cummins Inc.
STAMFORD is a registered trade mark of Cummins Generator Technologies Ltd.



S4LID-E41 Wdg.311 - Technical Data Sheet

Standards

Stamford industrial alternators meet the requirements of the relevant parts of the BS EN 60034 and the relevant section of other international standards such as BS5000, VDE 0530, NEMA MG1-32, IEC34, CSA C22.2-100 and AS1359. Other standards and certifications can be considered on request.

Quality Assurance

Alternators are manufactured using production procedures having a quality assurance level to BS EN ISO 9001.



Excitation and Voltage Regulators

Excitation System					
AVR Type	AS440	MX341	MX321		
Voltage Regulation	± 1%	± 1%	± 0.5%		with 4% Engine Governing
Excitation Type	Self-Excited	PMG	PMG		

No Load Excitation Voltage (V)	12 - 9
No Load Excitation Current (A)	0.7 - 0.5
Full Load Excitation Voltage (V)	41 - 39
Full Load Excitation Current (A)	2.3 - 2.2
Exciter Time Constant (seconds)	0.105

STAMFORD

S4LID-E41 Wdg.311

Electrical Data								
Insulation System	Class H							
Stator Winding	Double Layer Lap							
Winding Pitch	Two Thirds							
Winding Leads	12							
Winding Number	311							
Number of Poles	4							
IP Rating	IP23							
RFI Suppression	BS EN 61000-6-2 & BS EN 61000-6-4, VDE 0875G, VDE 0875N. Refer to factory for others							
Waveform Distortion	NO LOAD < 1.5% NON-DISTORTING BALANCED LINEAR LOAD < 5.0%							
Short Circuit Ratio	1/Xd							
Steady State X/R Ratio	13.56							
	50 Hz				60 Hz			
Telephone Interference	THF<2%				TIF<50			
Cooling Air	0.8 m³/sec				0.96 m³/sec			
Voltage Star	380	400	415	440	416	440	460	480
kVA Base Rating (Class H) for Reactance Values	350	360	360	350	400	435	440	455
Saturated Values in Per Unit at Base Ratings and Voltages								
Xd Dir. Axis Synchronous	3.01	2.79	2.59	2.24	3.47	3.38	3.12	2.97
X'd Dir. Axis Transient	0.20	0.19	0.17	0.15	0.21	0.20	0.19	0.18
X''d Dir. Axis Subtransient	0.14	0.13	0.12	0.11	0.15	0.14	0.13	0.12
Xq Quad. Axis Reactance	2.57	2.39	2.22	1.92	2.92	2.84	2.62	2.49
X''q Quad. Axis Subtransient	0.36	0.33	0.31	0.27	0.41	0.40	0.37	0.35
XL Stator Leakage Reactance	0.07	0.06	0.06	0.05	0.08	0.08	0.08	0.07
X2 Negative Sequence Reactance	0.24	0.23	0.21	0.18	0.28	0.27	0.25	0.24
X0 Zero Sequence Reactance	0.10	0.09	0.09	0.07	0.10	0.09	0.09	0.08
Unsaturated Values in Per Unit at Base Ratings and Voltages								
Xd Dir. Axis Synchronous	3.61	3.35	3.11	2.69	4.17	4.05	3.75	3.56
X'd Dir. Axis Transient	0.23	0.21	0.20	0.17	0.24	0.23	0.21	0.20
X''d Dir. Axis Subtransient	0.17	0.16	0.15	0.13	0.17	0.17	0.15	0.15
Xq Quad. Axis Reactance	2.65	2.46	2.29	1.98	3.00	2.92	2.70	2.57
X''q Quad. Axis Subtransient	0.43	0.40	0.37	0.32	0.49	0.48	0.44	0.42
XL Stator Leakage Reactance	0.08	0.07	0.07	0.06	0.10	0.09	0.09	0.08
Xlr Rotor Leakage Reactance	0.12	0.11	0.10	0.09	0.13	0.13	0.12	0.11
X2 Negative Sequence Reactance	0.29	0.27	0.25	0.22	0.33	0.32	0.30	0.29
X0 Zero Sequence Reactance	0.12	0.11	0.10	0.09	0.11	0.11	0.10	0.10

STAMFORD

S4LID-E41 Wdg.311

Time Constants (Seconds)		
T'd TRANSIENT TIME CONST.	0.08	
T''d SUB-TRANSTIME CONST.	0.019	
T'do O.C. FIELD TIME CONST.	1.7	
Ta ARMATURE TIME CONST.	0.018	
T''q SUB-TRANSTIME CONST.	0.0079	
Resistances in Ohms (Ω) at 22°C		
Stator Winding Resistance (Ra), per phase for series connected	0.009	
Rotor Winding Resistance (Rf)	1.19	
Exciter Stator Winding Resistance	18	
Exciter Rotor Winding Resistance per phase	0.068	
PMG Phase Resistance (Rpmg) per phase	1.9	
Positive Sequence Resistance (R1)	0.01125	
Negative Sequence Resistance (R2)	0.01296	
Zero Sequence Resistance (R0)	0.01125	
Saturation Factors	400V	480V
SG1.0	0.32	0.33
SG1.2	1.3	1.32
Mechanical Data		
Shaft and Keys	All alternator rotors are dynamically balanced to better than BS6861: Part 1 Grade 2.5 for minimum vibration in operation. Two bearing generators are balanced with a half key.	
	1 Bearing	2 Bearings
SAE Adaptor	SAE 0.5, 1	N/A
Moment of Inertia	4.6331kgm ²	N/A
Weight Wound Stator	470kg	N/A
Weight Wound Rotor	400kg	N/A
Weight Complete Alternator	1024kg	N/A
Shipping weight in a Crate	1095kg	N/A
Packing Crate Size	155 x 87 x 107 (cm)	N/A
Maximum Over Speed	2250 RPM for two minutes	
Bearing Drive End	N/A	N/A
Bearing Non-Drive End	Ball 6314	N/A

STAMFORD®

S4LID-E41 Wdg.311

THREE PHASE EFFICIENCY CURVES

50Hz

60Hz

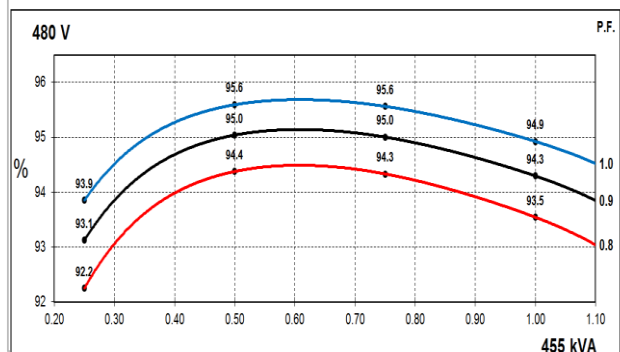
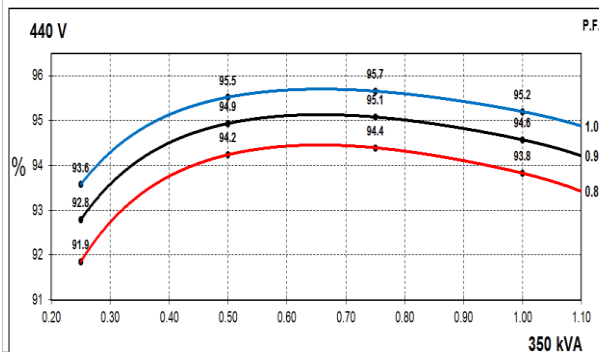
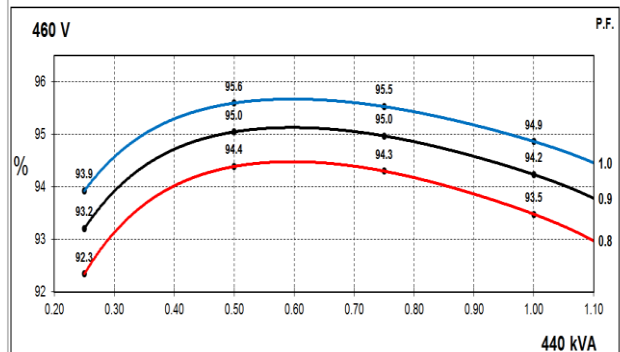
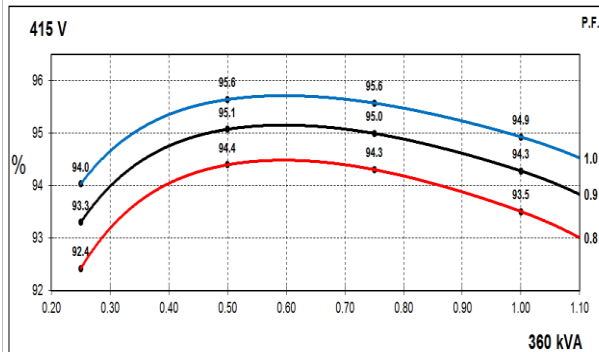
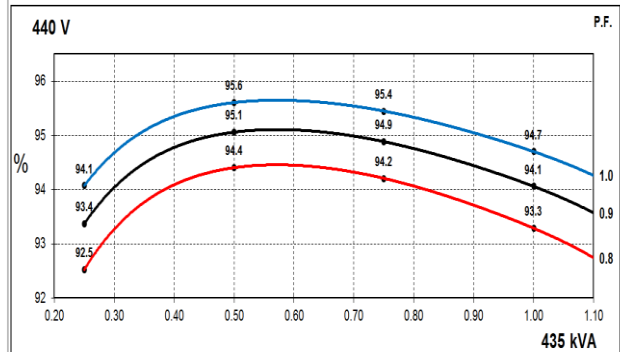
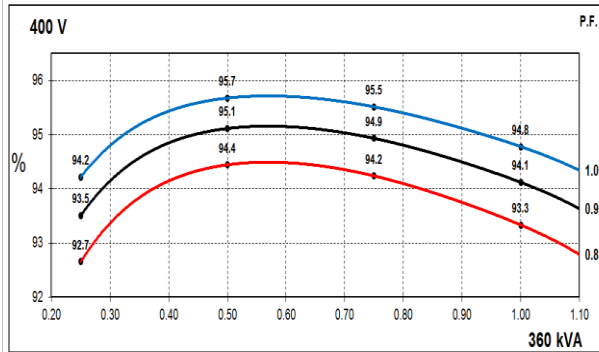
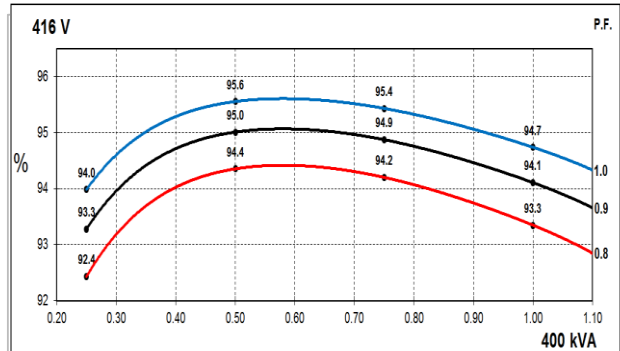
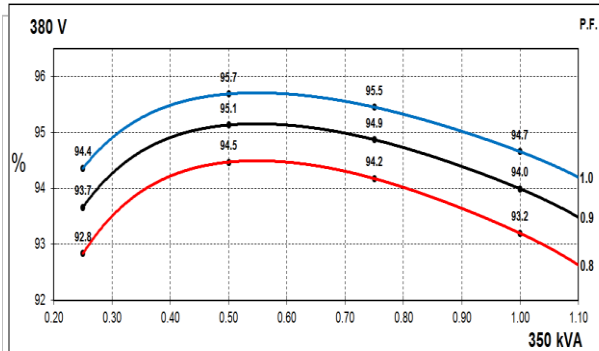

STAMFORD

S4LID-E41 Wdg.311

Locked Rotor Motor Starting Curves - Separately Excited

50Hz

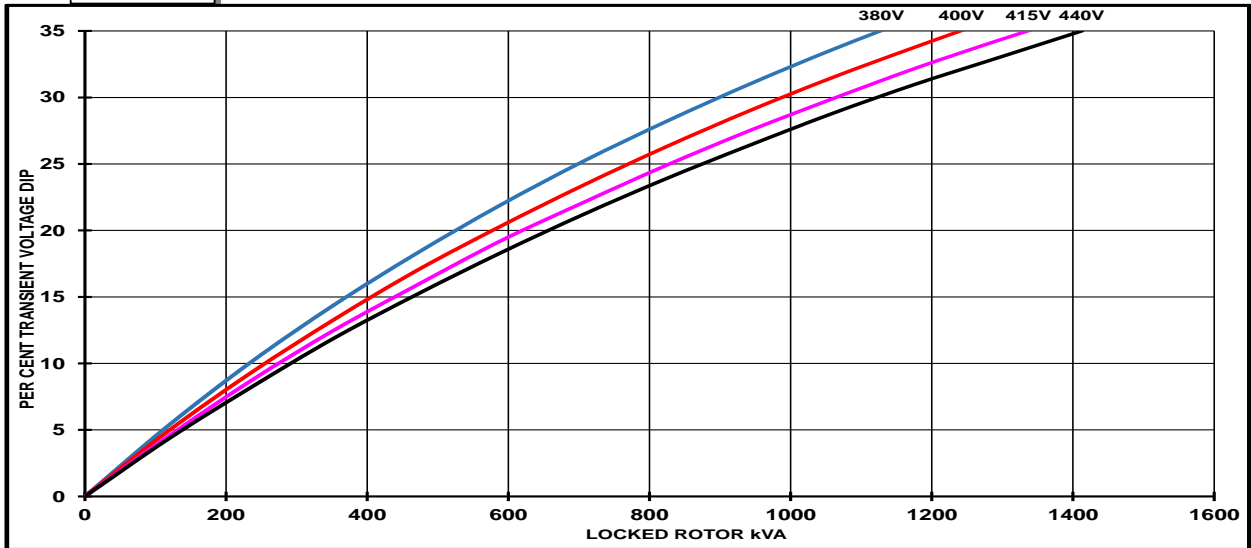

60Hz

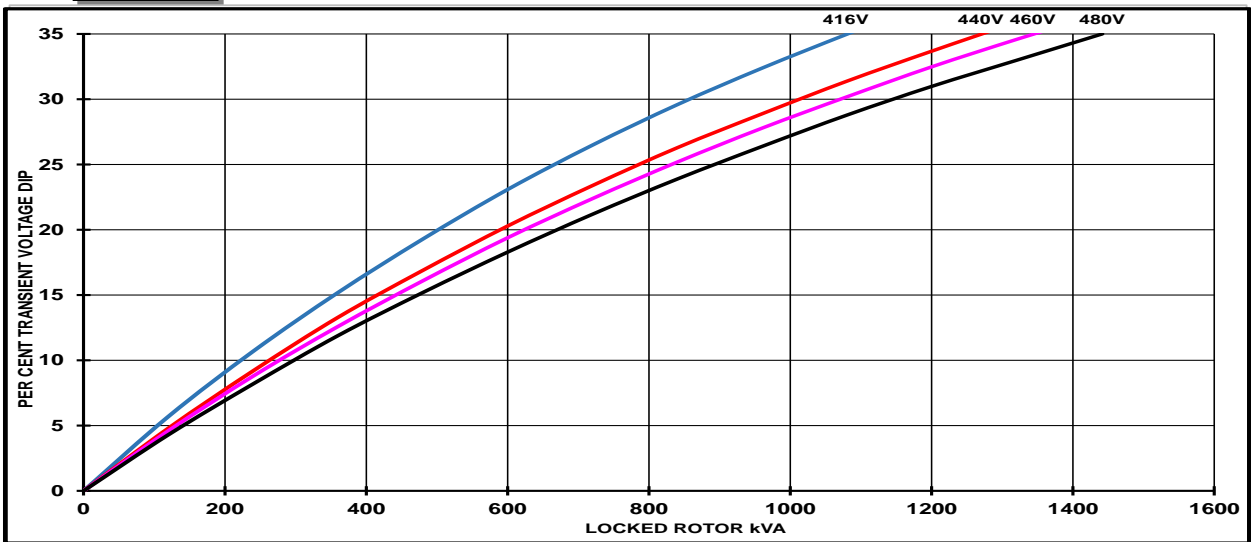

Transient Voltage Dip Scaling Factor		Transient Voltage Rise Scaling Factor
PF	Factor	
< 0.5	1	For voltage rise multiply voltage dip by 1.25
0.5	0.97	
0.6	0.93	
0.7	0.9	
0.8	0.85	
0.9	0.83	

STAMFORD

S4LID-E41 Wdg.311

Locked Rotor Motor Starting Curves - Self Excited

50Hz

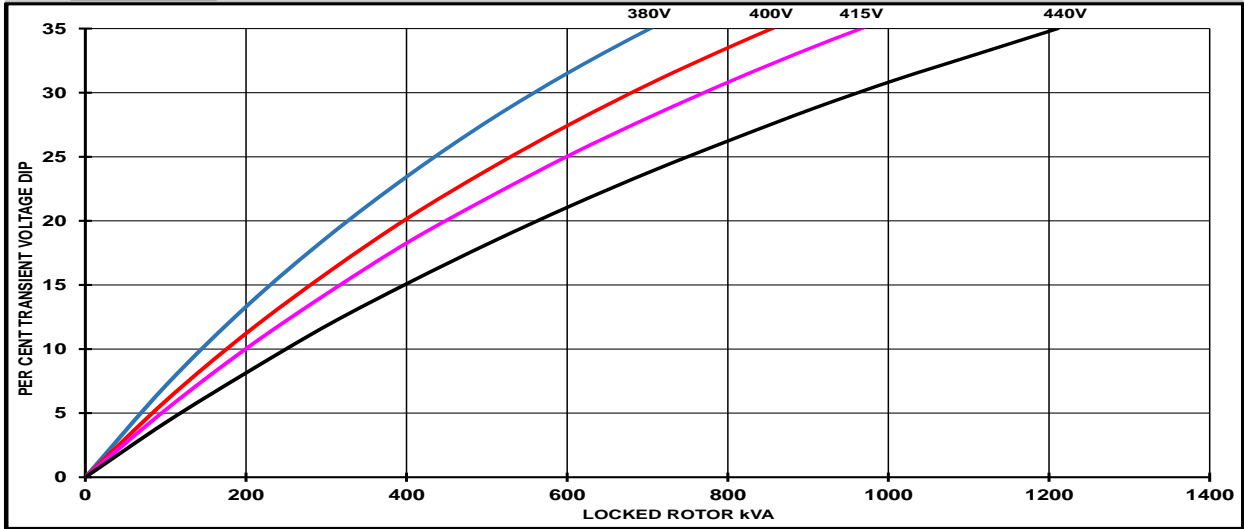

60Hz

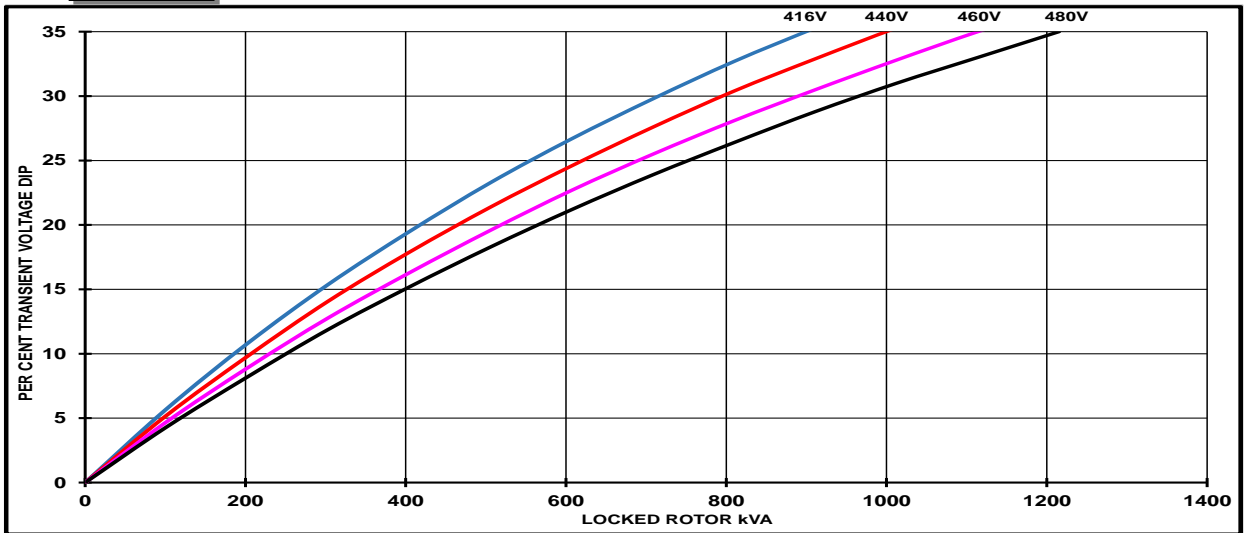

Transient Voltage Dip Scaling Factor		Transient Voltage Rise Scaling Factor
PF	Factor	
< 0.5	1	For voltage rise multiply voltage dip by 1.25
0.5	0.97	
0.6	0.93	
0.7	0.9	
0.8	0.85	
0.9	0.83	

STAMFORD[®]

S4LID-E41 Wdg.311

Three-phase Short Circuit Decrement Curve

50Hz

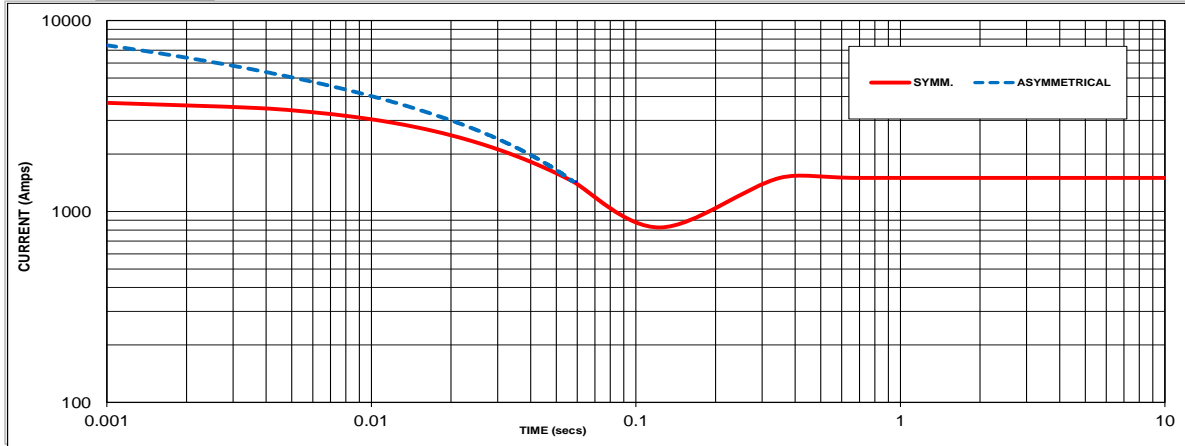

Sustained Short Circuit = 1500 Amps

60Hz

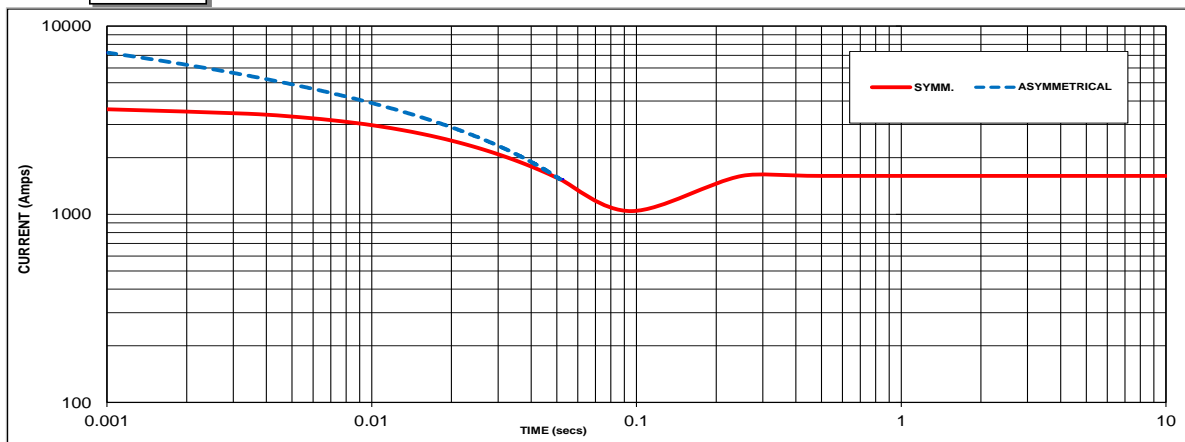

Sustained Short Circuit = 1600 Amps

Note 1

The following multiplication factors should be used to adjust the values from curve between time 0.001 seconds and the minimum current point in respect of nominal operating voltage :

50Hz		60Hz	
Voltage	Factor	Voltage	Factor
380V	X 1.00	416V	X 1.00
400V	X 1.05	440V	X 1.06
415V	X 1.09	460V	X 1.10
440V	X 1.16	480V	X 1.15

The sustained current value is constant irrespective of voltage level

Note 2

The following multiplication factor should be used to convert the values calculated in accordance with NOTE 1 to those applicable to the various types of short circuit :

	3-phase	2-phase L-L	1-phase L-N
Instantaneous	x 1.00	x 0.87	x 1.30
Minimum	x 1.00	x 1.80	x 3.20
Sustained	x 1.00	x 1.50	x 2.50
Max. sustained duration	10 sec.	5 sec.	2 sec.

All other times are unchanged

Note 3

Curves are drawn for Star connected machines under no-load excitation at rated speeds. For other connection the following multipliers should be applied to current values as shown :
 Parallel Star = Curve current value X 2
 Series Delta = Curve current value X 1.732

STAMFORD

S4LID-E41 Wdg.311

Typical Alternator Operating Charts

400V/50Hz

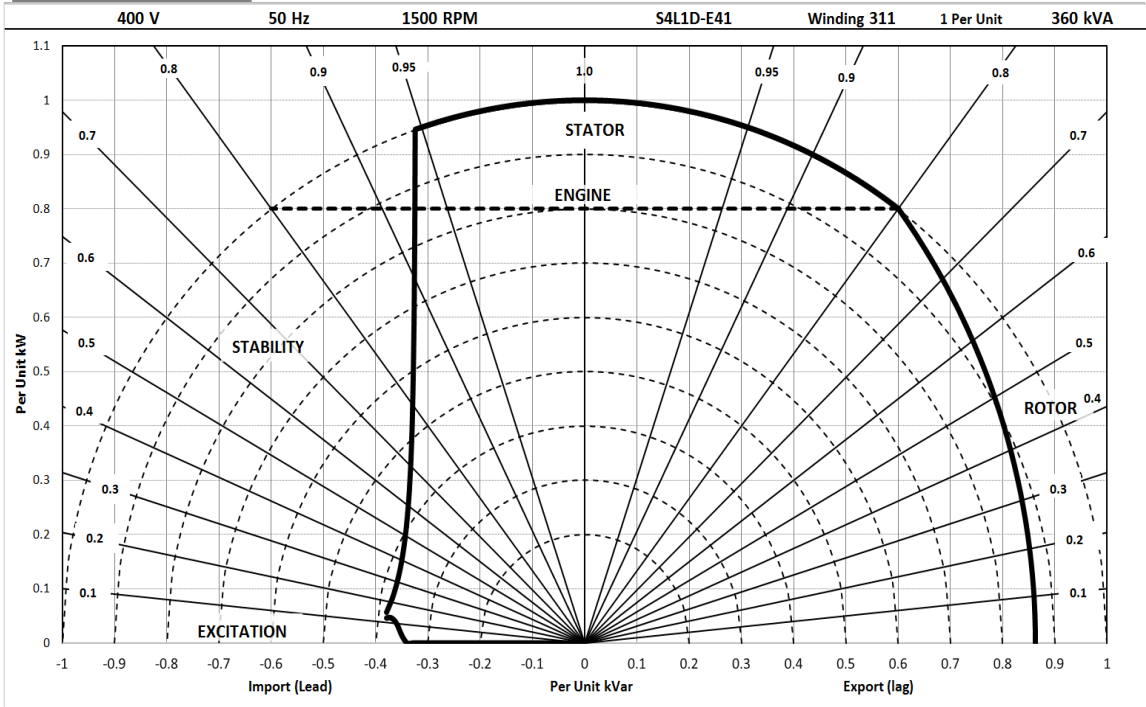

480V/60Hz

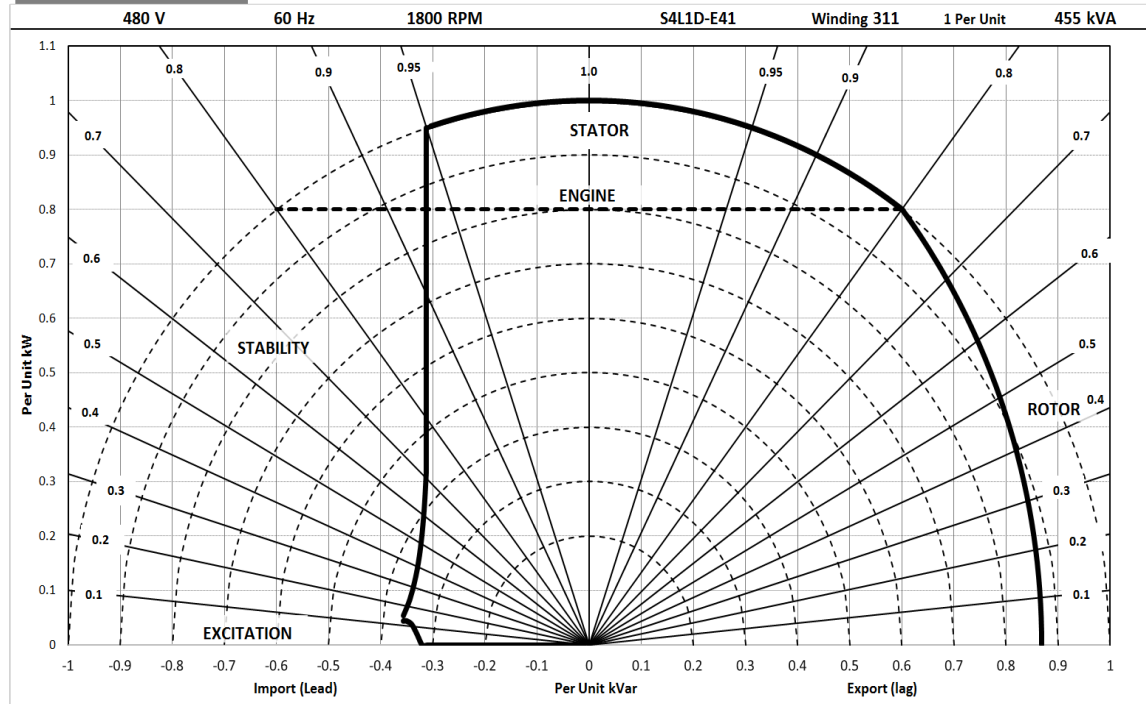

STAMFORD®

S4LID-E41 Wdg.311

RATINGS AT 0.8 POWER FACTOR

Class - Temp Rise		Standby - 163/27°C				Standby - 150/40°C				Cont. H - 125/40°C				Cont. F - 105/40°C			
50 Hz	Series Star (V)	380	400	415	440	380	400	415	440	380	400	415	440	380	400	415	440
	kVA	380	415	400	380	370	385	385	370	350	360	360	350	320	325	325	320
	kW	304	332	320	304	296	308	308	296	280	288	288	280	256	260	260	256
	Efficiency (%)	92.7	92.5	93.0	93.5	92.9	93.0	93.2	93.6	93.2	93.3	93.5	93.8	93.6	93.8	93.9	94.1
	kW Input	328	359	344	325	319	331	331	316	300	309	308	298	274	277	277	272

60 Hz	Series Star (V)	416	440	460	480	416	440	460	480	416	440	460	480	416	440	460	480
	kVA	435	470	475	490	420	460	460	475	400	435	440	455	365	395	400	410
	kW	348	376	380	392	336	368	368	380	320	348	352	364	292	316	320	328
	Efficiency (%)	92.9	92.9	93.1	93.2	93.1	93.0	93.3	93.3	93.4	93.3	93.5	93.5	93.7	93.7	93.9	93.9
	kW Input	374	405	408	421	361	396	395	407	343	373	377	389	312	337	341	349

De-Rates

All values tabulated above are subject to the following reductions:

- 5% when air inlet filters are fitted
- 3% for every 500 meters by which the operating altitude exceeds 1000 meters above mean sea level
- 3% for every 5°C by which the operational ambient temperature exceeds 40°C
- For any other operating conditions impacting the cooling circuit please refer to applications

Note: Requirement for operating in an ambient exceeding 60°C and altitude exceeding 4000 meters must be referred to applications.

Dimensional and Torsional Drawing

For dimensional and torsional information please refer to the alternator General Arrangement and rotor drawings available on our website (<http://stamford-avk.com/>)

Note: Continuous development of our products means that the information contained in our data sheets can change without notice, and specifications should always be confirmed with Cummins Generator Technologies prior to purchase.



Follow us @stamfordavk



Cummins Generator Technologies



View our videos at youtube.com/stamfordavk

news.stamford-avk.com

For Applications Support:
applications@cummins.com

For Customer Service:
service-engineers@stamford-avk.com

For General Enquiries:
info@cumminsgeneratortechnologies.com

Copyright 2016. Cummins Generator Technologies Ltd. All rights reserved.
Cummins and the Cummins logo are registered trade marks of Cummins Inc.
STAMFORD is a registered trade mark of Cummins Generator Technologies Ltd.



STAMFORD®

HCI434E/444E - Winding 17

Technical  Data Sheet

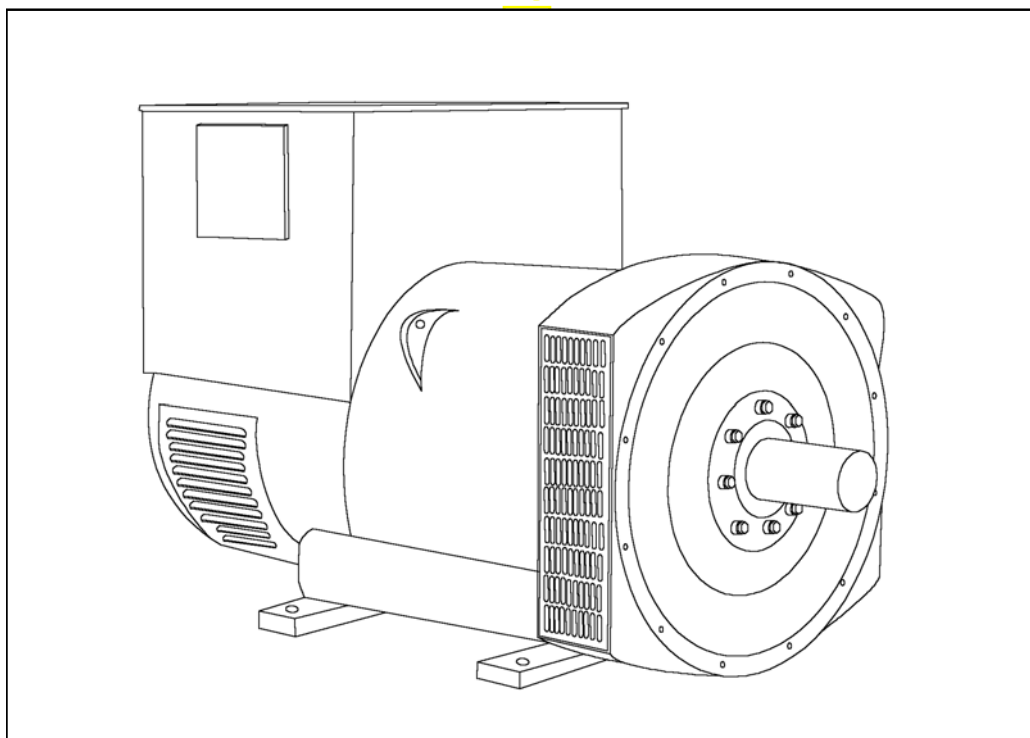

HCI434E/444E

SPECIFICATIONS & OPTIONS

STAMFORD

STANDARDS

Stamford industrial generators meet the requirements of BS EN 60034 and the relevant section of other international standards such as BS5000, VDE 0530, NEMA MG1-32, IEC34, CSA C22.2-100, AS1359. Other standards and certifications can be considered on request.

VOLTAGE REGULATORS

AS440 AVR - STANDARD

With this self-excited system the main stator provides power via the Automatic Voltage Regulator (AVR) to the exciter stator. The high efficiency semi-conductors of the AVR ensure positive build-up from initial low levels of residual voltage.

The exciter rotor output is fed to the main rotor through a three-phase full-wave bridge rectifier. The rectifier is protected by a surge suppressor against surges caused, for example, by short circuit or out-of-phase paralleling.

The AS440 will support a range of electronic accessories, including a 'droop' Current Transformer (CT) to permit parallel operation with other ac generators.

MX341 AVR

This sophisticated AVR is incorporated into the Stamford Permanent Magnet Generator (PMG) control system.

The PMG provides power via the AVR to the main exciter, giving a source of constant excitation power independent of generator output. The main exciter output is then fed to the main rotor, through a full wave bridge, protected by a surge suppressor. The AVR has in-built protection against sustained over-excitation, caused by internal or external faults. This de-excites the machine after a minimum of 5 seconds.

An engine relief load acceptance feature can enable full load to be applied to the generator in a single step.

If three-phase sensing is required with the PMG system the MX321 AVR must be used.

We recommend three-phase sensing for applications with greatly unbalanced or highly non-linear loads.

MX321 AVR

The most sophisticated of all our AVRs combines all the features of the MX341 with, additionally, three-phase rms sensing, for improved regulation and performance.

Over voltage protection is built-in and short circuit current level adjustments is an optional facility.

WINDINGS & ELECTRICAL PERFORMANCE

All generator stators are wound to 2/3 pitch. This eliminates triplen (3rd, 9th, 15th ...) harmonics on the voltage waveform and is found to be the optimum design for trouble-free supply of non-linear loads. The 2/3 pitch design avoids excessive neutral currents sometimes seen with higher winding pitches, when in parallel with the mains. A fully connected damper winding reduces oscillations during paralleling. This winding, with the 2/3 pitch and carefully selected pole and tooth designs, ensures very low waveform distortion.

TERMINALS & TERMINAL BOX

Standard generators are 3-phase reconnectable with 12 ends brought out to the terminals, which are mounted on a cover at the non-drive end of the generator. A sheet steel terminal box contains the AVR and provides ample space for the customers' wiring and gland arrangements. It has removable panels for easy access.

SHAFT & KEYS

All generator rotors are dynamically balanced to better than BS6861:Part 1 Grade 2.5 for minimum vibration in operation. Two bearing generators are balanced with a half key.

INSULATION/IMPREGNATION

The insulation system is class 'H'.

All wound components are impregnated with materials and processes designed specifically to provide the high build required for static windings and the high mechanical strength required for rotating components.

QUALITY ASSURANCE

Generators are manufactured using production procedures having a quality assurance level to BS EN ISO 9001.

The stated voltage regulation may not be maintained in the presence of certain radio transmitted signals. Any change in performance will fall within the limits of Criteria 'B' of EN 61000-6-2:2001. At no time will the steady-state voltage regulation exceed 2%.

DE RATES

All values tabulated on page 6 are subject to the following reductions

5% when air inlet filters are fitted.

3% for every 500 metres by which the operating altitude exceeds 1000 metres above mean sea level.

3% for every 5 C by which the operational ambient temperature exceeds 40 C.

Note: Requirement for operating in an ambient exceeding 60 C must be referred to the factory.

NB Continuous development of our products entitles us to change specification details without notice, therefore they must not be regarded as binding.

Front cover drawing typical of product range.

APPROVED DOCUMENT

HCI434E/444E

STAMFORD

WINDING 17

CONTROL SYSTEM	SEPARATELY EXCITED BY P.M.G.		
A.V.R.	MX321	MX341	
VOLTAGE REGULATION	± 0.5 %	± 1.0 %	With 4% ENGINE GOVERNING
SUSTAINED SHORT CIRCUIT	REFER TO SHORT CIRCUIT DECREMENT CURVES (page 5)		
CONTROL SYSTEM	SELF EXCITED		
A.V.R.	AS440		
VOLTAGE REGULATION	± 1.0 %		With 4% ENGINE GOVERNING
SUSTAINED SHORT CIRCUIT	WILL NOT SUSTAIN A SHORT CIRCUIT		
INSULATION SYSTEM	CLASS H		
PROTECTION	IP23		
RATED POWER FACTOR	0.8		
STATOR WINDING	DOUBLE LAYER LAP		
WINDING PITCH	TWO THIRDS		
WINDING LEADS	12		
STATOR WDG. RESISTANCE	0.015 Ohms PER PHASE AT 22°C SERIES STAR CONNECTED		
ROTOR WDG. RESISTANCE	1.19 Ohms at 22°C		
EXCITER STATOR RESISTANCE	18 Ohms at 22°C		
EXCITER ROTOR RESISTANCE	0.068 Ohms PER PHASE AT 22°C		
R.F.I. SUPPRESSION	BS EN 61000-6-2 & BS EN 61000-6-4, VDE 0875G, VDE 0875N. refer to factory for others		
WAVEFORM DISTORTION	NO LOAD < 1.5% NON-DISTORTING BALANCED LINEAR LOAD < 5.0%		
MAXIMUM OVERSPEED	2250 Rev/Min		
BEARING DRIVE END	BALL. 6317 (ISO)		
BEARING NON-DRIVE END	BALL. 6314 (ISO)		
	1 BEARING	2 BEARING	
WEIGHT COMP. GENERATOR	1024 kg	1030 kg	
WEIGHT WOUND STATOR	470 kg	470 kg	
WEIGHT WOUND ROTOR	400 kg	377 kg	
WR ² INERTIA	4.6331 kgm ²	4.4343 kgm ²	
SHIPPING WEIGHTS in a crate	1095 kg	1100 kg	
PACKING CRATE SIZE	155 x 87 x 107 (cm)	155 x 87 x 107 (cm)	
TELEPHONE INTERFERENCE	THF < 2%	TIF < 50	
COOLING AIR	0.99 m ³ /sec 2100 cfm		
VOLTAGE SERIES STAR	600V		
VOLTAGE PARALLEL STAR	300V		
VOLTAGE SERIES DELTA	346V		
KVA BASE RATING FOR REACTANCE VALUES	440		
X _d DIR. AXIS SYNCHRONOUS	2.67		
X' _d DIR. AXIS TRANSIENT	0.18		
X'' _d DIR. AXIS SUBTRANSIENT	0.13		
X _q QUAD. AXIS REACTANCE	2.24		
X'' _q QUAD. AXIS SUBTRANSIENT	0.31		
X _L LEAKAGE REACTANCE	0.06		
X ₂ NEGATIVE SEQUENCE	0.21		
X ₀ ZERO SEQUENCE	0.07		
REACTANCES ARE SATURATED		VALUES ARE PER UNIT AT RATING AND VOLTAGE INDICATED	
T' _d TRANSIENT TIME CONST.	0.08s		
T'' _d SUB-TRANSTIME CONST.	0.019s		
T' _{do} O.C. FIELD TIME CONST.	1.7s		
T _a ARMATURE TIME CONST.	0.018s		
SHORT CIRCUIT RATIO	1/X _d		

HCI434E/444E

STAMFORD

Winding 17

SX

Locked Rotor Motor Starting Curves

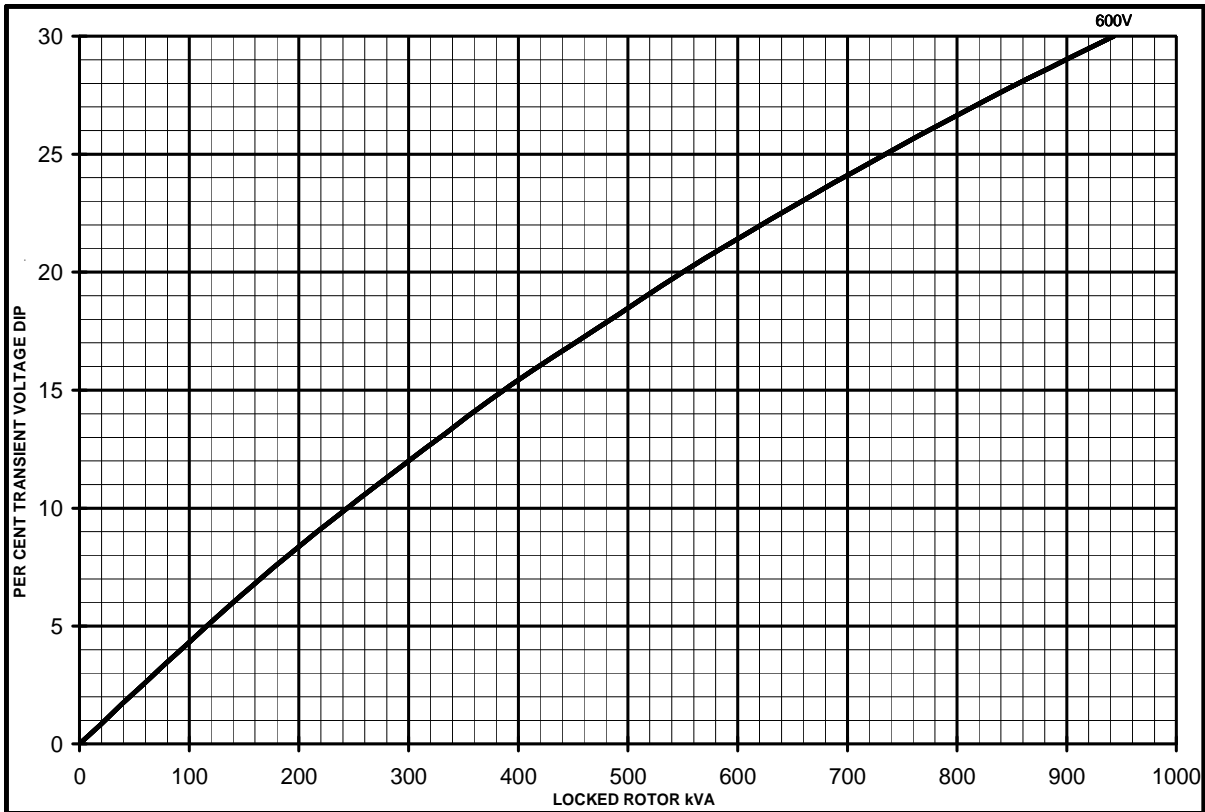

MX

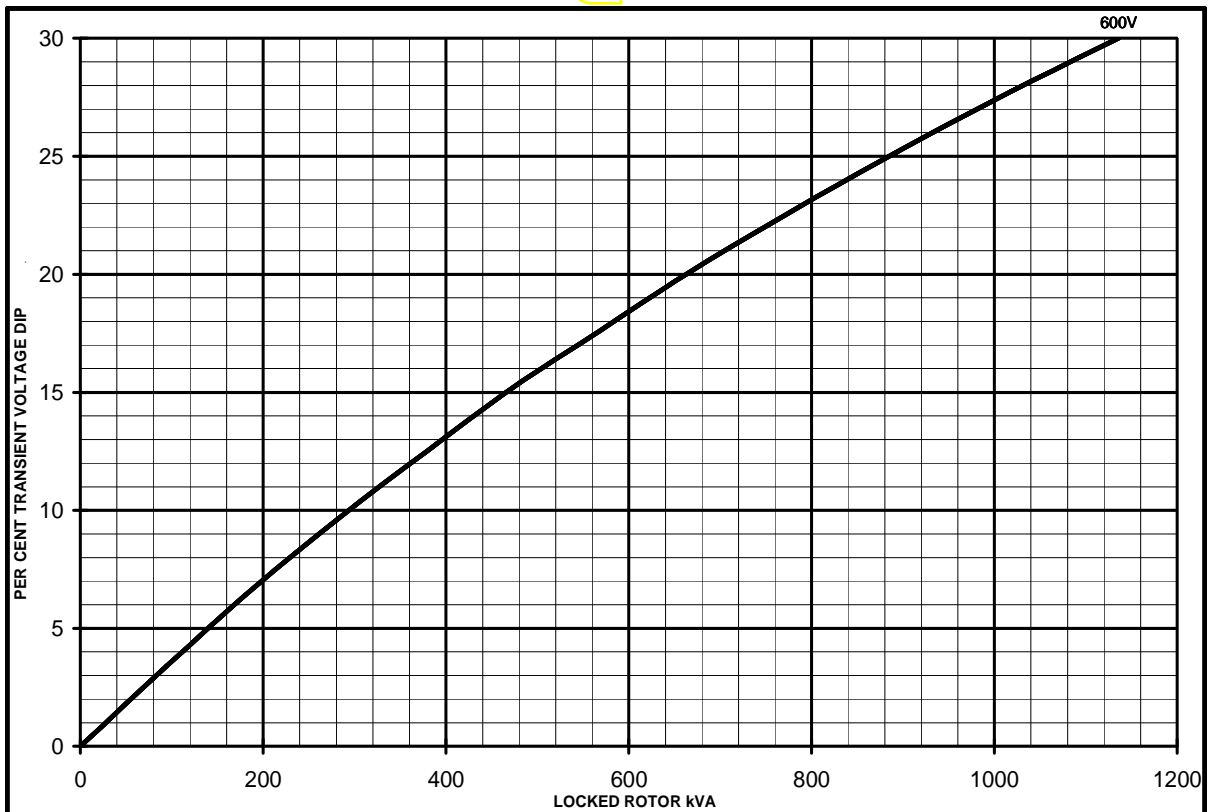

HCI434E/444E
Winding 17

STAMFORD

THREE PHASE EFFICIENCY CURVES

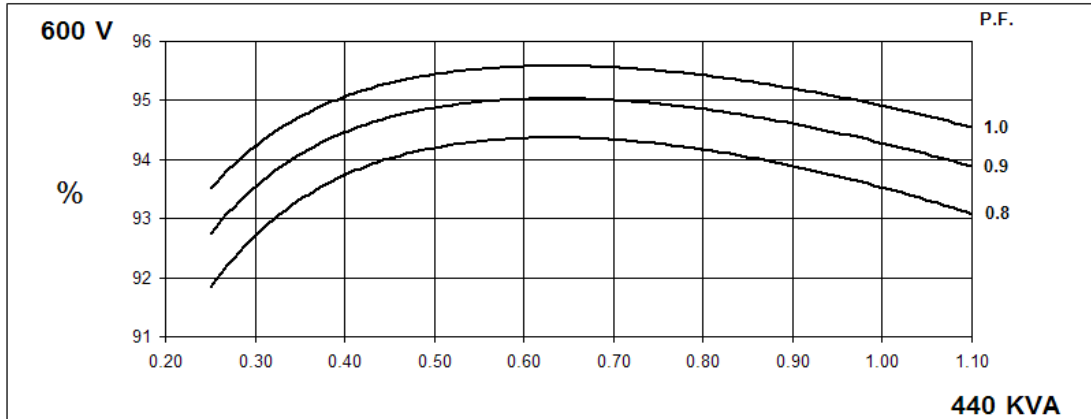

Three-phase Short Circuit Decrement Curve. No-load Excitation at Rated Speed Based on star (wye) connection.

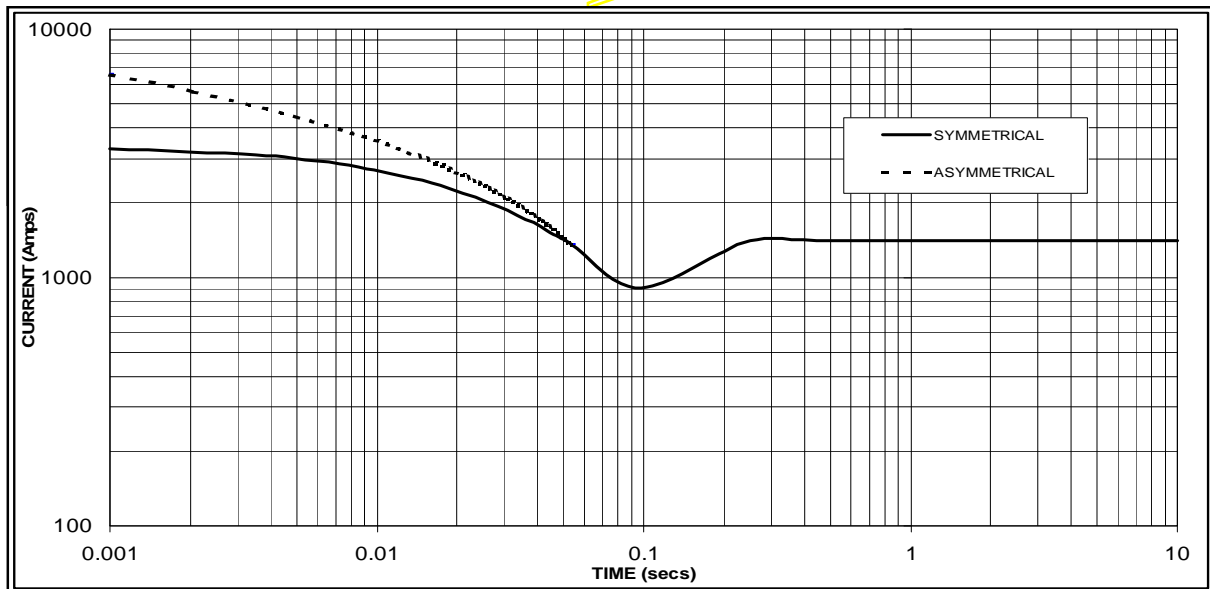

Sustained Short Circuit = 1400 Amps

Note

The following multiplication factor should be used to convert the values from curve for the various types of short circuit :

	3-phase	2-phase L-L	1-phase L-N
Instantaneous	x 1.00	x 0.87	x 1.30
Minimum	x 1.00	x 1.80	x 3.20
Sustained	x 1.00	x 1.50	x 2.50
Max. sustained duration	10 sec.	5 sec.	2 sec.

All other times are unchanged

HCI434E/444E

Winding 17 / 0.8 Power Factor

STAMFORD

60Hz

RATINGS

Class - Temp Rise	Cont. F - 105/40°C	Cont. H - 125/40°C	Standby - 150/40°C	Standby - 163/27°C
Series Star (V)	600	600	600	600
Parallel Star (V)	300	300	300	300
Series Delta (V)	346	346	346	346
kVA	400	440	460	475
kW	320	352	368	380
Efficiency (%)	93.9	93.5	93.3	93.2
kW Input	341	376	394	408

APPROVED

DIMENSIONS

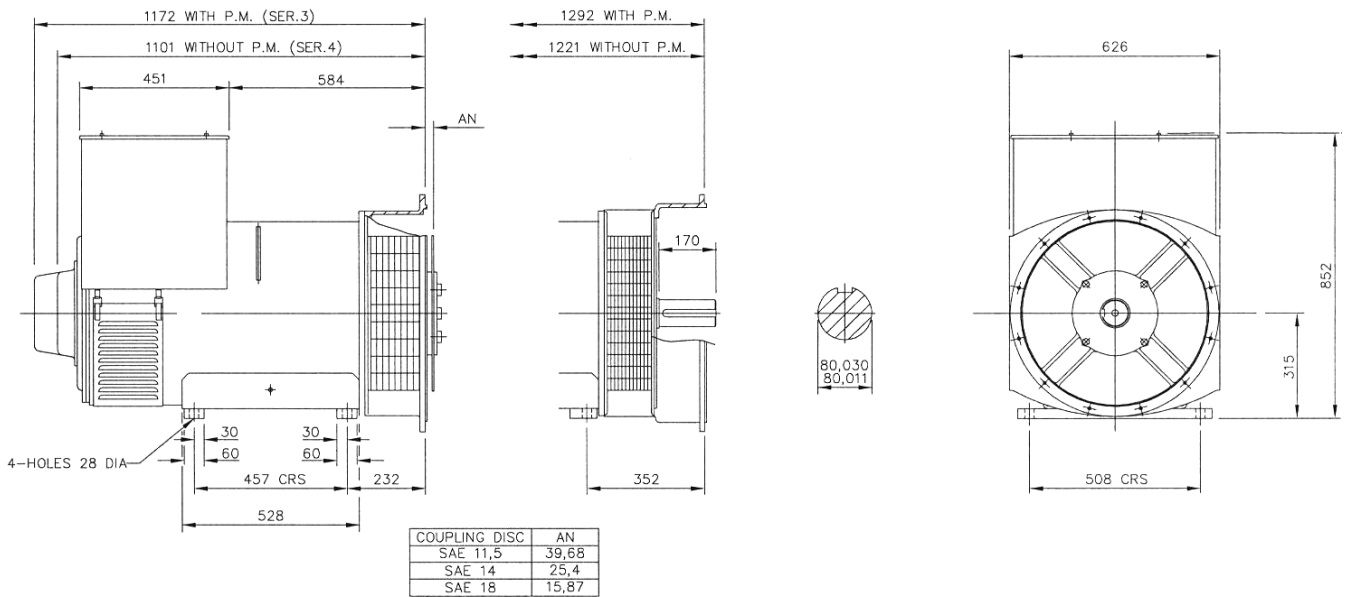

APPROVED DOCUMENT

STAMFORD

Head Office Address:
Barnack Road, Stamford
Lincolnshire, PE9 2NB
United Kingdom
Tel: +44 (0) 1780 484000
Fax: +44 (0) 1780 484100

www.cumminsgeneratortechnologies.com

Copyright 2010, Cummins Generator Technologies Ltd, All Rights Reserved
Stamford and AvK are registered trade marks of Cummins Generator Technologies Ltd
Cummins and the Cummins logo are registered trade marks of Cummins Inc.



A highly advanced integrated genset control system, this device provides genset control, transfer switch control, metering, protection, and programmable logic in a simple, easy-to-use, reliable, rugged, and cost effective package.

FEATURES

- Generator metering (includes three-phase mains)
- Engine and generator protection: 27, 32R, 40Q, 59, 810/U
- Optional enhanced generator protection: 47, 51, 78, and 81ROCOF
- Load sharing and generator sequencing (via LSM-200 Load Share Module)
- Var sharing over Ethernet (via LSM-200)
- BESTCOMSP^{Plus}® Software
 - Programming and setup
 - Intuitive and powerful
 - Remote control and monitoring
 - Programmable logic
 - USB communications
- Automatic transfer switch control
- Automatic synchronizer (optional)
- Exercise timer
- SAE J1939 engine ECU communications
- Automatic generator configuration detection
- Expandable functionality via add-on modules
 - [LSM-200 Load Share Module](#)
 - [CEM-200 Contact Expansion Module](#)
 - [AEM-200 Analog Expansion Module](#)
- Multilingual capability
- Remote communications to Basler's RDP-110 (remote display panel)
- Sixteen programmable contact inputs
- Up to 15 contact outputs: 3 contacts rated for 30 Adc and up to 12 programmable contacts rated for 2 Adc

BENEFITS

- Provides integrated engine-genset control, protection, and metering in a single package.
- The Offline Simulator, provided in BESTlogic™ Plus, helps test and troubleshoot logic without the need for expensive hardware.
- Flexible programmable logic and programmable I/O make it easy to expand the DGC-200's inputs and outputs with the CEM-200 (Contact Expansion Module) and the AEM-200 (Analog Expansion Module). This saves time and money by eliminating unnecessary external PLCs and control relaying.

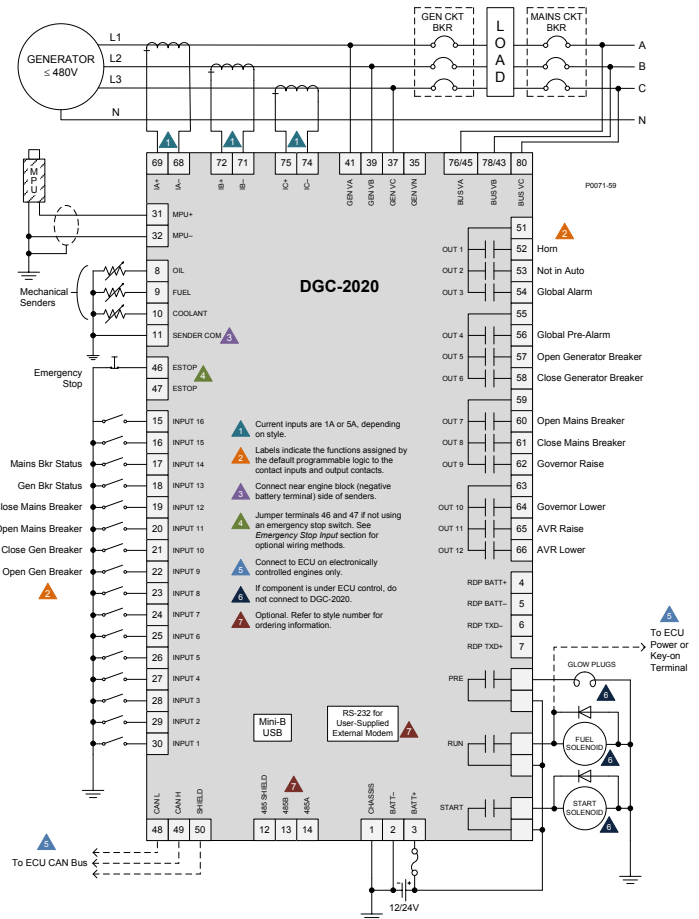

Figure 1 - DGC-200 Connection Diagram for a Typical Application

Visit www.basler.com
FOR ADDITIONAL INFORMATION.

SPECIFICATIONS

Power Supply

Nominal:	12 or 24 Vdc
Range:	6 to 32 Vdc
Battery Ride Through:	Starting at 10 Vdc, withstands cranking ride-through down to 0 V for 50 ms

Power Consumption

Sleep Mode:	5 W
Normal Operational Mode:	7.9 W
Maximum:	14.2 W

Current Sensing

1 A Sensing:	0.02 to 1.0 Aac, continuous 2 Aac for 1 second
5 A Sensing:	0.1 to 5.0 Aac, continuous 10 Aac for 1 second
Burden:	1 VA

Voltage Sensing

Range:	12 to 576 Vrms L-L
Frequency Range:	10 to 72 Hz for 50/60 Hz style, 10 to 480 Hz for 400 Hz style
Burden:	1 VA
One-second Rating:	720 Vrms

Contact Sensing

Contact Inputs (16):	Accepts normally open (N.O.), Dry Contacts, programmable
Emergency Stop:	Normally closed (N.C.), Dry Contact

Engine Speed Sensing

Magnetic Pickup:	
Voltage Range:	6 to 70 Vpp
Frequency Range:	32 to 10,000 Hz
Generator Frequency:	
Generator Voltage Range:	12 to 576 Vrms
Via ECU over J1939	

Resistive Senders

Fuel Level Sender:	0 to 250 Ω nominal
Coolant Temp Sender:	10 to 2,750 Ω nominal
Oil Pressure Sender:	0 to 250 Ω nominal

Output Contacts

Fuel Solenoid, Engine Crank, Pre-Start Relays Rating:	30 Adc at 28 Vdc- make, break, and carry
Programmable Relays:	Up to 12
Rating:	2 Adc at 28 Vdc- make, break, and carry

Protection

Generator:	27, 32R, 40Q, 59, 81O/U (standard) 47, 51, 78, 81 ROCOF (optional)
Engine:	Oil pressure, coolant temperature, overcrank, ECU-specific elements, and diagnostic reporting.

Agency Approvals

- CSA certified, NFPA compliant, CE compliant,
- UL recognized (Hazardous Location certification available upon request), EAC certified

Communication

USB Port:	USB 2.0, Mini-B jack
RS-485 (optional):	9600 baud, 8 data bits, no parity
RDP-110 (optional):	4,000 ft (1,219 m) max wire length, 20 AWG (0.52 mm ²) min wire size
Modem (optional):	DB-9 connector (male)
CAN bus:	250 kb/s communication rate, 1.5 to 3 Vdc differential bus

Environmental

Operating Temp:	-40°C to 70°C (-40°F to 158°F)
Storage Temp:	-40°C to 85°C (-40°F to 185°F)
Humidity:	IEC 68-2-38
Salt Fog:	ASTM B 17-73, IEC 68-2-11
Ingress Protection:	IEC IP54 for front panel
Shock:	15 G in three perpendicular planes
Vibration:	
5 to 29 Hz:	1.5 G peak
29 to 52 Hz:	0.036" (0.914 mm) double amplitude
52 to 500 Hz:	5 G peak

Physical

Weight:	4.4 lb (2 kg)
Dimensions (WxHxD):	11.77 x 8.27 x 2.69 inches (299 x 210 x 69 mm)

For complete specifications, download the instruction manual at www.basler.com.

STYLE CHART

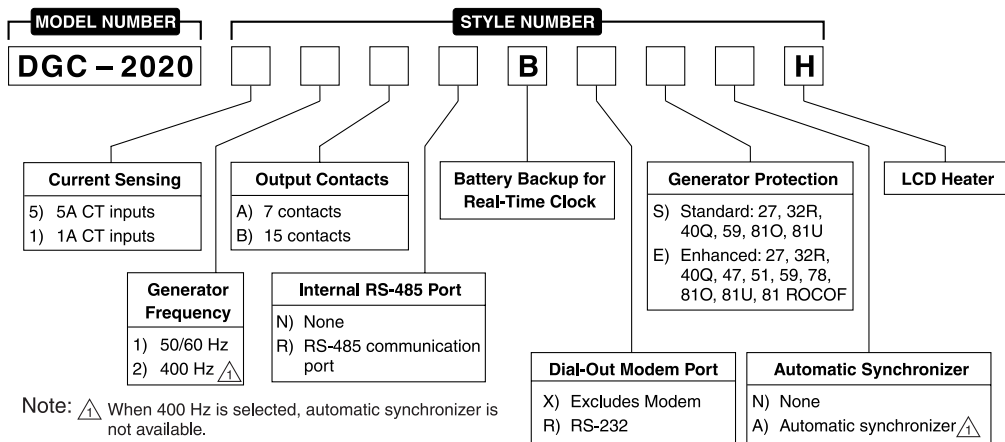

RELATED PRODUCTS

- [BE1-11g Generator Protection System](#)
 - A complete generator protection system.
- [DECS-250 Digital Excitation Control System](#)
 - Total control in a compact package provides precise voltage, var and power factor regulation, exceptional system response, and generator protection.

ACCESSORIES

- [AEM-2020 Analog Expansion Module](#)
 - Easily increases the functionality by seamlessly adding analog inputs and outputs.
- [CEM-2020, CEM-2020H Contact Expansion Module](#)
 - Each module adds 10 inputs and up to 24 outputs that are easily programmed through BESTCOMSPUs[®] for easy integration into the system.
- [LSM-2020 Load Share Module](#)
 - The simple-to-use LSM-2020 easily adds paralleling capabilities with little effort and expense.
- [RDP-110 Remote Display Panel](#)
 - Provides remote alarm and pre-alarm indication and annunciation of system status, easily meeting the annunciation requirements of NFPA-110 applications.



12570 State Route 143, Highland, Illinois 62249-1074 USA
Tel +1 618.654.2341 Fax +1 618.654.2351
email: info@basler.com www.basler.com

P.A.E. Les Pins, 67319 Wasselonne Cedex, FRANCE
Tel +33 3.88.87.1010 Fax +33 3.88.87.0808
e-mail: franceinfo@basler.com

No. 59 Heshun Road Loufeng District (N),
Suzhou Industrial Park, 215122, Suzhou, P.R.China
Tel +86(0)512.8227.2888 Fax +86(0)512.8227.2887
e-mail: chinainfo@basler.com

111 North Bridge Road #15-06 Peninsula Plaza
Singapore 179098
Tel +65 68.44.6445 Fax +65 68.44.8902
e-mail: singaporeinfo@basler.com

Tmax-Molded Case Circuit Breakers

T6 800A Frame

AC Circuit Breakers and Switches

DC Circuit Breakers and Switches

3 and 4 Pole

Motor Circuit Protectors

Higher Performances in Less Space

Field Installable Accessories and Trip Units



Dimensions 3P Fixed Version 10.55H x 8.26W x 4.07D

Weight 20.9 (lbs)

Compliance with Standards

UL 489

CSA C22.2 No.5.1

IEC 60947-2

Standards

EC directive:

– “Low Voltage Directives” (LVD) no. 73/23 EEC

– “Electromagnetic Compatibility Directive” (EMC) no.89/336 EEC

The ABB Quality System complies with the international ISO 9001 - 2000 Standard (model for quality assurance in design, development, construction, and installation and service) and with the equivalent European EN ISO 9001 and Italian UNI EN ISO 9001 Standards

Interrupting ratings (RMS sym. kAmps)

		T6			
Continuous Current Rating		800			
Number of Poles		3-4			
		N	S	H	L
AC					
240V		65	100	200	200
480V		35	50	65	100
600V		20	25	35	42
DC*					
500V	2 poles in series	35	35	50	65
600V	3 poles in series	20	20	35	50

*Thermal Magnetic Trip Only

Company Quality Systems and Environmental Systems

The new Tmax series has a hologram on the front, obtained using special anti-imitation techniques, which guarantees the quality and that the circuit breaker is an original ABB product.

Attention to protection of the environment and to health and safety in the work place is another priority commitment for ABB and, as confirmation of this, the company environmental management system has been certified by RINA in 1997, in conformity with the international ISO 14001 Standard. This certification has been integrated in 1999 with the Management System for Health and Safety in the workplace, according to OHSAS 18001 (British Standards), obtaining one of the first certification of integrated management System, QES (Quality, Environment,

Safety) issued by RINA. ABB - the first industry in the electro-mechanical section in Italy to obtain this recognition - thanks to a revision of the production process with an eye to ecology has been able to reduce the consumption of raw materials and waste from processing by 20%. ABB's commitment to safeguarding the environment is also shown in a concrete way by the Life Cycle Assessments of its products carried out directly by the ABB Research and Development in collaboration with the ABB Research Center. Selection of materials, processes and packing materials is made optimizing the true environmental impact of the product, also foreseeing the possibility of its being recycled.

Mounting

Fixed
Drawout

Connections

Busbar connection or compression lugs
Pressure-type terminals for bare cables
Rear connections

Trip Unit

TMA thermal magnetic trip units, with adjustable thermal threshold ($I_1 = 0.7 \dots 1 \times I_n$) and adjustable magnetic threshold ($I_3 = 5 \dots 10 \times I_n$).

PR221DS, PR222DS/P, and PR222DS/PD-A electronic trip unit

Auxiliary Devices for Indication and Control

- Auxiliary contacts - AUX
- Undervoltage release - UVR
- Shunt trip - SOR
- Terminal covers
- Front for lever operating mechanism - FLD
- Direct rotary handle - RHD
- Stored energy motor operator - MOE
- Key lock - KLF
- Early auxiliary contact - AUE
- Transmitted rotary handle - RHE
- Front extended terminal - EF
- Front terminal for copper-aluminum - FC CuAl
- Front extended spread terminal - ES
- Rear orientated terminal - R
- Phase separators
- Residual current relay (IEC Only)



ABB Inc.

1206 Hatton Road
Wichita Falls, TX 76302
For more information and
the location of your local
field office please go to
www.abb-control.com

Tmax-Molded Case Circuit Breakers

T7 1200A Frame

AC Circuit Breakers and Switches

3 and 4 Pole

Motor Circuit Protectors

Higher Performances in Less Space

Field Installable Accessories and Trip Units



Dimensions 3P Fixed Version 10.55H x 8.26W x 6.06D

Weight 21.4 (lbs)

Compliance with Standards

UL 489

CSA C22.2 No.5.1

IEC 60947-2

Standards

EC directive:

– “Low Voltage Directives” (LVD) no. 73/23 EEC

– “Electromagnetic Compatibility Directive” (EMC) no.89/336 EEC

The ABB Quality System complies with the international ISO 9001 - 2000 Standard (model for quality assurance in design, development, construction, and installation and service) and with the equivalent European EN ISO 9001 and Italian UNI EN ISO 9001 Standards

Interrupting ratings (RMS sym. kAmps)		T7		
Continuous Current Rating		1200		
Number of Poles		3-4		
		S	H	L
AC				
	240V	65	100	150
	480V	50	65	100
	600V	25	50	65

Company Quality Systems and Environmental Systems

The new Tmax series has a hologram on the front, obtained using special anti-imitation techniques, which guarantees the quality and that the circuit breaker is an original ABB product.

Attention to protection of the environment and to health and safety in the work place is another priority commitment for ABB and, as confirmation of this, the company environmental management system has been certified by RINA in 1997, in conformity with the international ISO 14001 Standard. This certification has been integrated in 1999 with the Management System for Health and Safety in the workplace, according to OHSAS 18001 (British Standards), obtaining one of the first certification of integrated management System, QES (Quality, Environment,

Safety) issued by RINA. ABB - the first industry in the electro-mechanical section in Italy to obtain this recognition - thanks to a revision of the production process with an eye to ecology has been able to reduce the consumption of raw materials and waste from processing by 20%. ABB's commitment to safeguarding the environment is also shown in a concrete way by the Life Cycle Assessments of its products carried out directly by the ABB Research and Development in collaboration with the ABB Research Center. Selection of materials, processes and packing materials is made optimizing the true environmental impact of the product, also foreseeing the possibility of its being recycled.

Mounting

Fixed
Drawout

Connections

Busbar connection or compression lugs
Pressure-type terminals for bare cables
Rear connections

Trip Unit

PR231/P, PR232/P, PR331DS, and PR332DS/P electronic trip unit

Auxiliary Devices for Indication and Control

- Auxiliary contacts - AUX
- Undervoltage release - UVR
- Shunt trip - SOR
- Terminal covers
- Padlock provision - PLL
- Direct rotary handle - RHD
- Key lock - KLF
- Early auxiliary contact - AUE
- Transmitted rotary handle - RHE
- Front extended terminal - EF
- Front terminal for copper-aluminum - FC CuAl
- Front extended spread terminal - ES
- Rear orientated terminal - R
- Phase separators
- Residual current relay (IEC Only)



ABB Inc.

1206 Hatton Road
Wichita Falls, TX 76302
For more information and
the location of your local
field office please go to
www.abb-control.com

Digital Linear Chargers

Specifications

- Waterproof, shock-and vibration-resistant aluminum construction
- Saltwater tested and fully corrosion-resistant
- Short circuit, reverse polarity, and ignition protected
- For use with 12V/6 cell batteries that are flooded/wet cell, maintenance free or starved electrolyte (AGM) only
- FCC compliant
- UL listed to marine standard 1236
- 3 year warranty
- Replaces all existing current on-board chargers (excluding portables)
- No Price Increase
- Availability: November 2010



DIGITAL LINEAR ON-BOARD CHARGERS

PRODUCT CODE	PRODUCT DESCRIPTION
1821065	MK 106D (1 bank x 6 amps)
1821105	MK-110D (1 bank x 10 amps)
1822105	MK-210D (2 bank x 5 amps)
1823155	MK-315D (3 bank x 5 amps)
1822205	MK-220D (2 bank x 10 amps)
1823305	MK-330D (3 bank x 10 amps)
1824405	MK-440D (4 bank x 10 amps)
1822305	MK-230D (2 bank x 15 amps)
1823455	MK-345D (3 bank x 15 amps)
1824605	MK-460D (4 bank x 15 amps)

Digital Linear Chargers

Specifications (cont.)

- New 4-color package design

minnkotamotors.com

MINN-KOTA

ON-BOARD MARINE BATTERY CHARGER

DIGITALLY CONTROLLED 2X FASTER CHARGING PROTECTS BATTERIES

Digital CONTROL

MK 210D

2 CHARGING BANKS
5 AMPS PER BANK
10 AMPS TOTAL OUTPUT

10 AMPS

UL FC

CHARGING TECHNOLOGY

CHARGING TECHNOLOGY

DIGITALLY CONTROLLED.
Microprocessor design protects your batteries so you can stay on the water longer. It monitors temperature and state of charge to create a faster, regulated, more precise charge. Also includes automatic shut-off when charging is complete to extend battery life.

DIGITALLY CONTROLLED.
Microprocessor design protects your batteries so you can stay on the water longer. It monitors temperature and state of charge to create a faster, regulated, more precise charge. Also includes automatic shut-off when charging is complete to extend battery life.

ENHANCED STATUS CODES.
Provides comprehensive feedback on charge stage, maintenance mode status, error notification and full charge.

ENHANCED STATUS CODES.
Provides comprehensive feedback on charge stage, maintenance mode status, error notification and full charge.

MULTI-STAGE CHARGING.
Delivers a fast, precise charge profile by automatically controlling current and voltage without overcharging your batteries.

MULTI-STAGE CHARGING.
Delivers a fast, precise charge profile by automatically controlling current and voltage without overcharging your batteries.

AUTOMATIC TEMPERATURE COMPENSATION.
Adjusts output voltage based on ambient temperature to ensure a full charge and protect your batteries.

AUTOMATIC TEMPERATURE COMPENSATION.
Adjusts output voltage based on ambient temperature to ensure a full charge and protect your batteries.

MULTI-STAGE CHARGING
BULK ABSORPTION MAINTENANCE

AMPS & VOLTS

TIME (THREE STAGE CHARGER)

BATTERY CHARGER TEMPERATURE COMPENSATION

absorption voltage (output voltage)

BATTERY VOLTAGE

BATTERY TEMPERATURE (degrees F)

2010



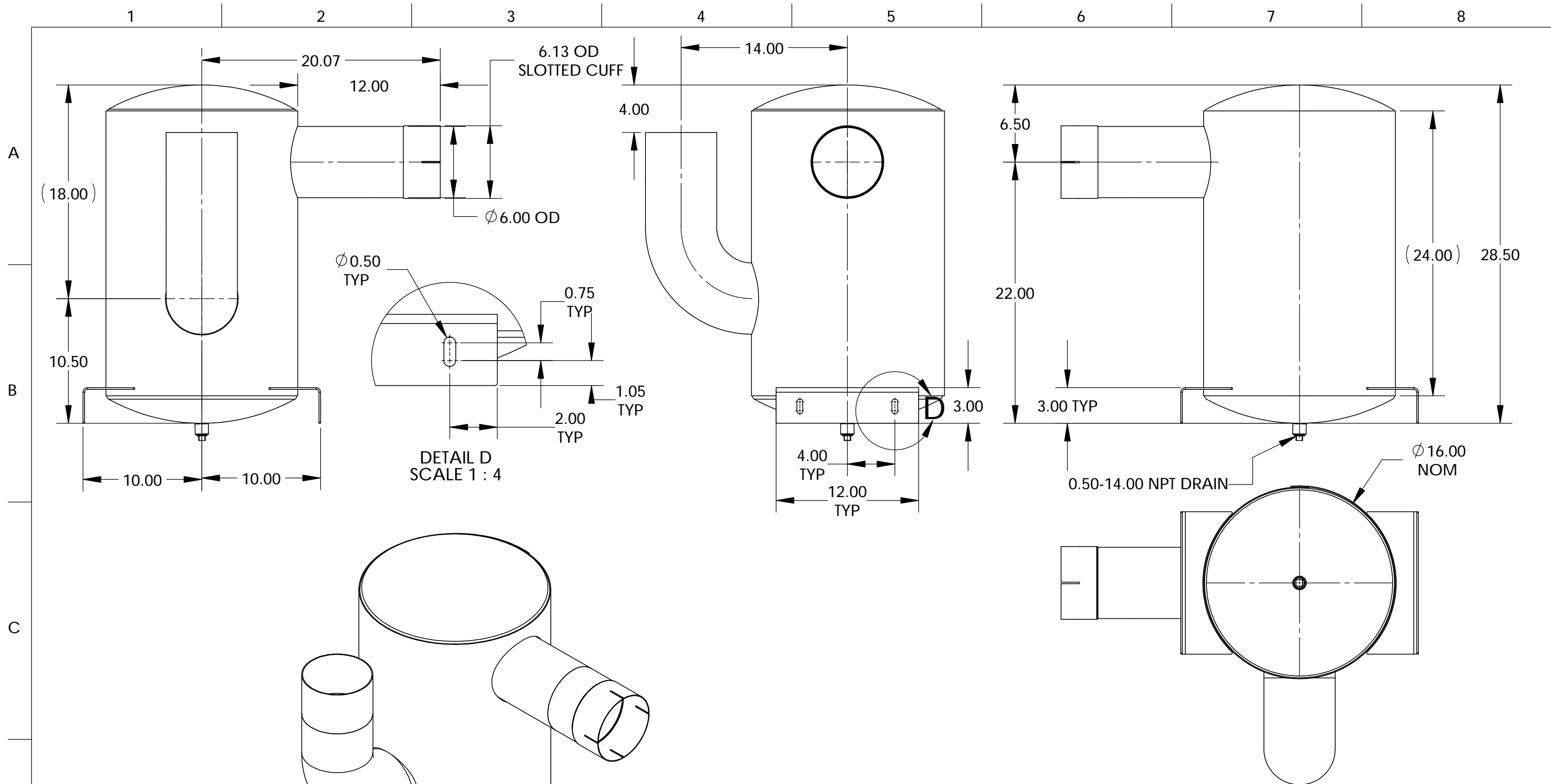

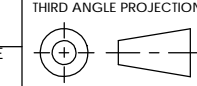
ENGINE INFORMATION		SILENCER INFORMATION		DRAWN BY	DATE			
ENGINE MAKE	MTU	RESONATOR FREQUENCY	---	CB	08/23/2017			
ENGINE MODEL	10V1600	RESONATOR ALPHA	---	CHECKED BY	DATE	DESCRIPTION SIL: COMP CRIT CS S-E 6.00-6.00 Ø16.00 28.50 OAL F:6.50 --- CONSTRUCTION MATERIAL CS		
DISPLACEMENT	854	SILENCER Km	---	CB	09/15/2017			
EXHAUST FLOW	3623	SILENCER IL	---	MANUFACTURING	DATE	WEIGHT (LBS) 80 SHEET 3 OF 3 FINISH HIGH TEMP BLACK PAINT		
EXHAUST TEMPERATURE	892	TOLERANCES DO NOT APPLY TO GAGE THICKNESS OR COMMERCIAL FEATURES		CB	09/15/2017			
MAX BACK PRESSURE	60	TOLERANCES UNLESS OTHERWISE SPECIFIED		X = ±0.25 ALL ANGLES .XX = ±0.125 ±1° .XXX = ±0.0625 .XXXX = ±0.03125		PART NUMBER 500-008549 SCALE (DO NOT SCALE) SHEET SIZE 1:8 B		
RAW SOUND PRESSURE	---	THIRD ANGLE PROJECTION		 This drawing and the information contained is confidential and the property of Bergari Solutions, LLC. None of this information is to be copied or shared in any form without the express permission from Bergari Solutions, LLC.				
CUSTOMER	---	CUSTOMER P7/N	---	REV.	BY	DATE	DESCRIPTION	ECO
---	---	---	---	A	CB	09/15/2017	OVERALL LENGTH EXTENDED	---

OUTLINE DIMENSIONS FOR SPVD-3500 OPEN

TOP VIEW

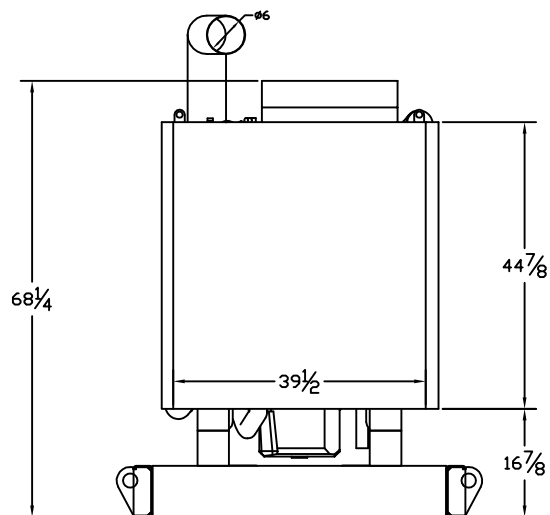
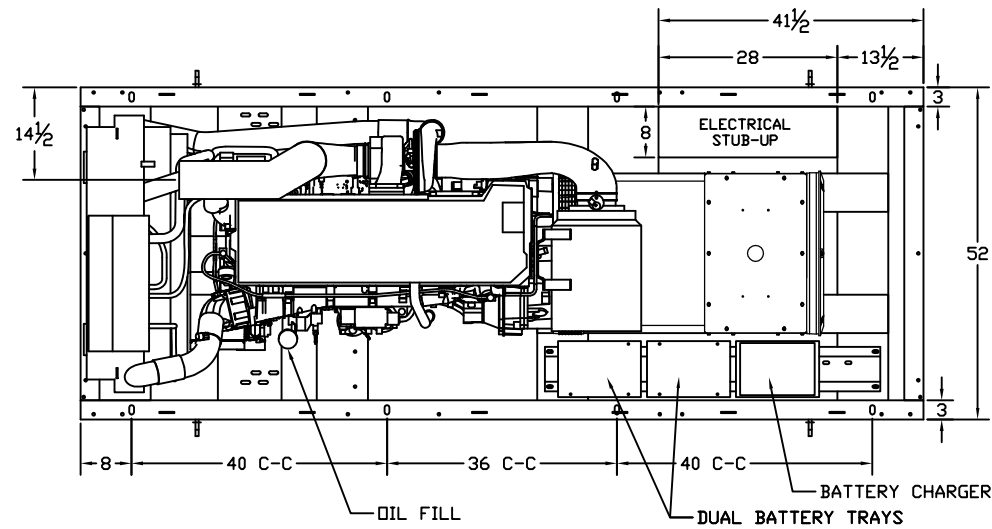

RADIATOR END VIEW

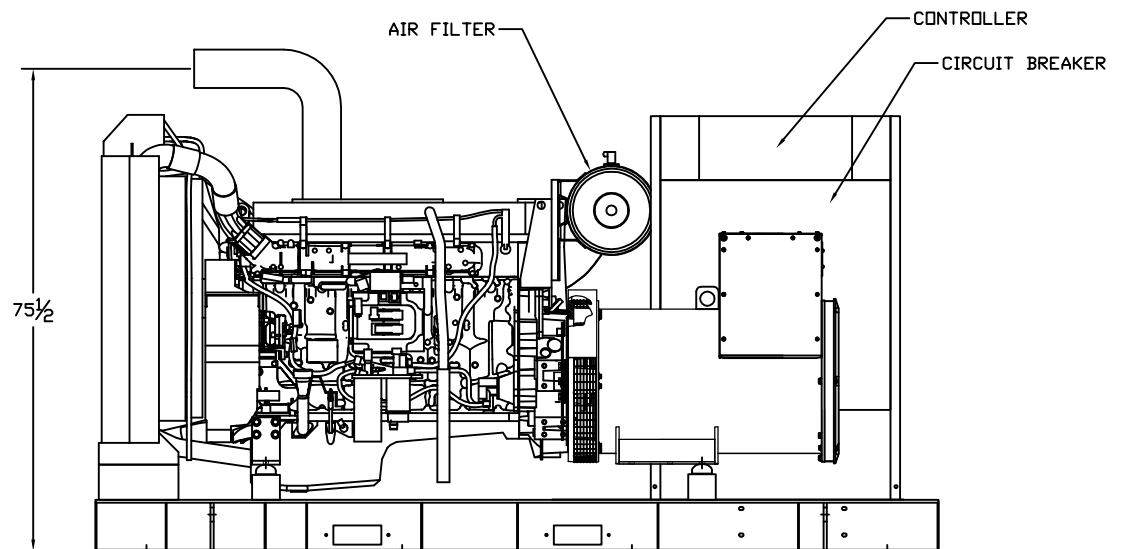

RIGHT SIDE VIEW

OUTLINE DIMENSIONS FOR SPVD 250 - 400 KW LEVEL 2 ENCLOSURE (HINGED DOORS)

TOP VIEW

<GEN-SET HAS (6) DOORS, (3) SHOWN OPEN ARE TYPICAL FOR BOTH SIDES>

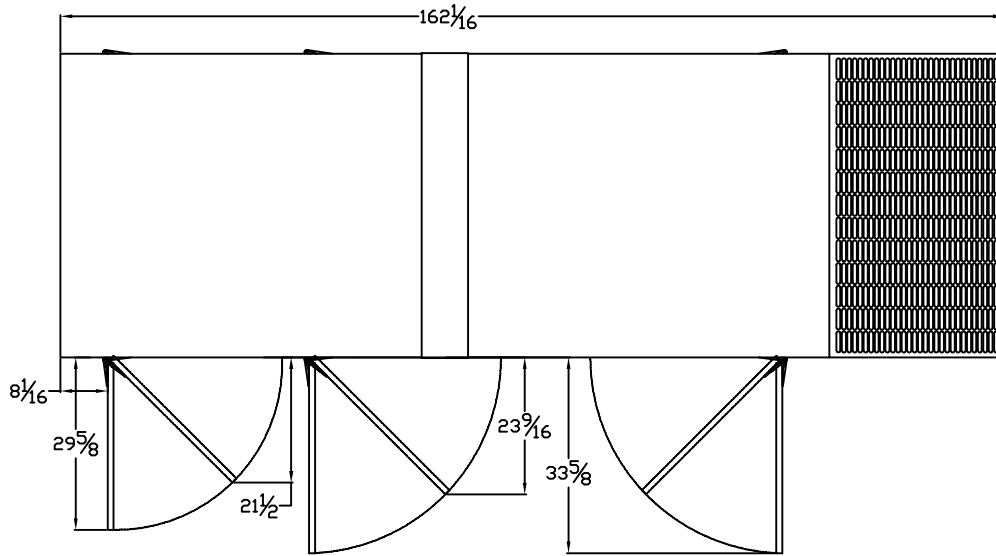

FRAME VIEW

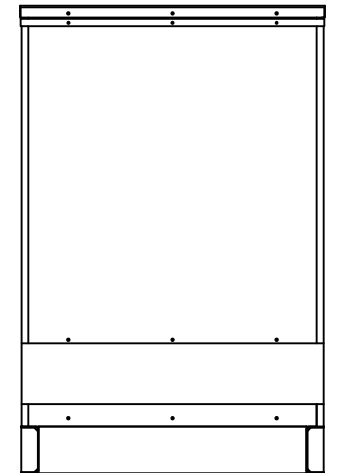
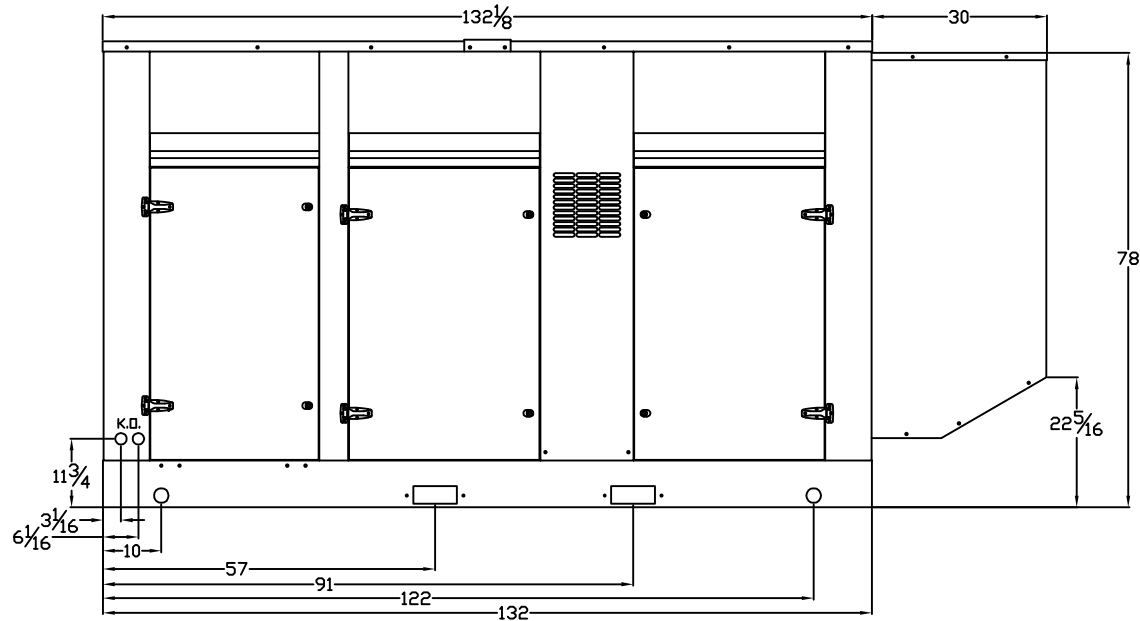
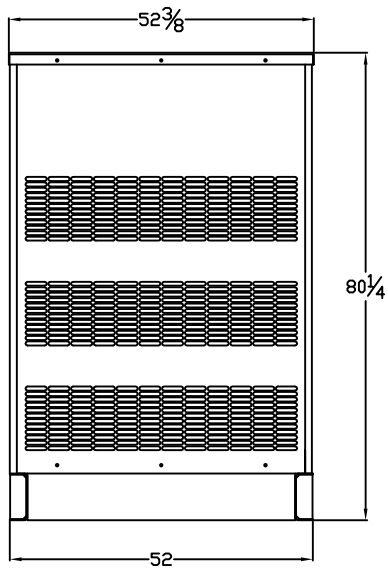
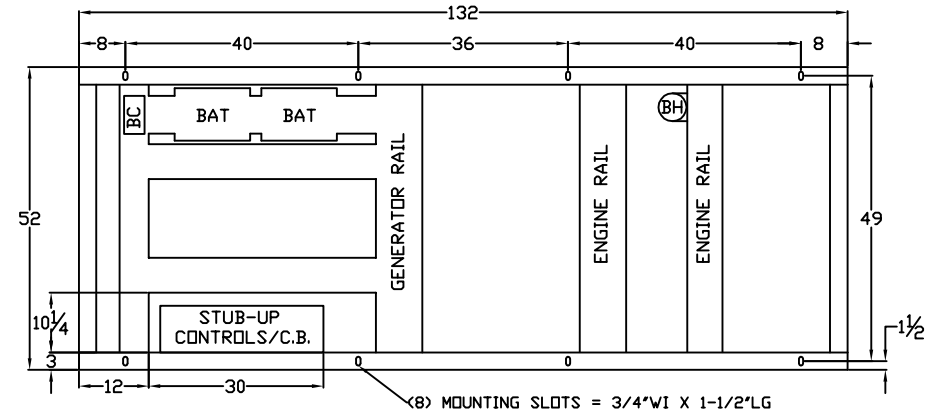

GENERATOR END VIEW

SIDE VIEW

RADIATOR END VIEW