



GILLETTE GENERATORS

LIQUID COOLED DIESEL ENGINE GENERATOR SET

60 HZ MODEL
SPVD-6000

Model	HZ	STANDBY
		120°C RISE
SPVD-6000-60 HERTZ	60	600



All generator sets are USA prototype built and thoroughly tested. Production models are USA factory built and 100% load tested.



UL2200, UL1446, UL508, UL142, UL498



NFPA 110, 99, 70, 37

All generator sets meet NFPA-110 Level 1, when equipped with the necessary accessories and installed per NFPA standards.



NEC 700, 701, 702, 708



NEMA ICS10, MG1, ICS6, AB1



ANSI C62.41, 27, 59, 32, 480, 40Q, 81U, 360-05



ASCE 7-05 & 7-10

All generator sets meet 180 MPH rating.



EPA 40CFR Part 60, 1048, 1054, 1065, 1068

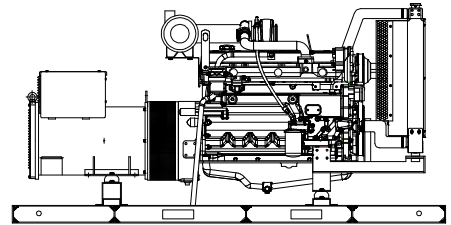

“OPEN” GEN-SET

There is no enclosure, so gen-set must be placed within a weather protected area, uninhabited by humans or animals, with proper ventilation. Silencer not supplied, as installation requirements are not known. However, this item is available as optional equipment.

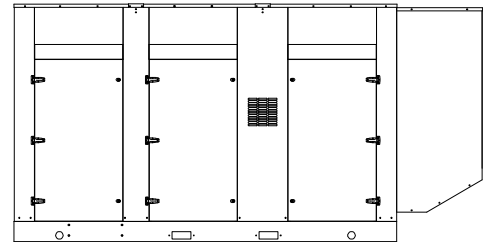

“LEVEL 2” HOUSED GEN-SET

Full aluminum weather protection and superior sound attenuation for specific low noise applications. Critical grade muffler is standard.

GENERATOR RATINGS

GENERATOR MODEL	VOLTAGE		PH	HZ	120°C RISE STANDBY RATING		POWER LEAD CONNECTIONS
	L-N	L-L			KW/KVA	AMP	
SPVD-6000-3-2	120	208	3	60	600/750	2084	12 LEAD LOW WYE
SPVD-6000-3-3	120	240	3	60	600/750	1806	12 LEAD HIGH DELTA
SPVD-6000-3-4	277	480	3	60	600/750	903	12 LEAD HIGH WYE
SPVD-6000-3-5	127	220	3	60	600/750	1970	12 LEAD LOW WYE
SPVD-6000-3-16	346	600	3	60	600/750	722	4 LEAD HIGH WYE

RATINGS: All single phase gen-sets are dedicated 4 lead windings, rated at unity (1.0) power factor. All three phase gen-sets are 12 lead windings, rated at .8 power factor. 120° C “STANDBY RATINGS” are strictly for gen-sets that are used for back-up emergency power to a failed normal utility power source. This standby rating allows varying loads, with no overload capability, for the entire duration of utility power outage. All gen-set power ratings are based on temperature rise measured by resistance method as defined by MIL-STD 705C and IEEE STD 115, METHOD 6.4.4. All generators have class H (180°C) insulation system on both rotor and stator windings. All factory tests and KW/KVA charts shown above are based 120°C (standby) R/R winding temperature, within a maximum 40°C ambient condition. Generators operated at standby power ratings must not exceed the temperature rise limitation for class H insulation system, as specified in NEMA MG1-22.40. Specifications & ratings are subject to change without prior notice.

APPLICATION & ENGINEERING DATA FOR MODEL SPVD-6000-60 HZ

GENERATOR SPECIFICATIONS

Manufacturer.....Stamford Electric Generators
Model & Type.....HCI634G-311, 4 Pole, 12 Lead, Three Phase
.....HCI534E-311, 4 Pole, 12 Lead, 480V, Three Phase
.....HCI534F-17, 4 Pole, 6 Lead, 600V, Three Phase
Exciter.....Brushless, shunt excited
Voltage Regulator.....Solid State, HZ/Volts
Voltage Regulation.....½%, No load to full load
Frequency.....60 HZ
Frequency Regulation.....± ½% (1/2 cycle, no load to full load)
Unbalanced Load Capability.....100% of standby amps
One Step Load Acceptance.....100% of nameplate rating
Total Stator and Load Insulation.....Class H, 180°C
Temperature Rise.....120°C R/R, standby rating @ 40°C amb.
3 Ø Motor Starting @ 30% Voltage Dip (208-240V)...1500 kVA
3 Ø Motor Starting @ 30% Voltage Dip (480V).....2140 kVA
3 Ø Motor Starting @ 30% Voltage Dip (600V).....2140 kVA
Bearing.....1, Pre-lubed and sealed
Coupling.....Direct flexible disc.
Total Harmonic Distortion.....Max 3½% (MIL-STD705B)
Telephone Interference Factor.....Max 50 (NEMA MG1-22)
Deviation Factor.....Max 5% (MIL-STD 405B)
Alternator.....Self ventilating and drip-proof
Ltd. Warranty Period.....24 Months from start-up date or
.....1000 hours use, first to occur.

GENERATOR FEATURES

- World Renown Stamford Electric Generator having UL-1446 certification.
- Full generator protection with **Basler DGC-2020** controller, having UL-508 certification.
- Automatic voltage regulator with over-excitation, under-frequency compensation, under-speed protection, and EMI filtering. Entire solid-state board is encapsulated for moisture protection.
- Generator power ratings are based on temperature rise, measured by resistance method, as defined in MIL-STD 705C and IEEE STD 115, Method 6.4.4.
- Power ratings will not exceed temperature rise limitation for class H insulation as per NEMA MG1-22.40.
- Insulation resistance to ground, exceeds 1.5 meg-ohm.
- Stator receives 2000 V. hi-potential test on main windings, and rotor windings receive a 1500 V. hi-potential test, as per MIL-STD 705B.
- Full amortisseur windings with UL-1446 certification.
- Complete engine-generator torsional acceptance, confirmed during initial prototype testing.
- Full load testing on all engine-generator sets, before shipping.

ENGINE SPECIFICATIONS AND APPLICATIONS DATA

ENGINE

Manufacturer.....VOLVO-PENTA
Model and Type.....TWD1643GE, 4 cycle, liquid Cooled
Aspiration.....Turbo After Cooler, H2O to Air
Charged Air Cooled System.....H2O to Air
Cylinder Arrangement.....6 Cylinders, In-Line
Displacement Cu. In. (Liters).....984 (16.1)
Bore & Stroke in (Cm).....5.67 x 6.50 (14.4 x 16.5)
Compression Ratio.....16.5:1
Main Bearings.....Tin Overlay with Babbit Backing
Cylinder Head.....Cast Iron with overhead Cam
Pistons.....Aluminum Alloy with Graphite Coating
Crankshaft.....Induction Hardened, Heat Treated Forged
Valves.....Heat Treated and Hardened Exhaust Valve
Governor.....Electronic, EMS 2.2
Frequency Regulation.....± 1/4%
Air Cleaner.....Dry, Replaceable Cartridge
Engine Speed.....1800 rpm
Max Power, bhp (kwm) Standby.....917 (674)
BMEP: psi (MPa) Standby.....369 (2.5)
Ltd. Warranty Period.....2 Year or 1000 hrs, first to occur

FUEL SYSTEM

Type.....Diesel Fuel Oil (ASTM No. 2-D)
Combustion System.....Direct Injection
Fuel Injection Pump.....Electronic, Delphi E3
24 VDC Coolant heaters.....Optional Equipment
Fuel Filter.....Yes with Water Separator

FUEL CONSUMPTION

GAL/HR (LITER/HR)	STANDBY
100% LOAD	40.8 (154.4)
75% LOAD	29.7 (112.4)
50% LOAD	20.0 (75.7)

OIL SYSTEM

Type.....Full Pressure
Oil Pan Capacity qt. (L).....50.7 (48)
Oil Pan Cap. W/ filter qt. (L).....44.3 (42)
Oil Filter.....3, Replaceable Cartridge type

ELECTRICAL SYSTEM

Ignition System.....Electronic
Eng. Alternator/Starter: 24 VDC, negative ground, 80 amp/hr.

Recommended battery to -18°C (0° F):(2) 12 VDC, BCI# 31, Max. Dimensions: 14”lg x 6 3/4” wi x 10” hi, with standard round posts. Min output 1000 CCA. Battery tray (max. dim. at 15”lg x 7”wi). This model has (2) battery trays, (2) hold down straps, (2) sets of battery cables, and (1) battery charger. Installation of (2) 12VDC starting batteries connected in series for 24VDC output is required, with possible higher AMP/HR rating, as described above, if the normal environment temperature averages -13° F (-25°C) or cooler.

CERTIFICATIONS

All engines are EPA emissions certified. All emergency stationary diesel engines are Tier II compliant.

APPLICATION & ENGINEERING DATA FOR MODEL SPVD-6000-60 HZ

COOLING SYSTEM

Type of System	Air to Air, Charged Air Cooler
Coolant Pump	Pre-lubricated, self-sealing
Cooling Fan Type	Pusher
Fan Diameter inches (cm).....	38 (97)
Fan drive ratio.....	1.04:1
Ambient Capacity of Radiator °F (°C).....	131 (55)
Engine Jacket Coolant Capacity gal. (L).....	8.70 (33)
Radiator Coolant Capacity gal. (L).....	25.1 (95)
Water Pump Capacity gpm (L/min).....	122 (462)
Heat Reject Coolant: Btu/min.....	15,355
Air to Air Heat Reject, BTU/min.	7,677
Heat Radiated to Ambient, BTU/min	3,928
Low Radiator Coolant Level Shutdown.....	Standard
Note: Coolant temp. shut-down switch setting at 228°F (109°C) with 50/50 (water/antifreeze) mix.	

COOLING AIR REQUIREMENTS

Combustion Air cfm (m ³ /min)	1,937 (54.8)
Max Air Intake Restrictions:	
Clean Air Cleaner, KPA (psi).....	5 (1.5)
Radiator Cooling Air, SCFM (m ³ /min).....	31,802 (900)

EXHAUST SYSTEM

Exhaust Outlet Size.....	8"
Max. Back Pressure in KPA (in. H ₂ O).....	10 (40)
Exhaust Flow, at rated KW, CFM (m ³ /min).....	4,153 (118)
Exhaust Temp, (Stack) °F (°C)	954 (512)

SOUND LEVELS MEASURED IN dB(A)

	Open Set	Level 2 Encl.
Level 2, Critical Silencer	98	83
Level 3, Hospital Silencer.....	93	78

Note: Open sets (no enclosure) have optional silencer system choices due to unknown job-site applications. Level 2 enclosure has installed critical silencer with upgrade to Level 3 hospital silencer. Sound tests are averaged from several test points and taken at 23 ft. (7 m) from source of noise at normal operation.

DERATE GENERATOR FOR ALTITUDE

3% per 1000 ft.(305m) above 3000 ft. (914m) from sea level

DERATE GENERATOR FOR TEMPERATURE

2% per 10°F(5.6°C) above 104°F (40°C)

DIMENSIONS AND WEIGHTS

	Open Set	Level 2 Enclosure
Length in (cm).....	152 (368)	186 (473)
Width in (cm).....	72 (183)	72 (183)
Height in (cm).....	80 (203)	94 (239)
3 Ø Net Weight lbs (kg).....	9825 (4457)	12325 (5591)
3 Ø Ship Weight lbs (kg)	10225 (4638)	12725 (5772)

BASLER DGC-2020 DIGITAL MICROPROCESSOR CONTROLLER



Basler DGC-2020

The “2020” controller is a highly advanced integrated gen-set control system for single gen-set applications. This controller includes a backlit LCD display which continuously displays the status of the engine and generator at all times.

Basler “DGC-2020” includes: Generator metering (including three phase) • Engine – Generator protections including IEEE-[27] under voltage, [32] power, [40] loss of excitation, [59] over voltage, [81] over and under frequency, Exercise timer • SAE J1939 engine ECU communications • Expansion capabilities for both inputs and outputs with expansion • Remote communications through RS-485 to Basler’s RDP110 remote Display panel • (16) programmable contact inputs • (15) programmable contact outputs- (3) for up to 30AmpDC and (12) for up to 2 Amp DC • Illuminated Text Display • Front panel menu scroll buttons • Front panel operation mode buttons for STOP, RUN and AUTO • Alarm Silence and Lamp Test buttons

This controller includes expansion features including, RS485 (using MODBUS), direct USB connection with PC, expansion optioned using BESTCOMSPlus for remote annunciation and remote relay interfacing for a distance of up to 3300FT. The controller software is freely downloadable from the internet and allows monitoring with direct USB cable, LAN, or by internet via the built in web interface.



Further expansion is available by adding the optional RDP-110 remote display panel module. This featured device will allow Four programmable LEDs (2) alarms and (2) pre-alarms • (17) alarms and pre-alarms displayed from Basler controller • audible alarm horn • lamp test and alarm silence buttons • RD100 local power supply inputs of either 12vdc or 24vdc • connects through Basler controller through RS-485 communications protocol • conduit box included for (2) mounting configurations- either surface mount or semi-flush mounting.

STANDARD FEATURES FOR MODEL SPVD-6000-60 HZ

STANDARD FEATURES

CONTROL PANEL:

- Basler DGC-2020 digital microprocessor with logic allows programming in the field. Controller has:
- STOP-MANUAL-AUTO modes and automatic engine shutdowns, signaled by full text LCD indicators:
 - Low oil pressure
 - High engine temp
 - Low Radiator Level
 - Three auxiliary alarms
 - Battery fail alarm
 - Engine fail to start
 - Engine over speed
 - Engine under speed
 - Over & under voltage

Also included is tamper-proof engine hour meter

ENGINE:

- Fuel filter
- Full flow Oil filter
- Air filter
- Fuel pump
- Oil pump
- Solenoid type starter motor
- Hi-temp radiator
- Jacket water pump
- Thermostat
- Pusher fan and guard
- Exhaust manifold
- Electronic Governor
- 24 VDC battery charging alternator
- Flexible fuel and exhaust connectors
- Vibration isolators
- Open coolant recovery system with 50/50 water to anti-freeze mixture
- flexible oil & radiator hose
- Shut-down sensors for low oil pressure, high coolant temp., low coolant level, high ambient temp.

AC GENERATOR SYSTEM:

- AC generator
- Shunt excited
- Brushless design
- Circuit Breaker installed and wired to gen-set
- Direct connection to engine with flex disc
- Class H, 180°C insulation
- Self ventilated
- Drip proof construction
- UL Certified

VOLTAGE REGULATOR:

- 1% Voltage regulation
- EMI filter
- Under-speed protection
- Over-excitation protection
- total encapsulation

DC ELECTRICAL SYSTEM:

- Battery trays
- Battery cables
- Battery hold down straps
- 3-stage battery charger with float, absorption, & bulk automatic charge stages

WEATHER / SOUNDPROOF ALUMINUM HOUSING:

Corrosion Resistant Protection consisting of:

- (9) Heated and Agitated Wash Stages
- Zinc Phosphate Etching-Coating Stage
- Final Baked on Enamel Powder Coat
- 18/8 Stainless Steel Hardware

Design & specifications subject to change without prior notice. Dimensions shown are approximate. Contact Gillette for certified drawings. DO NOT USE DIMENSIONS FOR INSTALLATION PURPOSES.

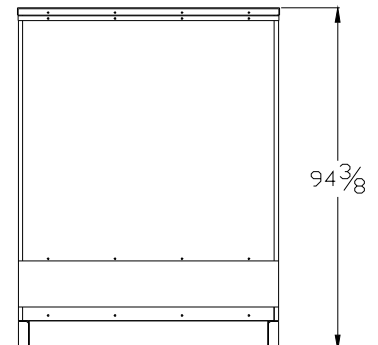
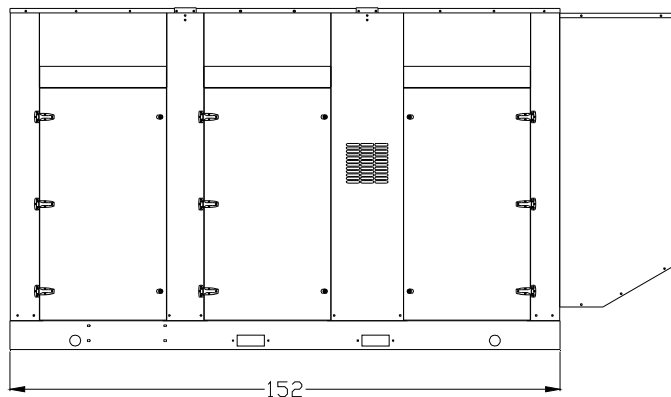
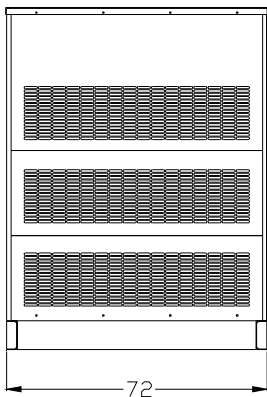
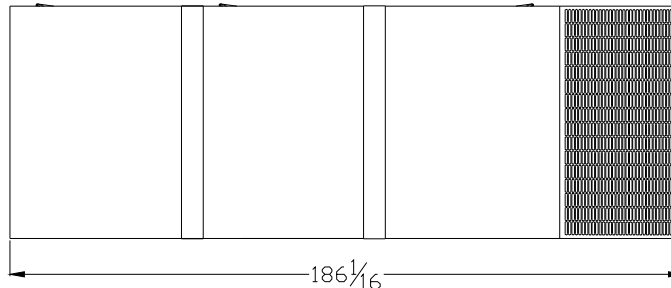

VOLVO PENTA GENSET ENGINE

TWD1643GE

613 kW (834 hp) at 1500 rpm, 674 kW (917 hp) at 1800 rpm, acc. to ISO 3046

The TWD1643GE is a powerful, reliable and economical Generating Set Diesel Engine built on the dependable in-line six design.

Durability & low noise

Designed for easiest, fastest and most economical installation. Well-balanced to produce smooth and vibration-free operation with low noise level.

To maintain a controlled working temperature in cylinders and combustion chambers, the engine is equipped with piston cooling. The engine is also fitted with replaceable cylinder liners and valve seats/guides to ensure maximum durability and service life of the engine.

Low exhaust emission

The state of the art, high-tech injection and charging system with low internal losses contributes to excellent combustion and low fuel consumption.

The TWD1643GE is certified for EPA Tier 2. An additional feature is that TWD1643GE fulfils EU Stage 2 exhaust emission levels.

Easy service & maintenance

Easily accessible service and maintenance points contribute to the ease of service of the engine.

Technical description

Engine and block

- Optimized cast iron cylinder block with optimum distribution of forces without the block being unnecessarily heavy.
- Wet, replaceable cylinder liners
- Piston cooling for low piston temperature and reduced ring temperature
- Tapered connecting rods for reduce risk of piston cracking
- Crankshaft induction hardened bearing surfaces and fillets with seven bearings for moderate load on main and high-end bearings
- Case hardened and Nitrocarburized transmission gears for heavy duty operation
- Keystone top compression rings for long service life
- Viscous type crankshaft vibration dampers to withstand single bearing alternator torsional vibrations
- Replaceable valve guides and valve seats
- Over head camshaft and four valves per cylinder

Lubrication system

- Full flow oil cooler
- Full flow disposable spin-on oil filter, for extra high filtration
- The lubricating oil level can be measured during operation

- Gear type lubricating oil pump, gear driven by the transmission

Fuel system

- Non-return fuel valve
- Electronic unit injectors
- Fuel prefilter with water separator and water-in-fuel indicator / alarm
- Gear driven low-pressure fuel pump
- Fine fuel filter with manual feed pump and fuel pressure switch
- Fuel shut-off valve

Cooling system

- TWD-cooling system with optimized priority and cold start valves
- Two water cooled charge air coolers
- Efficient cooling with accurate coolant control through a water distribution duct in the cylinder block. Reliable sleeve thermostat with minimum pressure drop
- Belt driven, maintenance-free coolant pump with high degree of efficiency

Turbo charger

- Efficient and reliable dual stage turbo chargers

- Intermediate charge air coolers for both turbo chargers
- Waste gate system for the high pressure turbo charger

Electrical system

- Engine Management System 2 (EMS 2), an electronically controlled processing system which optimizes engine performance. It also includes advanced facilities for diagnostics and fault tracing
- The instruments and controls connect to the engine via the CAN SAE J1939 interface, either through the Control Interface Unit (CIU) or the Display Control Unit (DCU). The CIU converts the digital CAN bus signal to an analog signal, making it possible to connect a variety of instruments. The DCU is a control panel with display, engine control, monitoring, alarm, parameter setting and diagnostic functions. The DCU also presents error codes in clear text.
- Sensors for oil pressure, oil temp, boost pressure, boost temp, exhaust temp, coolant temp, fuel temp, water in fuel, fuel pressure and two speed sensors.



Features

- Fully electronic with Volvo Penta EMS 2
- Dual frequency switch (between 1500 rpm and 1800 rpm)
- High power density
- Emission compliant
- Low noise levels
- Low fuel consumption
- Gen Pac configuration
- Compact design for the power class

**VOLVO
PENTA**

TWD1643GE

Technical Data

General

Engine designation	TWD1643GE	
No. of cylinders and configuration.....	in-line 6	
Method of operation	4-stroke	
Bore, mm (in.).....	144 (5.67)	
Stroke, mm (in.).....	165 (6.50)	
Displacement, l (in ³).....	16.12 (983.7)	
Compression ratio.....	16.5:1	
Dry weight, kg (lb).....	1700 (3748)	
Dry weight with Gen Pac, kg (lb).....	2200 (4850)	
Wet weight, kg (lb).....	1770 (3902)	
Wet weight with Gen Pac, kg (lb).....	2370 (5225)	

Performance	1500 rpm	1800 rpm
with fan, kW (hp) at:		
Prime Power	536 (729)	585 (796)
Max Standby Power	596 (811)	644 (876)

Lubrication system	1500 rpm	1800 rpm
Oil consumption, liter/h (US gal/h) at:		
Prime Power	0.10 (0.026)	0.10 (0.026)
Max Standby Power	0.11 (0.029)	0.11 (0.039)
Oil system capacity incl filters, liter	48	

Fuel system	1500 rpm	1800 rpm
Specific fuel consumption at:		
Prime Power, g/kWh (lb/hph)		
25 %	215 (0.349)	224 (0.363)
50 %	196 (0.318)	201 (0.326)
75 %	196 (0.318)	197 (0.319)
100 %	199 (0.323)	202 (0.327)
Max Standby Power, g/kWh (lb/hph)		
25 %	210 (0.340)	220 (0.357)
50 %	195 (0.316)	200 (0.324)
75 %	196 (0.318)	198 (0.321)
100 %	200 (0.324)	204 (0.331)

Intake and exhaust system	1500 rpm	1800 rpm
Air consumption, m ³ /min (cfm) at:		
Prime Power	44 (1541)	53 (1874)
Max Standby Power	47 (1658)	55 (1937)
Max allowable air intake restriction, kPa (PSI)	5 (0.7)	5 (0.7)
Heat rejection to exhaust, kW (BTU/min) at:		
Prime Power	415 (23601)	472 (26842)
Max Standby Power	463 (26330)	530 (30141)
Exhaust gas temperature after low pressure turbine, °C (°F) at:		
Prime Power	450 (842)	422 (792)
Max Standby Power	463 (865)	461 (862)
Max allowable back-pressure in exhaust line, kPa (PSI)	10 (1.5)	10 (1.5)
Exhaust gas flow, m ³ /min (cfm) at:		
Prime power	101.6 (3586)	119 (4201)
Max Standby Power	111.8 (3949)	130.1 (4593)

Standard equipment

	Engine	Gen Pac
Engine		
Automatic belt tensioner	•	•
Lift eyelets	•	•
Flywheel		
Flywheel housing with conn. acc. to SAE 1	•	•
Flywheel for 14" flex. plate and flexible coupling	•	•
Vibration dampers	•	•
Engine suspension		
Fixed front suspension	•	•
Lubrication system		
Oil dipstick	•	•
Full-flow oil filter of spin-on type	•	•
By-pass oil filter of spin-on type	•	•
Oil cooler, side mounted	•	•
Low noise oil sump	•	•
Fuel system		
Fuel filters of spin-on type	•	•
Electronic unit injectors	•	•
Pre-filter with water separator	•	•
Intake and exhaust system		
Air filter without rain cover	•	•
Air restriction indicator	•	•
Air cooled exhaust manifold	•	•
Connecting flange for exhaust pipe	•	•
Exhaust flange with v-clamp	•	•
Turbo chargers, dual stage, right side	•	•
Cooling system		
TWD-cooling system	•	•
Belt driven driven coolant pump	•	•
Fan hub	•	•
Pusher fan	-	•
Fan guard	-	•
Belt guard	-	•
Control system		
Engine Management System (EMS) with CAN-bus interface SAE J1939	•	•
CIU, Control Interface Unit	-	-
DCU, Display Control Unit	-	-
Alternator		
Alternator 80A / 24 V	•	•
Starting system		
Starter motor, 7.0kW, 24 V	•	•
Instruments and senders		
Temp. and pressure for automatic stop/alarm	•	•
Other equipment		
Expandable base frame	-	•
Engine Packing		
Plastic wrapping	•	•

- optional equipment or not applicable
• included in standard specification

Dimensions TWD1643GE

Not for installation

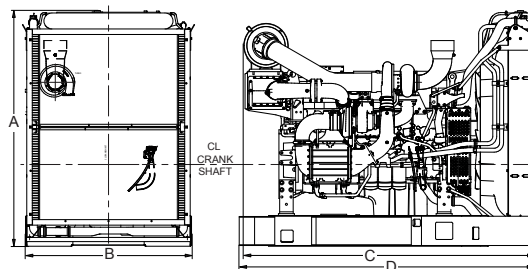

A* = 1925 mm / 76 in
B* = 1350 mm / 53.1 in (max width 1401 mm / 55.2 in)
C = 2362 mm / 93 in
D = 2399 mm / 94.5 in (During transport)
D = Max 3255 mm / 128.2 in
* Including radiator and intercooler

Note! Not all models, standard equipment and accessories are available in all countries. All specifications are subject to change without notice. The engine illustrated may not be entirely identical to production standard engines.

Power Standards

The engine performance corresponds to ISO 3046, BS 5514 and DIN 6271. The technical data applies to an engine without cooling fan and operating on a fuel with calorific value of 42.7 MJ/kg (18360 BTU/lb) and a density of 0.84 kg/liter (7.01 lb/US gal), also where this involves a deviation from the standards. Power output guaranteed within 0 to +2% at rated ambient conditions at delivery. Ratings are based on ISO 8528.

Engine speed governing in accordance with ISO 3046/IV, class A1 and ISO 8528-5 class G3

Exhaust emissions

The TWD1643GE is certified for EPA Tier 2. An additional feature is that TWD1643GE fulfills EU Stage 2 exhaust emission levels.

Rating Guidelines

PRIME POWER rating corresponds to ISO Standard Power for continuous operation. It is applicable for supplying electrical power at variable load for an unlimited number of hours instead of commercially purchased power. A10 % overload capability for governing purpose is available for this rating. MAXIMUM STANDBY POWER rating corresponds to ISO Standard Fuel Stop Power. It is applicable for supplying standby electrical power at variable load in areas with well established electrical networks in the event of normal utility power failure. No overload capability is available for this rating.
1 hp = 1 kW x 1.36

Information

For more technical data and information, please look in the Generator Set Engines Sales Guide.

VOLVO PENTA

AB Volvo Penta
SE-405 08 Göteborg, Sweden
www.volvopenta.com

STAMFORD®

HCI634G - Winding 311 and 312

Technical  Data Sheet

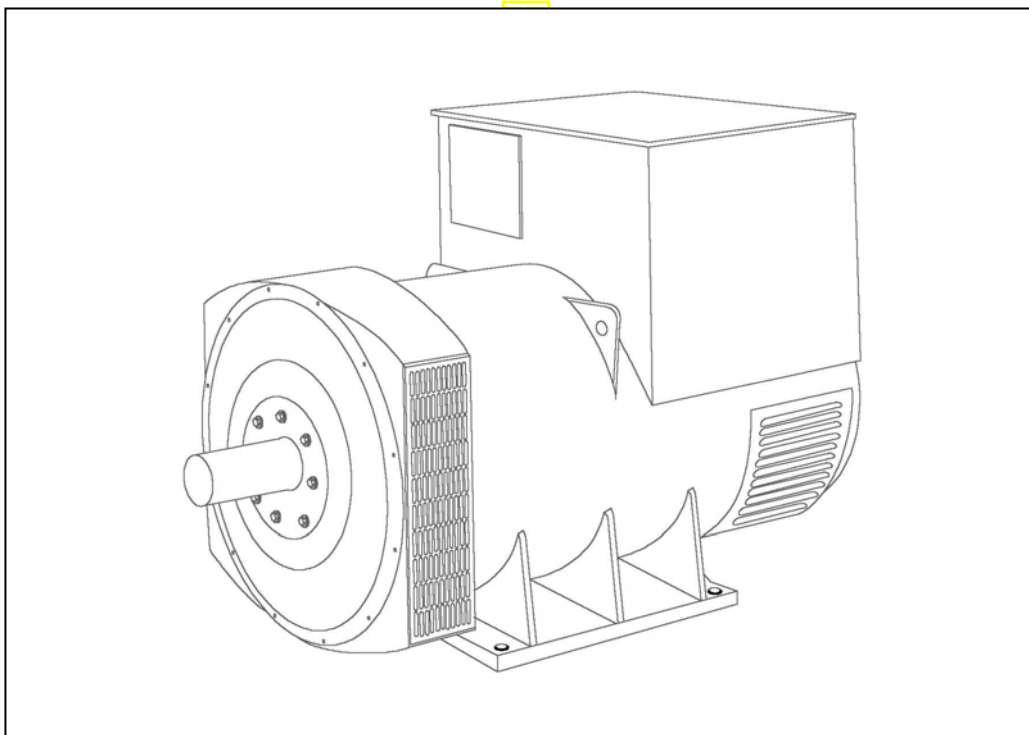

HCI634G

SPECIFICATIONS & OPTIONS

WINDING 311 and 312

STAMFORD

STANDARDS

Stamford industrial generators meet the requirements of BS EN 60034 and the relevant section of other international standards such as BS5000, VDE 0530, NEMA MG1-32, IEC34, CSA C22.2-100, AS1359. Other standards and certifications can be considered on request.

VOLTAGE REGULATORS

MX321 AVR - STANDARD

This sophisticated Automatic Voltage Regulator (AVR) is incorporated into the Stamford Permanent Magnet Generator (PMG) system and is fitted as standard to generators of this type.

The PMG provides power via the AVR to the main exciter, giving a source of constant excitation power independent of generator output. The main exciter output is then fed to the main rotor, through a full wave bridge, protected by a surge suppressor. The AVR has in-built protection against sustained over-excitation, caused by internal or external faults. This de-excites the machine after a minimum of 5 seconds.

Over voltage protection is built-in and short circuit current level adjustments is an optional facility.

WINDINGS & ELECTRICAL PERFORMANCE

All generator stators are wound to 2/3 pitch. This eliminates triplen (3rd, 9th, 15th ...) harmonics on the voltage waveform and is found to be the optimum design for trouble-free supply of non-linear loads. The 2/3 pitch design avoids excessive neutral currents sometimes seen with higher winding pitches, when in parallel with the mains. A fully connected damper winding reduces oscillations during paralleling. This winding, with the 2/3 pitch and carefully selected pole and tooth designs, ensures very low waveform distortion.

TERMINALS & TERMINAL BOX

Standard generators feature a main stator with either 6 ends (Winding 312) or 12 ends (Winding 311) brought out to the terminals, which are mounted on the frame at the non-drive end of the generator. A sheet steel terminal box contains the AVR and provides ample space for the customers' wiring and gland arrangements. It has removable panels for easy access.

SHAFT & KEYS

All generator rotors are dynamically balanced to better than BS6861:Part 1 Grade 2.5 for minimum vibration in operation. Two bearing generators are balanced with a half key.

INSULATION/IMPREGNATION

The insulation system is class 'H'.

All wound components are impregnated with materials and processes designed specifically to provide the high build required for static windings and the high mechanical strength required for rotating components.

QUALITY ASSURANCE

Generators are manufactured using production procedures having a quality assurance level to BS EN ISO 9001.

The stated voltage regulation may not be maintained in the presence of certain radio transmitted signals. Any change in performance will fall within the limits of Criteria 'B' of EN 61000-6-2:2001. At no time will the steady-state voltage regulation exceed 2%.

DE RATES

All values tabulated on page 8 are subject to the following reductions

5% when air inlet filters are fitted.

10% when IP44 Filters are fitted.

3% for every 500 metres by which the operating altitude exceeds 1000 metres above mean sea level.

3% for every 5°C by which the operational ambient temperature exceeds 40°C.

Note: Requirement for operating in an ambient exceeding 60°C must be referred to the factory.

NB Continuous development of our products entitles us to change specification details without notice, therefore they must not be regarded as binding.

Front cover drawing typical of product range.

APPROVED DOCUMENT

WINDING 311 and 312

CONTROL SYSTEM	SEPARATELY EXCITED BY P.M.G.		
A.V.R.	MX321		
VOLTAGE REGULATION	± 0.5 %	With 4% ENGINE GOVERNING	
SUSTAINED SHORT CIRCUIT	REFER TO SHORT CIRCUIT DECREMENT CURVES (page 7)		

INSULATION SYSTEM	CLASS H		
PROTECTION	IP23		
RATED POWER FACTOR	0.8		
STATOR WINDING	DOUBLE LAYER LAP		
WINDING PITCH	TWO THIRDS		
WINDING LEADS	6 (Wdg 312) or 12 (Wdg 311)		
STATOR WDG. RESISTANCE	0.003 Ohms PER PHASE AT 22°C STAR CONNECTED		
ROTOR WDG. RESISTANCE	1.75 Ohms at 22°C		
EXCITER STATOR RESISTANCE	17 Ohms at 22°C		
EXCITER ROTOR RESISTANCE	0.079 Ohms PER PHASE AT 22°C		
R.F.I. SUPPRESSION	BS EN 61000-6-2 & BS EN 61000-6-4, VDE 0875G, VDE 0875N. refer to factory for others		
WAVEFORM DISTORTION	NO LOAD < 1.5% NON-DISTORTING BALANCED LINEAR LOAD < 5.0%		
MAXIMUM OVERSPEED	2250 Rev/Min		
BEARING DRIVE END	BALL. 6224 (ISO)		
BEARING NON-DRIVE END	BALL. 6317 (ISO)		

	1 BEARING				2 BEARING			
WEIGHT COMP. GENERATOR	1965 kg				1989 kg			
WEIGHT WOUND STATOR	934 kg				934 kg			
WEIGHT WOUND ROTOR	814 kg				766 kg			
WR ² INERTIA	18.3482 kgm ²				17.8009 kgm ²			
SHIPPING WEIGHTS in a crate	2023kg				2029kg			
PACKING CRATE SIZE	183 x 92 x 140(cm)				183 x 92 x 140(cm)			
	50 Hz				60 Hz			
TELEPHONE INTERFERENCE	THF<2%				TIF<50			
COOLING AIR	1.614 m ³ /sec 3420 cfm				1.961 m ³ /sec 4156 cfm			
VOLTAGE STAR	380/220	400/231	415/240	440/254	416/240	440/254	460/266	480/277
VOLTAGE PARALLEL STAR (*)	190/110	200/115	208/120	220/127	208/120	220/127	230/133	240/138
VOLTAGE DELTA	220	230	240	254	240	254	266	277
KVA BASE RATING FOR REACTANCE VALUES	800	800	800	800	875	925	963	1000
X _d DIR. AXIS SYNCHRONOUS	3.14	2.83	2.63	2.34	3.53	3.34	3.18	3.03
X' _d DIR. AXIS TRANSIENT	0.25	0.23	0.21	0.19	0.28	0.26	0.25	0.24
X'' _d DIR. AXIS SUBTRANSIENT	0.18	0.16	0.15	0.13	0.21	0.20	0.19	0.18
X _q QUAD. AXIS REACTANCE	1.88	1.70	1.58	1.40	2.10	1.98	1.89	1.80
X' _q QUAD. AXIS SUBTRANSIENT	0.21	0.19	0.18	0.16	0.24	0.23	0.22	0.21
X _L LEAKAGE REACTANCE	0.10	0.09	0.08	0.07	0.12	0.11	0.10	0.10
X ₂ NEGATIVE SEQUENCE	0.22	0.20	0.19	0.17	0.24	0.23	0.22	0.21
X ₀ ZERO SEQUENCE	0.03	0.03	0.03	0.02	0.03	0.03	0.03	0.03

REACTANCES ARE SATURATED

VALUES ARE PER UNIT AT RATING AND VOLTAGE INDICATED

T' _d TRANSIENT TIME CONST.	0.185
T'' _d SUB-TRANSTIME CONST.	0.025
T' _{do} O.C. FIELD TIME CONST.	2.35
T _a ARMATURE TIME CONST.	0.04
SHORT CIRCUIT RATIO	1/X _d

(*) Parallel Star connection only available with Wdg 311

50
Hz

STAMFORD

HCI634G
WINDING 311 and 312

THREE PHASE EFFICIENCY CURVES

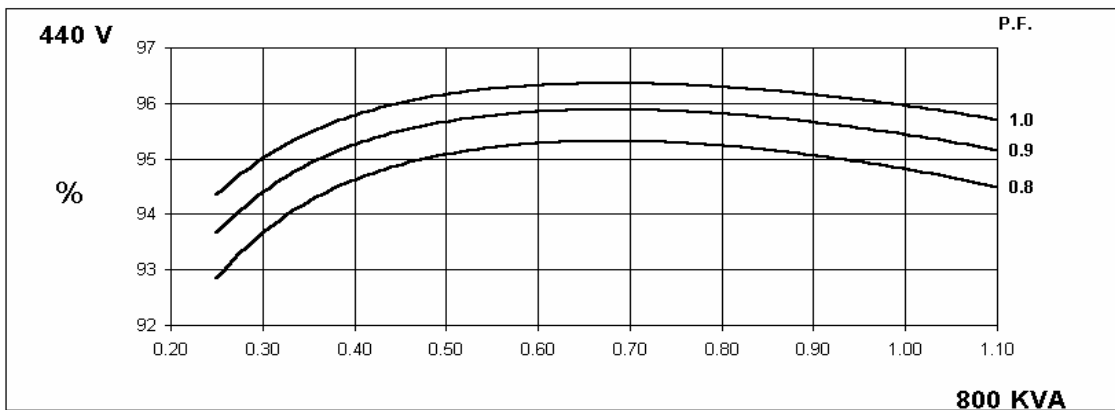
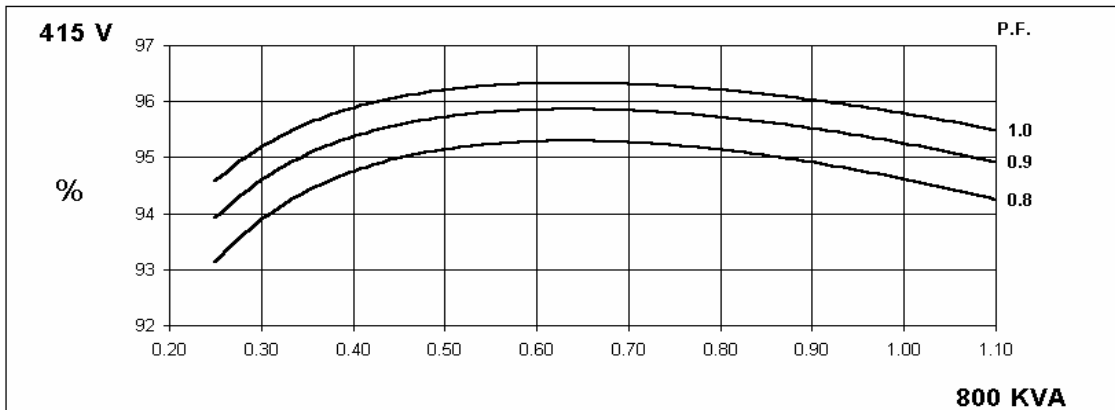
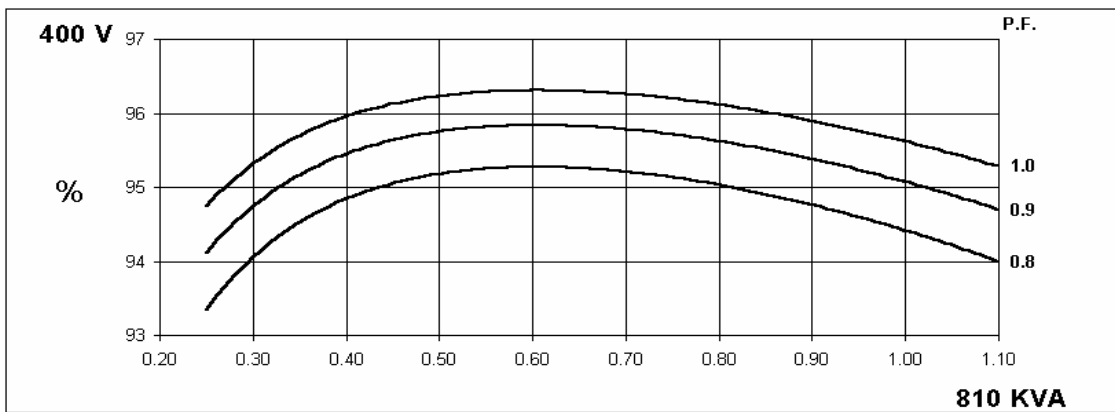
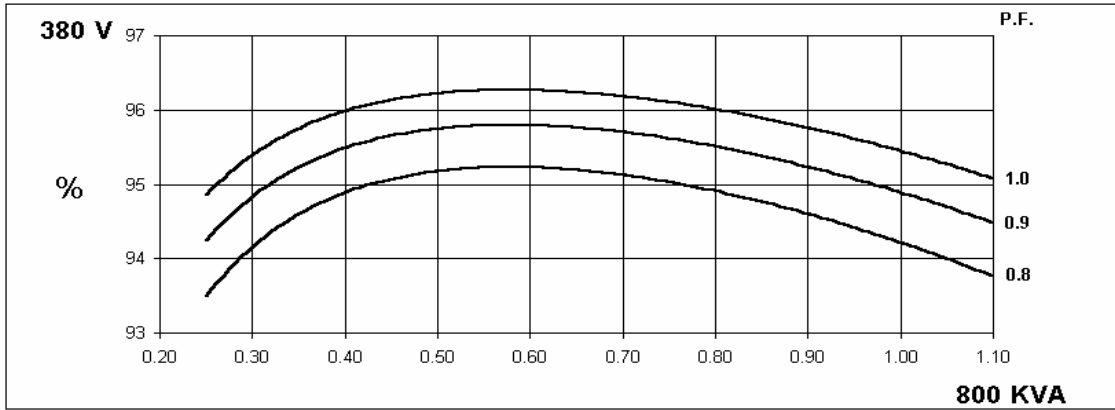

60
Hz

HCI634G
WINDING 311 and 312

STAMFORD

THREE PHASE EFFICIENCY CURVES

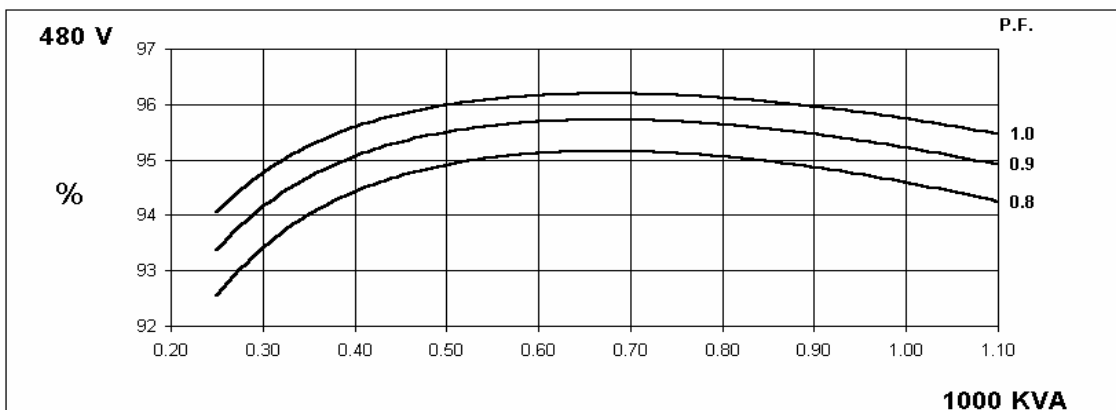
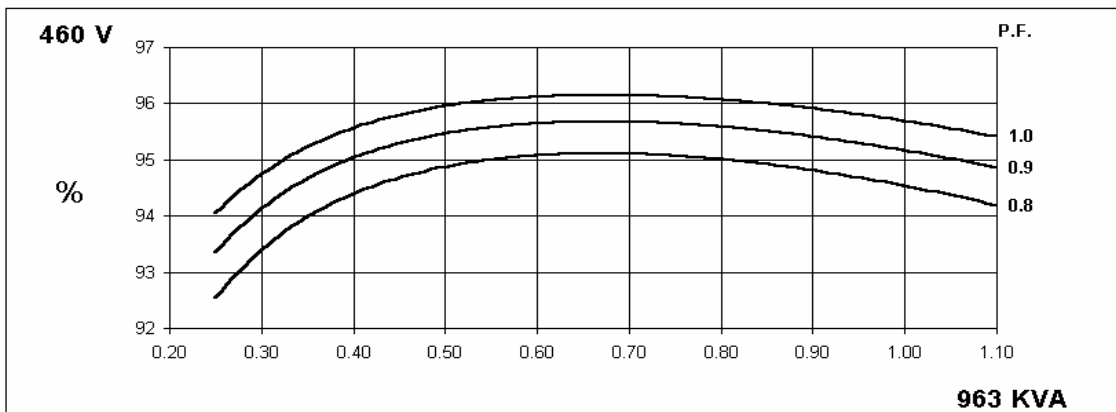
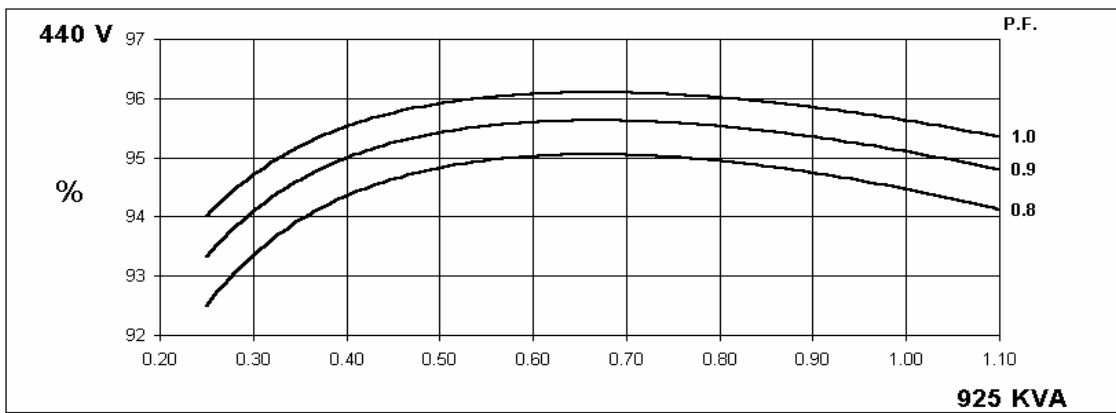
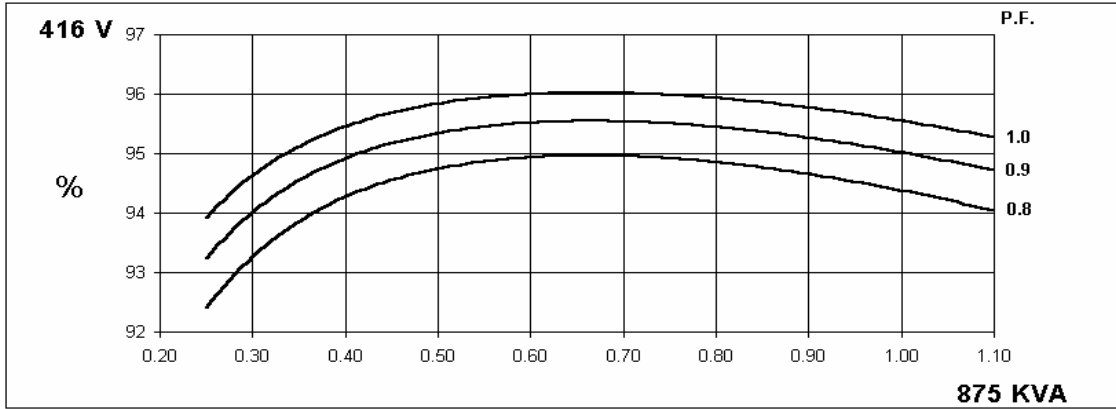

HCI634G
WINDING 311 and 312

STAMFORD

Locked Rotor Motor Starting Curve

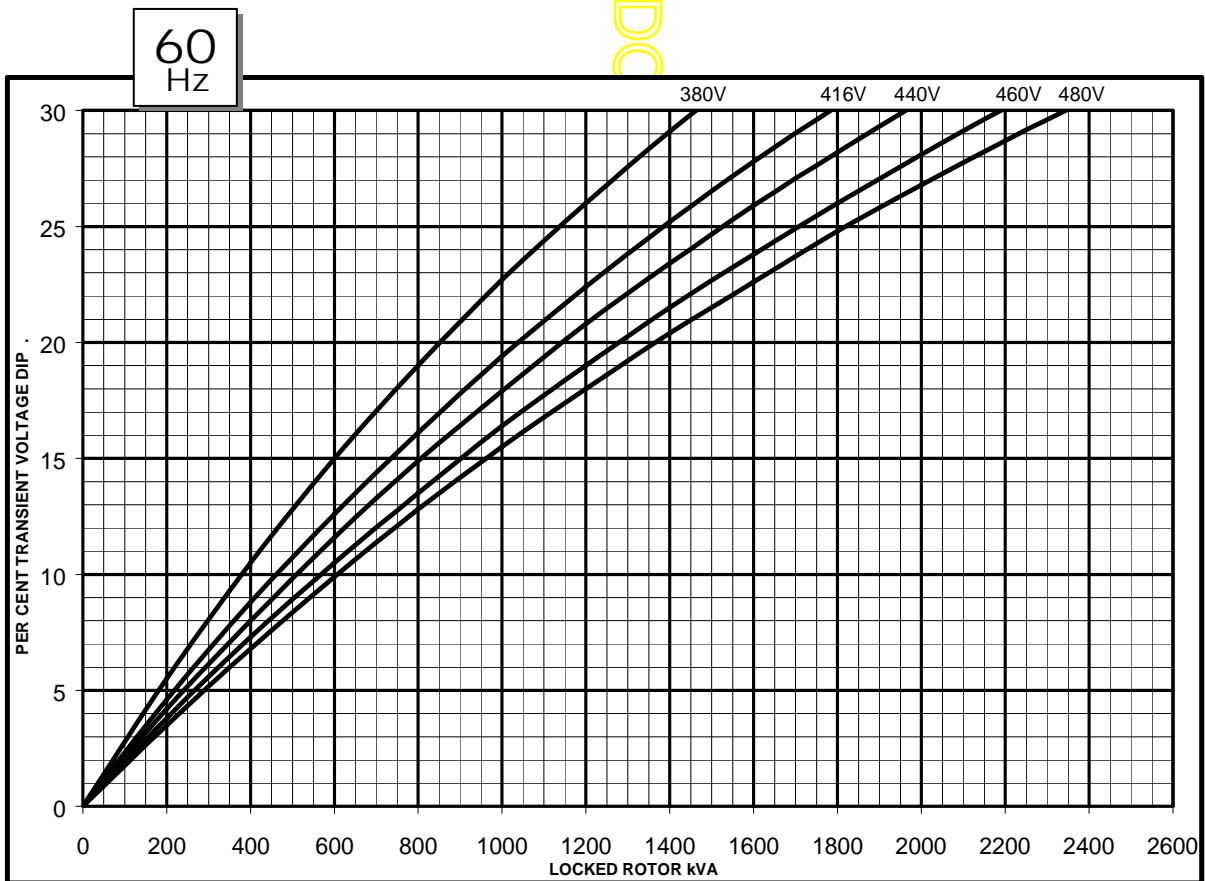
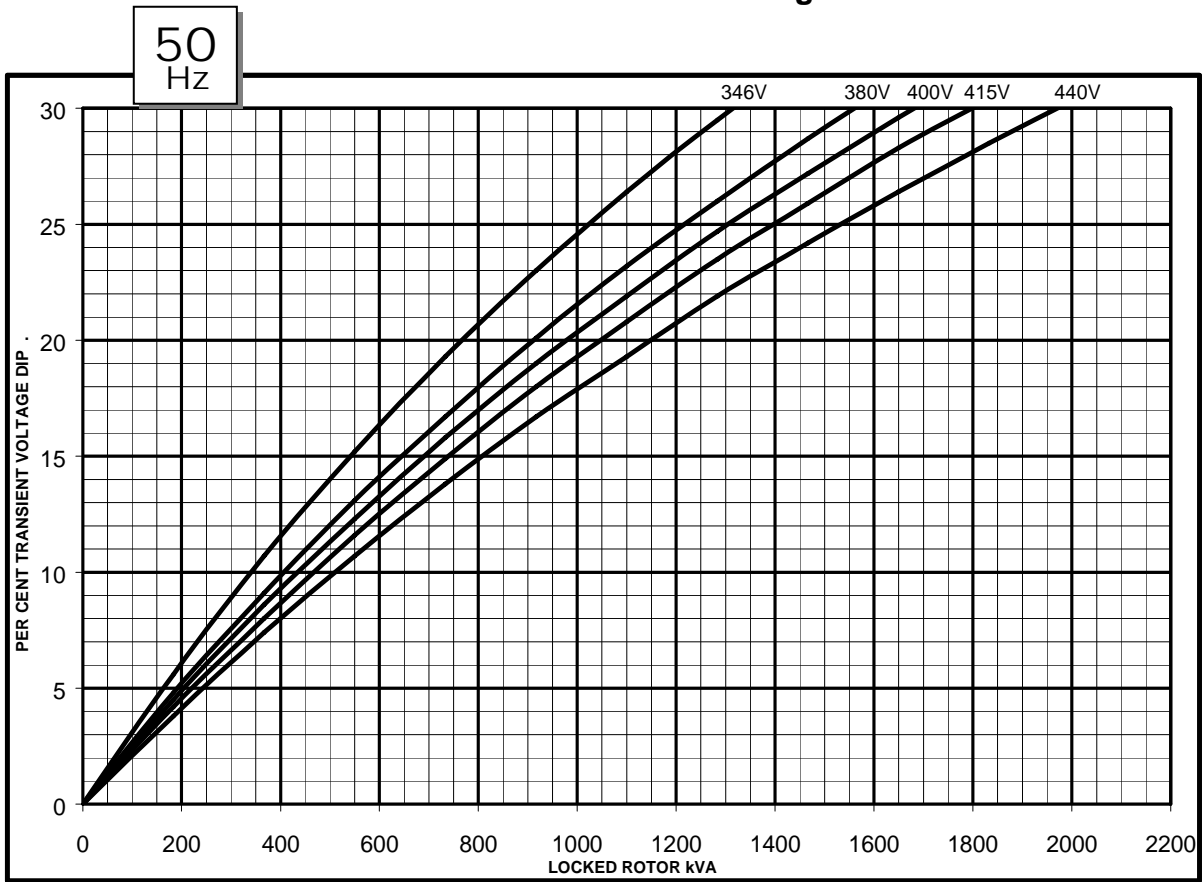

WINDING 311 and 312

**Three-phase Short Circuit Decrement Curve. No-load Excitation at Rated Speed
Based on star (wye) connection.**

50
Hz

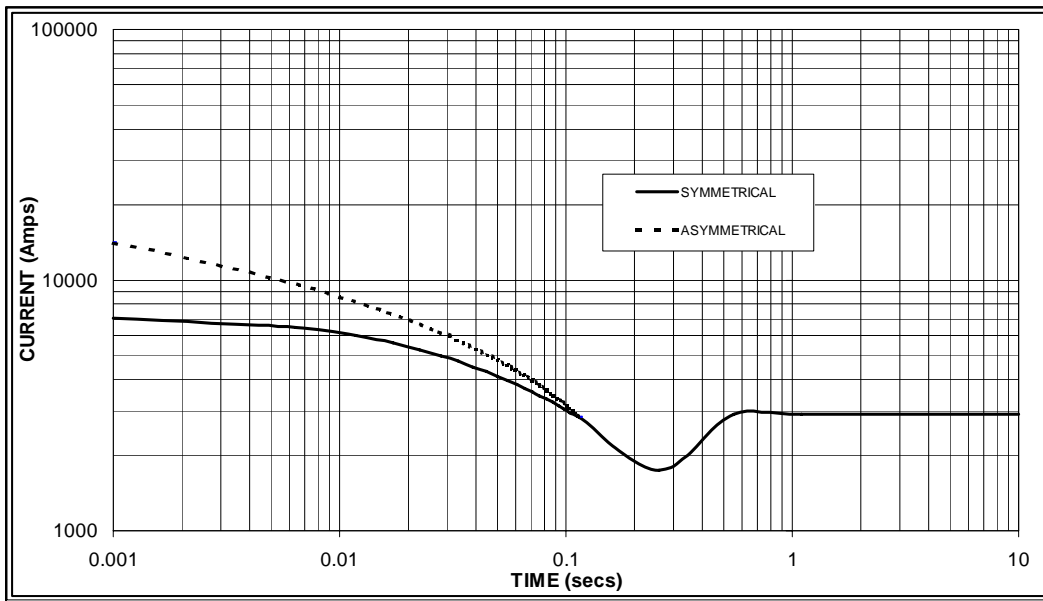

Sustained Short Circuit = 2,900 Amps



60
Hz

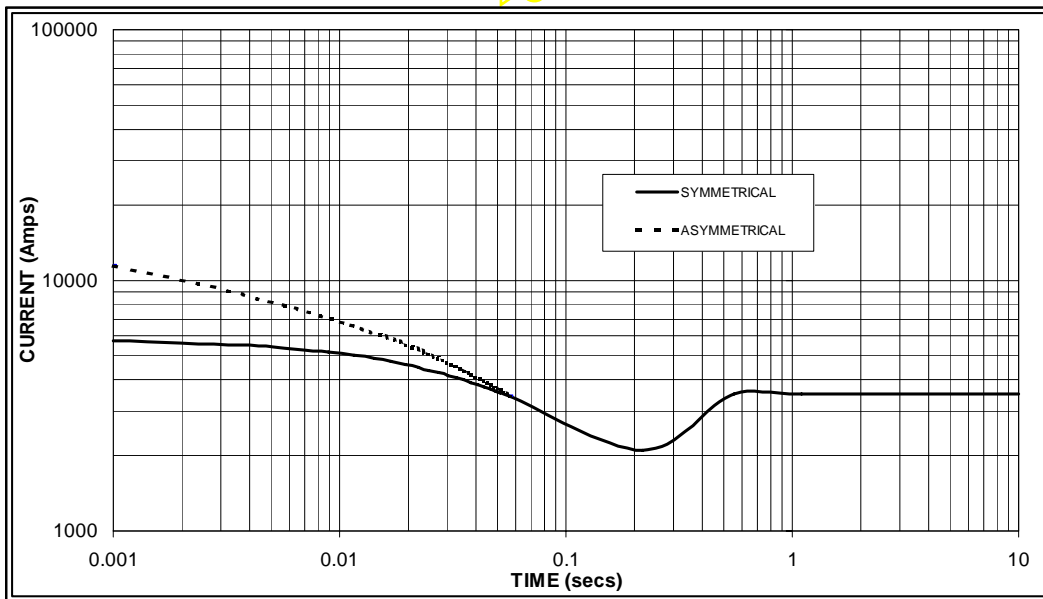

Sustained Short Circuit = 3,500 Amps

Note 1

The following multiplication factors should be used to adjust the values from curve between time 0.001 seconds and the minimum current point in respect of nominal operating voltage :

50Hz		60Hz	
Voltage	Factor	Voltage	Factor
380v	X 1.00	416v	x 1.00
400v	X 1.07	440v	x 1.06
415v	X 1.12	460v	x 1.12
440v	X 1.18	480v	x 1.17

The sustained current value is constant irrespective of voltage level

Note 2

The following multiplication factor should be used to convert the values calculated in accordance with NOTE 1 to those applicable to the various types of short circuit :

	3-phase	2-phase L-L	1-phase L-N
Instantaneous	x 1.00	x 0.87	x 1.30
Minimum	x 1.00	x 1.80	x 3.20
Sustained	x 1.00	x 1.50	x 2.50
Max. sustained duration	10 sec.	5 sec.	2 sec.

All other times are unchanged

Note 3

Curves are drawn for Star (Wye) connected machines. For Delta connection multiply the Curve current value by 1.732

HCI634G

Winding 311 and 312 0.8 Power Factor

RATINGS

Class - Temp Rise	Cont. F - 105/40°C				Cont. H - 125/40°C				Standby - 150/40°C				Standby - 163/27°C				
50Hz	Star (V)	380	400	415	440	380	400	415	440	380	400	415	440	380	400	415	440
	Parallel Star (V) *	180	200	208	220	180	200	208	220	180	200	208	220	180	200	208	220
	Delta (V)	220	230	240	254	220	230	240	254	220	230	240	254	220	230	240	254
	kVA	750	760	750	750	800	810	800	800	825	830	825	820	850	860	850	850
	kW	600	608	600	600	640	648	640	640	660	664	660	656	680	688	680	680
	Efficiency (%)	94.5	94.6	94.8	95.0	94.2	94.4	94.6	94.8	94.1	94.3	94.5	94.7	93.9	94.2	94.4	94.6
	kW Input	635	643	633	632	679	686	677	675	702	704	698	693	724	730	720	719

60Hz	Star (V)	416	440	460	480	416	440	460	480	416	440	460	480	416	440	460	480
	Parallel Star (V) *	208	220	230	240	208	220	230	240	208	220	230	240	208	220	230	240
	Delta (V)	240	254	266	277	240	254	266	277	240	254	266	277	240	254	266	277
	kVA	813	844	888	913	875	925	963	1000	913	969	1008	1046	950	1000	1044	1088
	kW	650	675	710	730	700	740	770	800	730	775	806	837	760	800	835	870
	Efficiency (%)	94.6	94.7	94.8	94.8	94.4	94.5	94.5	94.6	94.2	94.3	94.4	94.4	94.1	94.2	94.3	94.3
	kW Input	688	713	749	770	742	783	815	846	775	822	854	886	808	849	886	923

* Parallel Star only available with Wdg 311

DIMENSIONS

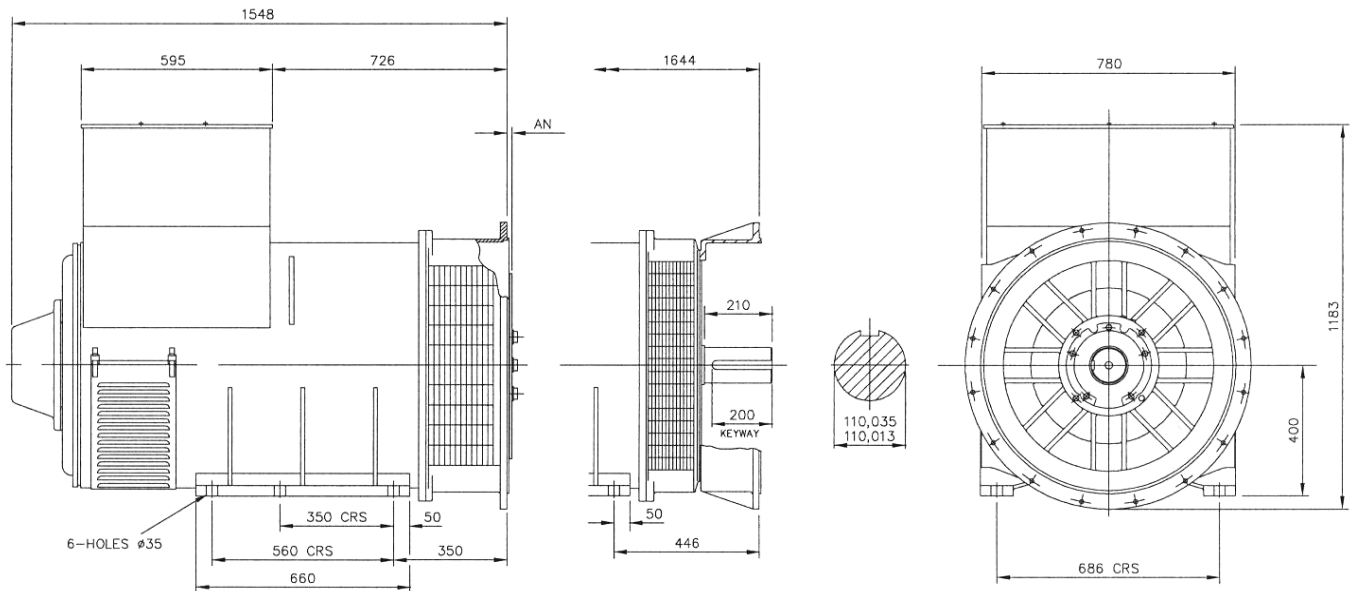

SAE	14	18	21	24
AN	25.4	15.87	0	0

APPROVED DOCUMENT

STAMFORD

Head Office Address:
Barnack Road, Stamford
Lincolnshire, PE9 2NB
United Kingdom
Tel: +44 (0) 1780 484000
Fax: +44 (0) 1780 484100

www.cumminsgeneratortechnologies.com

Copyright 2010, Cummins Generator Technologies Ltd, All Rights Reserved
Stamford and AvK are registered trade marks of Cummins Generator Technologies Ltd
Cummins and the Cummins logo are registered trade marks of Cummins Inc.

STAMFORD®

HCI 534E/544E - Winding 311

Technical  Data Sheet

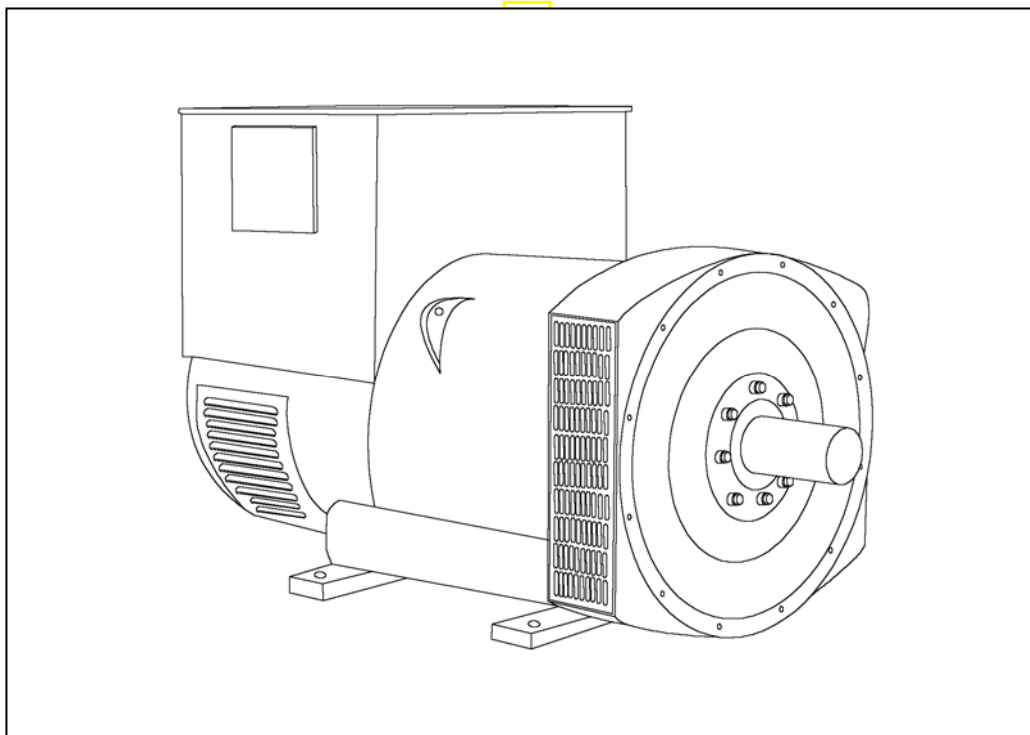

HCI534E/544E

SPECIFICATIONS & OPTIONS

STAMFORD

STANDARDS

Stamford industrial generators meet the requirements of BS EN 60034 and the relevant section of other international standards such as BS5000, VDE 0530, NEMA MG1-32, IEC34, CSA C22.2 100, AS1359.

Other standards and certifications can be considered on request.

VOLTAGE REGULATORS

AS440 AVR - STANDARD

With this self-excited system the main stator provides power via the Automatic Voltage Regulator (AVR) to the exciter stator. The high efficiency semi-conductors of the AVR ensure positive build-up from initial low levels of residual voltage.

The exciter rotor output is fed to the main rotor through a three-phase full-wave bridge rectifier. The rectifier is protected by a surge suppressor against surges caused, for example, by short circuit or out-of-phase paralleling.

The AS440 will support a range of electronic accessories, including a 'droop' Current Transformer (CT) to permit parallel operation with other ac generators.

MX341 AVR

This sophisticated AVR is incorporated into the Stamford Permanent Magnet Generator (PMG) control system.

The PMG provides power via the AVR to the main exciter, giving a source of constant excitation power independent of generator output. The main exciter output is then fed to the main rotor through a full wave bridge, protected by a surge suppressor.

The AVR has in-built protection against sustained over-excitation, caused by internal or external faults. This de-excites the machine after a minimum of 5 seconds.

An engine relief load acceptance feature can enable full load to be applied to the generator in a single step.

If three-phase sensing is required with the PMG system the MX321 AVR must be used.

We recommend three-phase sensing for applications with greatly unbalanced or highly non-linear loads.

MX321 AVR

The most sophisticated of all our AVRs combines all the features of the MX341 with, additionally, three-phase rms sensing, for improved regulation and performance.

Over voltage protection is built-in and short circuit current level adjustments is an optional facility.

WINDINGS & ELECTRICAL PERFORMANCE

All generator stators are wound to 2/3 pitch. This eliminates triplen (3rd, 9th, 15th ...) harmonics on the voltage waveform and is found to be the optimum design for trouble-free supply of non-linear loads. The 2/3 pitch design avoids excessive neutral currents sometimes seen with higher winding pitches, when in parallel with the mains. A fully connected damper winding reduces oscillations during paralleling. This winding, with the 2/3 pitch and carefully selected pole and tooth designs, ensures very low waveform distortion.

TERMINALS & TERMINAL BOX

Standard generators are 3-phase reconnectable with 12 ends brought out to the terminals, which are mounted on a cover at the non-drive end of the generator. A sheet steel terminal box contains the AVR and provides ample space for the customers' wiring and gland arrangements. It has removable panels for easy access.

SHAFT & KEYS

All generator rotors are dynamically balanced to better than BS6861:Part 1 Grade 2.5 for minimum vibration in operation. Two bearing generators are balanced with a half key.

INSULATION/IMPREGNATION

The insulation system is class 'H'.

All wound components are impregnated with materials and processes designed specifically to provide the high build required for static windings and the high mechanical strength required for rotating components.

QUALITY ASSURANCE

Generators are manufactured using production procedures having a quality assurance level to BS EN ISO 9001.

The stated voltage regulation may not be maintained in the presence of certain radio transmitted signals. Any change in performance will fall within the limits of Criteria 'B' of EN 61000-6-2:2001. At no time will the steady-state voltage regulation exceed 2%.

DE RATES

All values tabulated on page 8 are subject to the following reductions

5% when air inlet filters are fitted.

3% for every 500 metres by which the operating altitude exceeds 1000 metres above mean sea level.

3% for every 5°C by which the operational ambient temperature exceeds 40°C.

Note: Requirement for operating in an ambient exceeding 60°C must be referred to the factory.

NB Continuous development of our products entitles us to change specification details without notice, therefore they must not be regarded as binding.

Front cover drawing typical of product range.

HCI534E/544E



WINDING 311

CONTROL SYSTEM	SEPARATELY EXCITED BY P.M.G.							
A.V.R.	MX321	MX341						
VOLTAGE REGULATION	± 0.5 %	± 1.0 %	With 4% ENGINE GOVERNING					
SUSTAINED SHORT CIRCUIT	REFER TO SHORT CIRCUIT DECREMENT CURVES (page 7)							
CONTROL SYSTEM	SELF EXCITED							
A.V.R.	AS440							
VOLTAGE REGULATION	± 1.0 %	With 4% ENGINE GOVERNING						
SUSTAINED SHORT CIRCUIT	SERIES 4 CONTROL DOES NOT SUSTAIN A SHORT CIRCUIT CURRENT							
INSULATION SYSTEM	CLASS H							
PROTECTION	IP23							
RATED POWER FACTOR	0.8							
STATOR WINDING	DOUBLE LAYER LAP							
WINDING PITCH	TWO THIRDS							
WINDING LEADS	12							
STATOR WDG. RESISTANCE	0.0043 Ohms PER PHASE AT 22°C SERIES STAR CONNECTED							
ROTOR WDG. RESISTANCE	1.96 Ohms at 22°C							
EXCITER STATOR RESISTANCE	17 Ohms at 22°C							
EXCITER ROTOR RESISTANCE	0.092 Ohms PER PHASE AT 22°C							
R.F.I. SUPPRESSION	BS EN 61000-6-2 & BS EN 61000-6-4, VDE 0875G, VDE 0875N. refer to factory for others							
WAVEFORM DISTORTION	NO LOAD < 1.5% NON-DISTORTING BALANCED LINEAR LOAD < 5.0%							
MAXIMUM OVERSPEED	2250 Rev/Min							
BEARING DRIVE END	BALL. 6220 (ISO)							
BEARING NON-DRIVE END	BALL. 6314 (ISO)							
	1 BEARING				2 BEARING			
WEIGHT COMP. GENERATOR	1543 kg				1535 kg			
WEIGHT WOUND STATOR	722 kg				722 kg			
WEIGHT WOUND ROTOR	617 kg				588 kg			
WR ² INERTIA	8.9828 kgm ²				8.7049 kgm ²			
SHIPPING WEIGHTS in a crate	1635 kg				1625 kg			
PACKING CRATE SIZE	166 x 87 x 124(cm)				166 x 87 x 124(cm)			
	50 Hz				60 Hz			
TELEPHONE INTERFERENCE	THF<2%				TIF<50			
COOLING AIR	1.035 m ³ /sec 2202 cfm				1.312 m ³ /sec 2780 cfm			
VOLTAGE SERIES STAR	380/220	400/231	415/240	440/254	416/240	440/254	460/266	480/277
VOLTAGE PARALLEL STAR	190/110	200/115	208/120	220/127	208/120	220/127	230/133	240/138
VOLTAGE SERIES DELTA	220/110	230/115	240/120	254/127	240/120	254/127	266/133	277/138
KVA BASE RATING FOR REACTANCE VALUES	600	610	600	600	681	713	731	750
X _d DIR. AXIS SYNCHRONOUS	3.14	2.88	2.63	2.34	3.53	3.30	3.10	2.92
X' _d DIR. AXIS TRANSIENT	0.17	0.15	0.14	0.12	0.17	0.16	0.15	0.14
X'' _d DIR. AXIS SUBTRANSIENT	0.12	0.11	0.10	0.09	0.12	0.11	0.11	0.10
X _q QUAD. AXIS REACTANCE	2.45	2.25	2.05	1.82	2.82	2.64	2.48	2.33
X'' _q QUAD. AXIS SUBTRANSIENT	0.26	0.24	0.22	0.20	0.34	0.32	0.30	0.28
X _L LEAKAGE REACTANCE	0.06	0.05	0.05	0.04	0.06	0.06	0.05	0.05
X ₂ NEGATIVE SEQUENCE	0.18	0.16	0.15	0.13	0.23	0.22	0.20	0.19
X ₀ ZERO SEQUENCE	0.08	0.08	0.07	0.06	0.10	0.09	0.09	0.08
REACTANCES ARE SATURATED				VALUES ARE PER UNIT AT RATING AND VOLTAGE INDICATED				
T' _d TRANSIENT TIME CONST.	0.08s							
T'' _d SUB-TRANSTIME CONST.	0.012s							
T' _{do} O.C. FIELD TIME CONST.	2.5s							
T _a ARMATURE TIME CONST.	0.019s							
SHORT CIRCUIT RATIO	1/X _d							

50
Hz

HCI534E/544E

STAMFORD

Winding 311

THREE PHASE EFFICIENCY CURVES

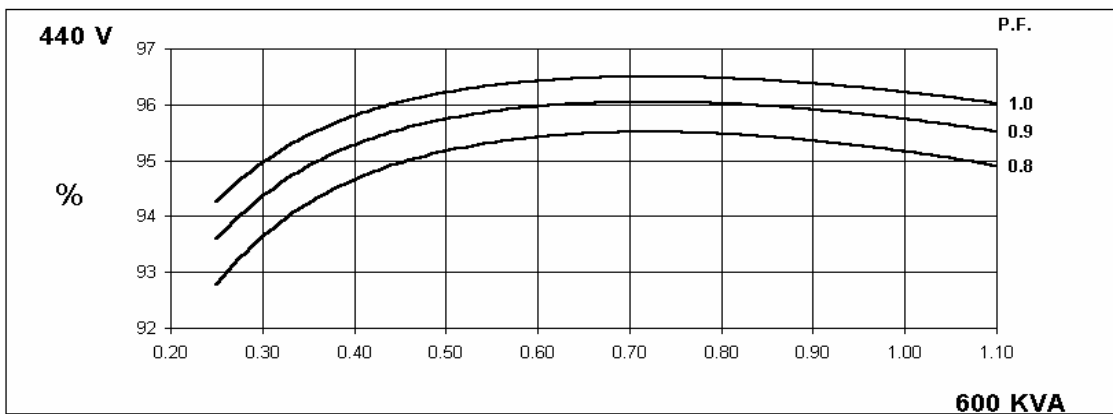
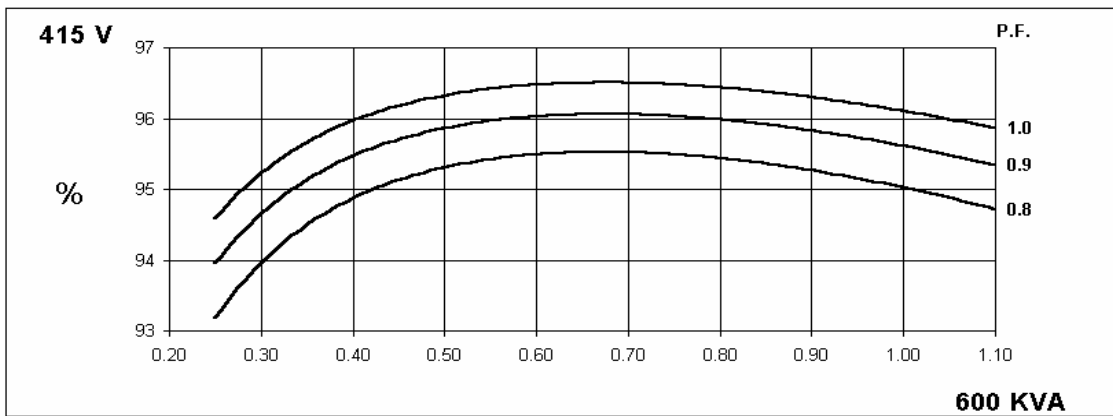
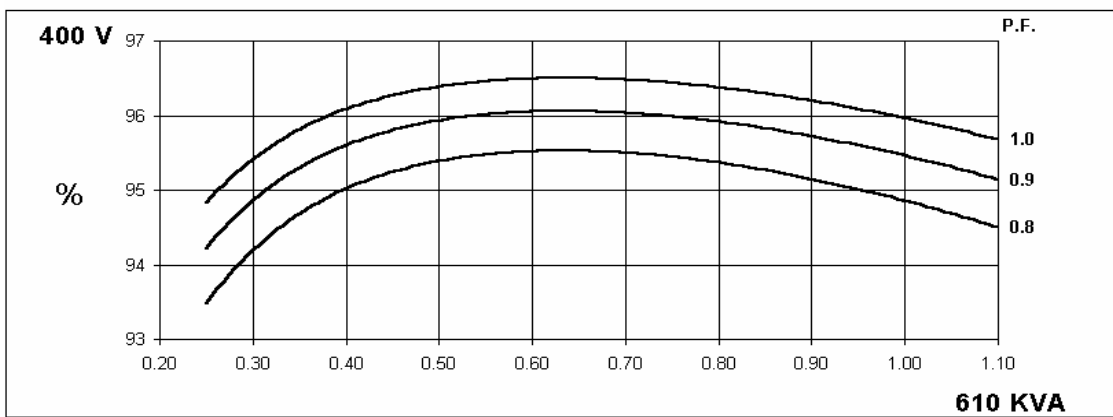
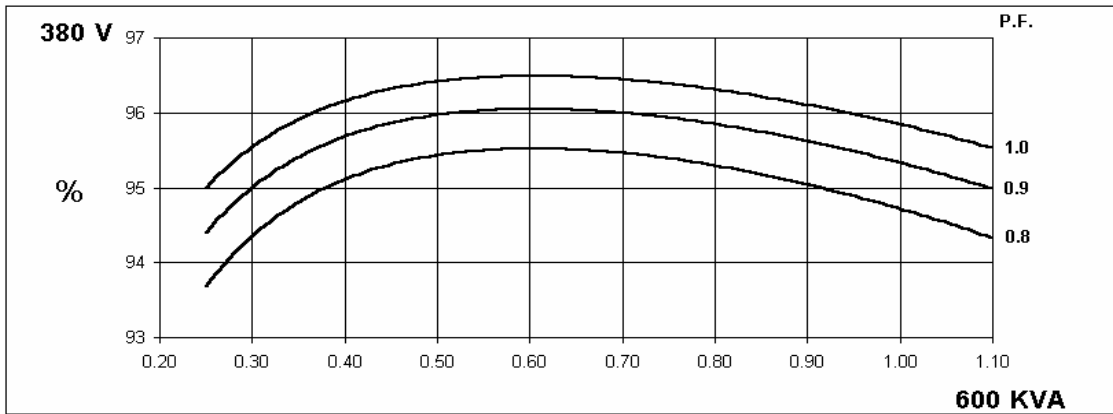

60
Hz

HCI534E/544E
Winding 311

STAMFORD

THREE PHASE EFFICIENCY CURVES

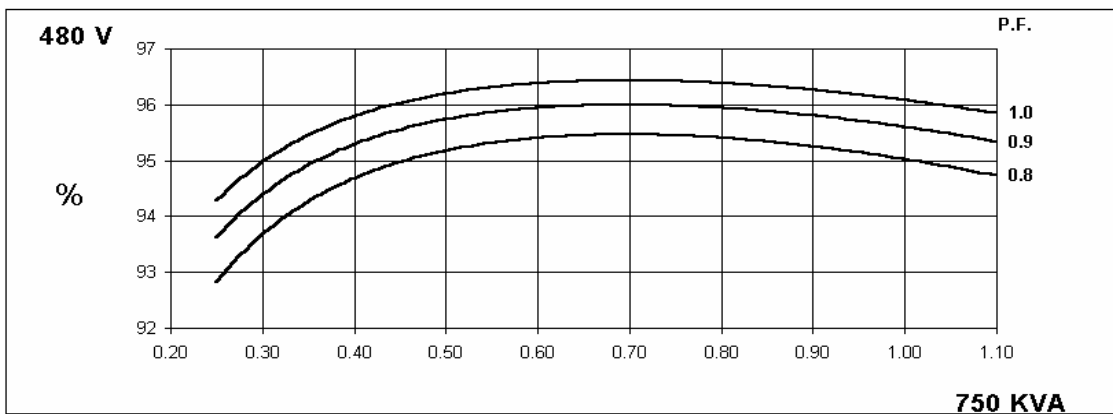
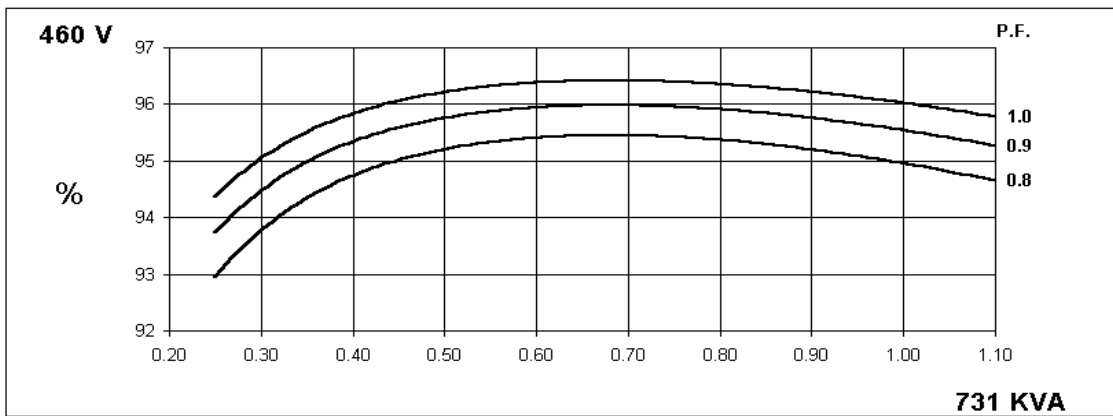
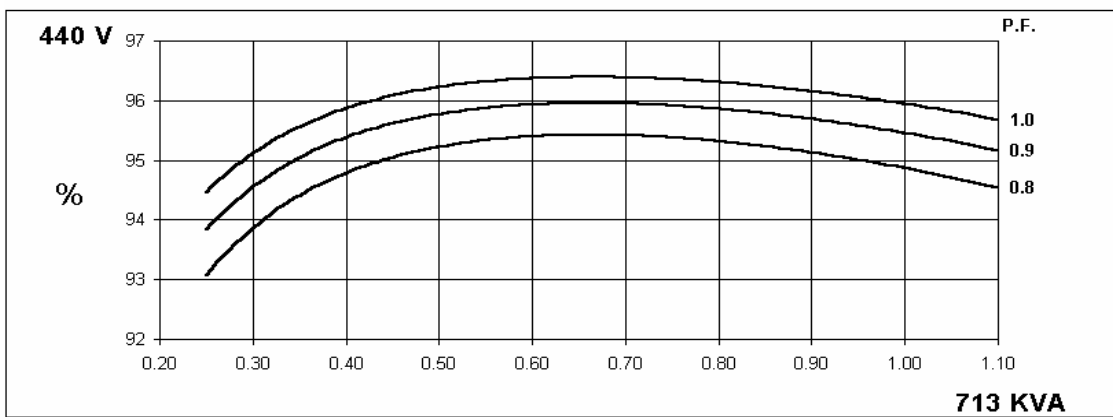
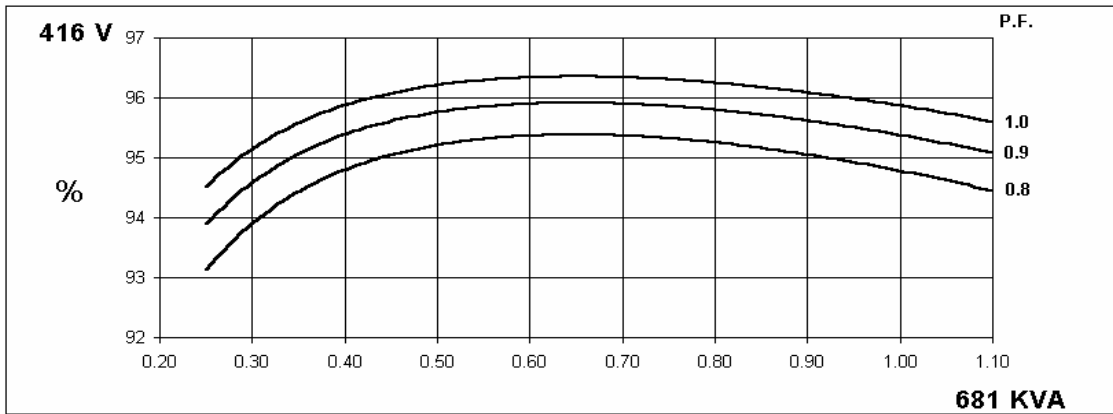

Locked Rotor Motor Starting Curve

50
Hz

MX

SX

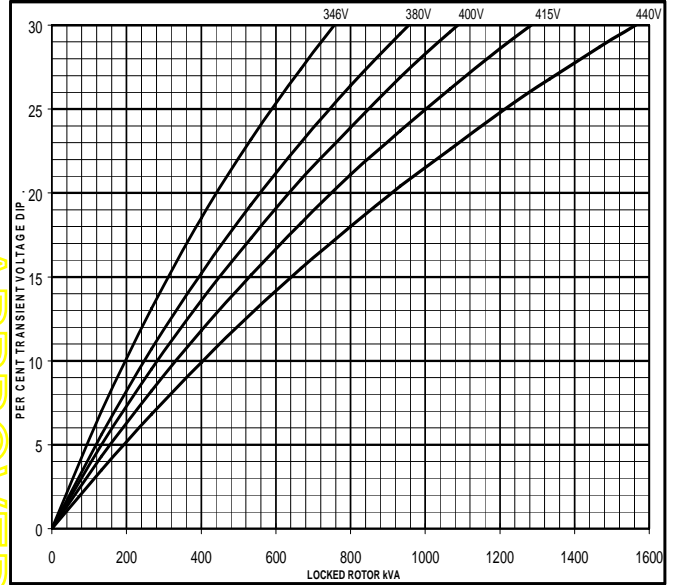
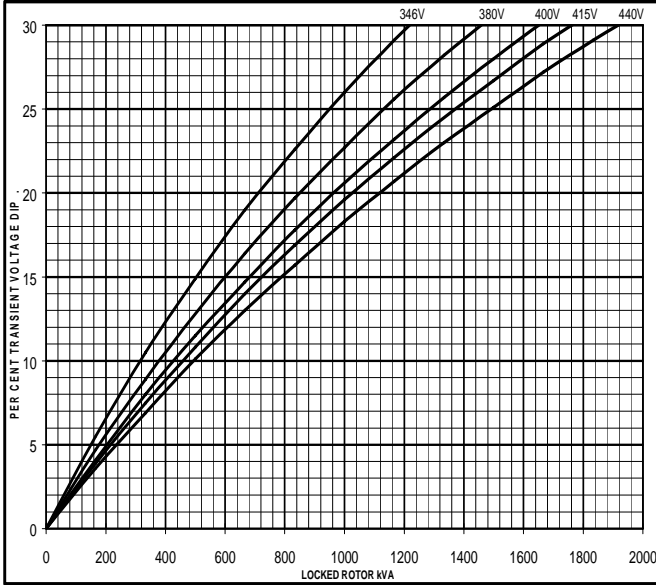

60
Hz

MX

SX

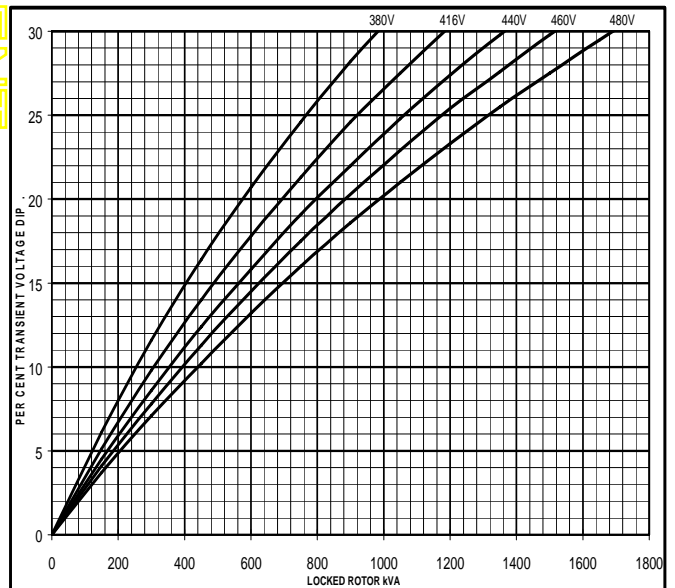
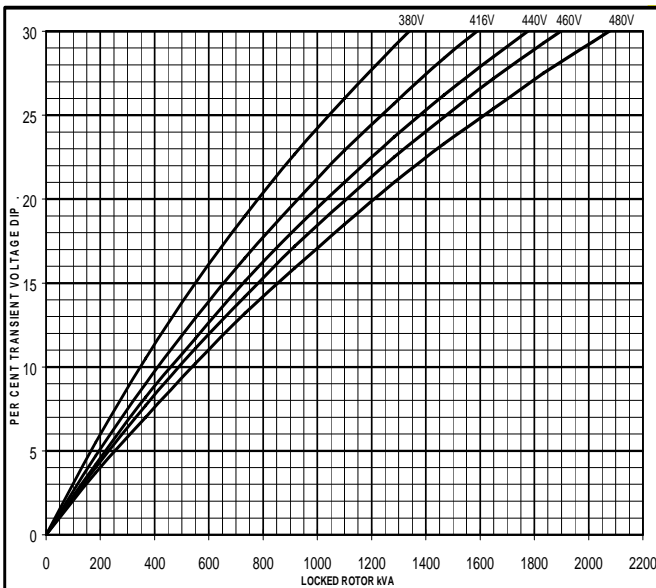

APPROVED DOCUMENT

**Three-phase Short Circuit Decrement Curve. No-load Excitation at Rated Speed
Based on star (wye) connection.**

50
Hz

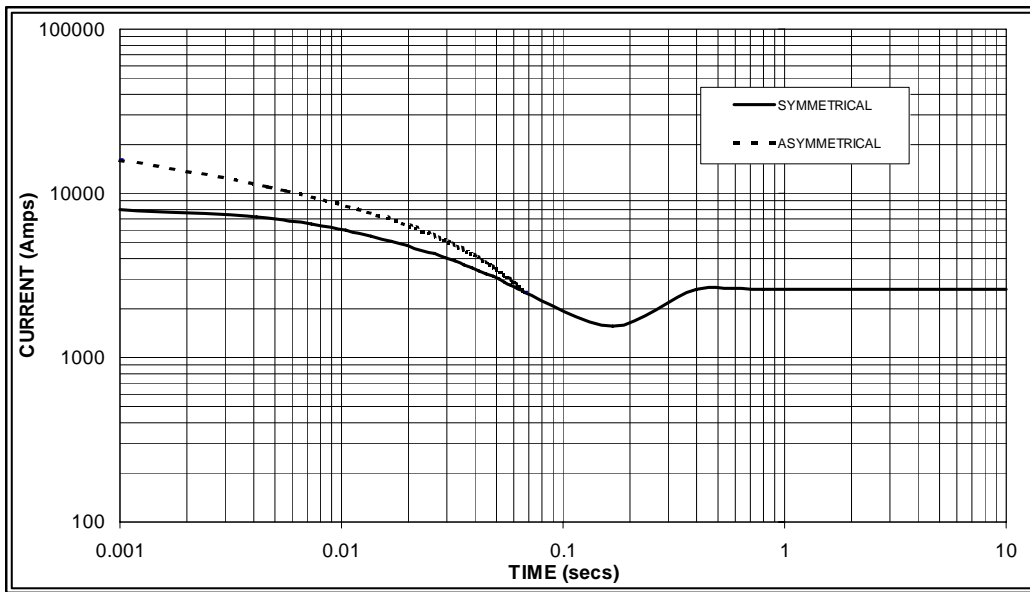

Sustained Short Circuit = 2,600 Amps



60
Hz

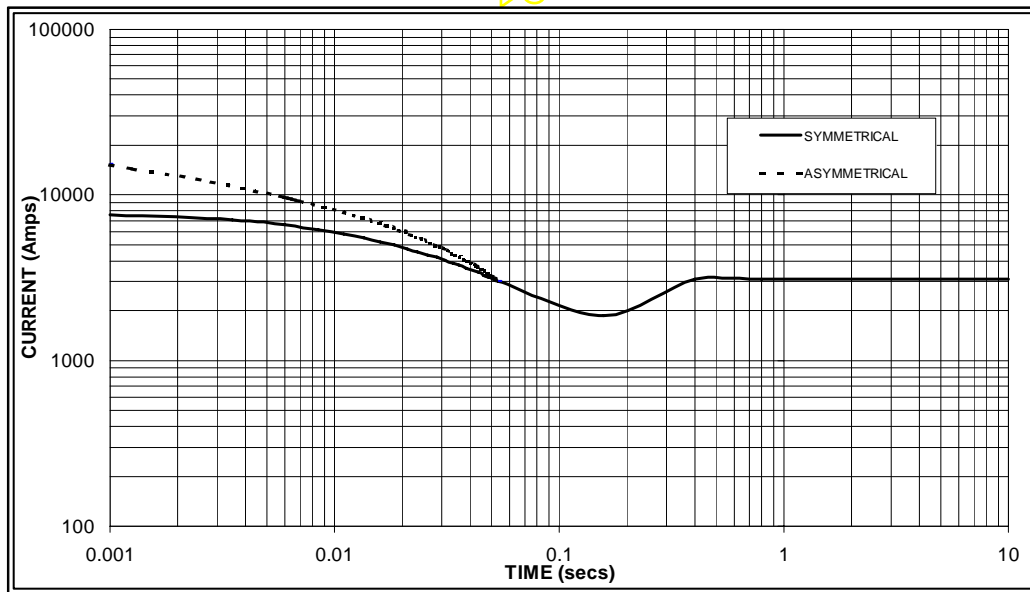

Sustained Short Circuit = 3,100 Amps

Note 1

The following multiplication factors should be used to adjust the values from curve between time 0.001 seconds and the minimum current point in respect of nominal operating voltage :

50Hz		60Hz	
Voltage	Factor	Voltage	Factor
380v	X 1.00	416v	X 1.00
400v	X 1.06	440v	X 1.06
415v	X 1.09	460v	X 1.12
440v	X 1.12	480v	X 1.20

The sustained current value is constant irrespective of voltage level

Note 2

The following multiplication factor should be used to convert the values calculated in accordance with NOTE 1 to those applicable to the various types of short circuit :

	3-phase	2-phase L-L	1-phase L-N
Instantaneous	x 1.00	x 0.87	x 1.30
Minimum	x 1.00	x 1.80	x 3.20
Sustained	x 1.00	x 1.50	x 2.50
Max. sustained duration	10 sec.	5 sec.	2 sec.

All other times are unchanged

Note 3

Curves are drawn for Star (Wye) connected machines. For other connection the following multipliers should be applied to current values as shown :

Parallel Star = Curve current value X 2

Series Delta = Curve current value X 1.732

HCI534E/544E

STAMFORD

Winding 311 0.8 Power Factor

RATINGS

Class - Temp Rise	Cont. F - 105/40°C				Cont. H - 125/40°C				Standby - 150/40°C				Standby - 163/27°C				
50 Hz	Series Star (V)	380	400	415	440	380	400	415	440	380	400	415	440	380	400	415	440
	Parallel Star (V)	190	200	208	220	190	200	208	220	190	200	208	220	190	200	208	220
	Series Delta (V)	220	230	240	254	220	230	240	254	220	230	240	254	220	230	240	254
kVA	550	560	550	550	600	610	600	600	636	640	636	636	660	665	660	660	
kW	440	448	440	440	480	488	480	480	509	512	509	509	528	532	528	528	
Efficiency (%)	95.0	95.1	95.2	95.3	94.7	94.9	95.0	95.2	94.5	94.7	94.8	95.0	94.3	94.5	94.7	94.9	
kW Input	463	471	462	462	507	514	505	504	538	541	537	536	560	563	558	556	

60 Hz	Series Star (V)	416	440	460	480	416	440	460	480	416	440	460	480	416	440	460	480
	Parallel Star (V)	208	220	230	240	208	220	230	240	208	220	230	240	208	220	230	240
	Delta (V)	240	254	266	277	240	254	266	277	240	254	266	277	240	254	266	277
kVA	625	650	663	675	681	713	731	750	719	750	780	800	738	769	798	819	
kW	500	520	530	540	545	570	585	600	575	600	624	640	590	615	638	655	
Efficiency (%)	95.0	95.1	95.2	95.3	94.8	94.9	95.0	95.0	94.6	94.7	94.8	94.8	94.5	94.6	94.7	94.8	
kW Input	526	547	557	567	575	601	616	632	608	634	658	675	625	650	674	691	

DIMENSIONS

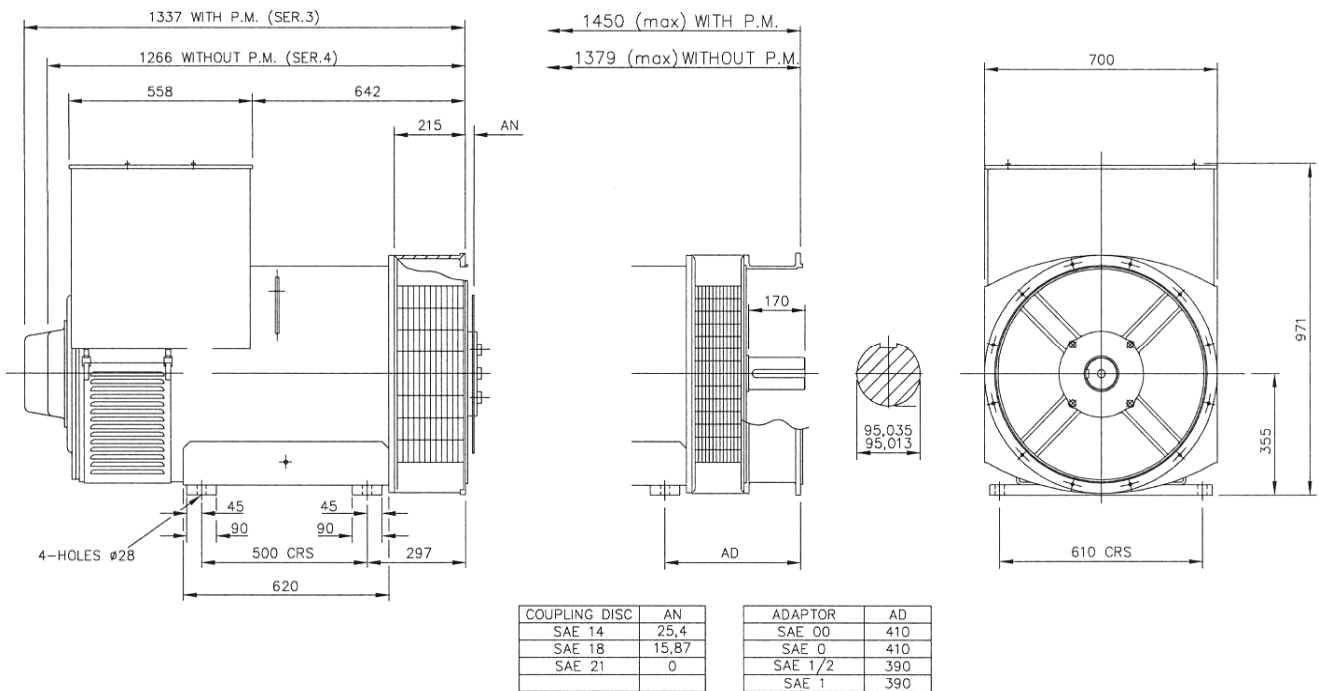

APPROVED DOCUMENT

STAMFORD

Head Office Address:
Barnack Road, Stamford
Lincolnshire, PE9 2NB
United Kingdom
Tel: +44 (0) 1780 484000
Fax: +44 (0) 1780 484100

www.cumminsgeneratortechnologies.com

Copyright 2010, Cummins Generator Technologies Ltd, All Rights Reserved
Stamford and AvK are registered trade marks of Cummins Generator Technologies Ltd
Cummins and the Cummins logo are registered trade marks of Cummins Inc.

STAMFORD®

HCI534F/544F - Winding 17

Technical  Data Sheet

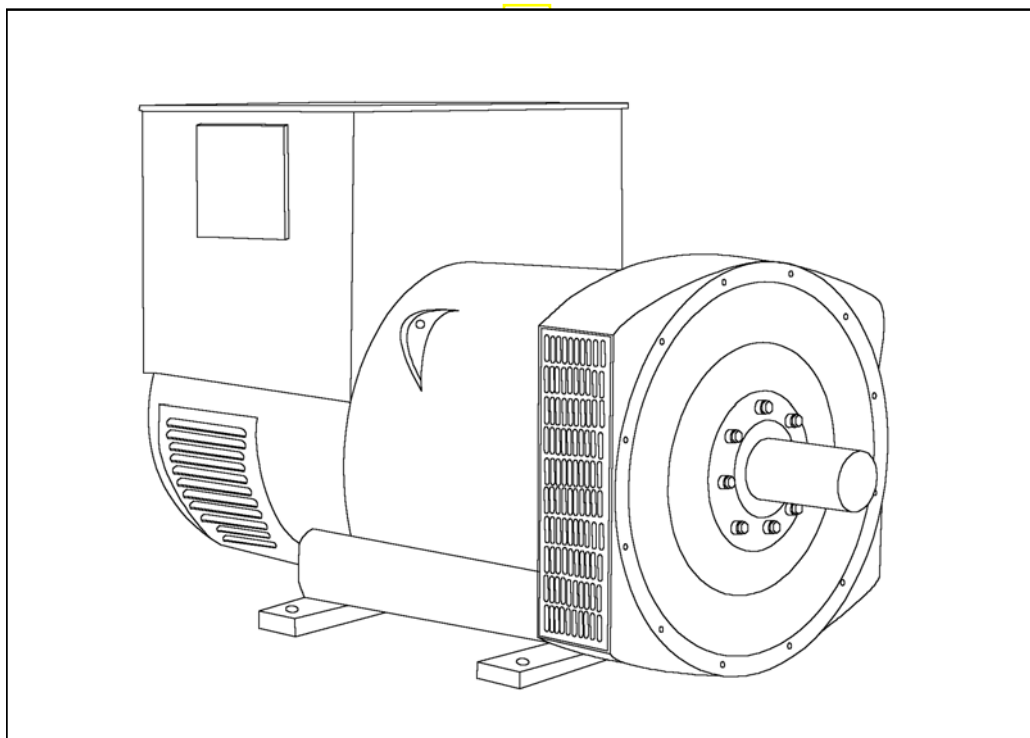

HCI534F/544F

SPECIFICATIONS & OPTIONS

STAMFORD

STANDARDS

Stamford industrial generators meet the requirements of BS EN 60034 and the relevant section of other international standards such as BS5000, VDE 0530, NEMA MG1-32, IEC34, CSA C22.2-100, AS1359. Other standards and certifications can be considered on request.

VOLTAGE REGULATORS

AS440 AVR - STANDARD

With this self-excited system the main stator provides power via the Automatic Voltage Regulator (AVR) to the exciter stator. The high efficiency semi-conductors of the AVR ensure positive build-up from initial low levels of residual voltage.

The exciter rotor output is fed to the main rotor through a three-phase full-wave bridge rectifier. The rectifier is protected by a surge suppressor against surges caused, for example, by short circuit or out-of-phase paralleling.

The AS440 will support a range of electronic accessories, including a 'droop' Current Transformer (CT) to permit parallel operation with other ac generators.

MX341 AVR

This sophisticated AVR is incorporated into the Stamford Permanent Magnet Generator (PMG) control system.

The PMG provides power via the AVR to the main exciter, giving a source of constant excitation power independent of generator output. The main exciter output is then fed to the main rotor, through a full wave bridge, protected by a surge suppressor. The AVR has in-built protection against sustained over-excitation, caused by internal or external faults. This de-excites the machine after a minimum of 5 seconds.

An engine relief load acceptance feature can enable full load to be applied to the generator in a single step.

If three-phase sensing is required with the PMG system the MX321 AVR must be used.

We recommend three-phase sensing for applications with greatly unbalanced or highly non-linear loads.

MX321 AVR

The most sophisticated of all our AVRs combines all the features of the MX341 with, additionally, three-phase rms sensing, for improved regulation and performance.

Over voltage protection is built-in and short circuit current level adjustments is an optional facility.

WINDINGS & ELECTRICAL PERFORMANCE

All generator stators are wound to 2/3 pitch. This eliminates triplen (3rd, 9th, 15th ...) harmonics on the voltage waveform and is found to be the optimum design for trouble-free supply of non-linear loads. The 2/3 pitch design avoids excessive neutral currents sometimes seen with higher winding pitches, when in parallel with the mains. A fully connected damper winding reduces oscillations during paralleling. This winding, with the 2/3 pitch and carefully selected pole and tooth designs, ensures very low waveform distortion.

TERMINALS & TERMINAL BOX

Standard generators are 3-phase reconnectable with 12 ends brought out to the terminals, which are mounted on a cover at the non-drive end of the generator. A sheet steel terminal box contains the AVR and provides ample space for the customers' wiring and gland arrangements. It has removable panels for easy access.

SHAFT & KEYS

All generator rotors are dynamically balanced to better than BS6861:Part 1 Grade 2.5 for minimum vibration in operation. Two bearing generators are balanced with a half key.

INSULATION/IMPREGNATION

The insulation system is class 'H'.

All wound components are impregnated with materials and processes designed specifically to provide the high build required for static windings and the high mechanical strength required for rotating components.

QUALITY ASSURANCE

Generators are manufactured using production procedures having a quality assurance level to BS EN ISO 9001.

The stated voltage regulation may not be maintained in the presence of certain radio transmitted signals. Any change in performance will fall within the limits of Criteria 'B' of EN 61000-6-2:2001. At no time will the steady-state voltage regulation exceed 2%.

DE RATES

All values tabulated on page 6 are subject to the following reductions

5% when air inlet filters are fitted.

3% for every 500 metres by which the operating altitude exceeds 1000 metres above mean sea level.

3% for every 5 C by which the operational ambient temperature exceeds 40 C.

Note: Requirement for operating in an ambient exceeding 60 C must be referred to the factory.

NB Continuous development of our products entitles us to change specification details without notice, therefore they must not be regarded as binding.

Front cover drawing typical of product range.

APPROVED DOCUMENT

HCI534F/544F

STAMFORD

WINDING 17

CONTROL SYSTEM	SEPARATELY EXCITED BY P.M.G.		
A.V.R.	MX321	MX341	
VOLTAGE REGULATION	± 0.5 %	± 1.0 %	With 4% ENGINE GOVERNING
SUSTAINED SHORT CIRCUIT	REFER TO SHORT CIRCUIT DECREMENT CURVES (page 5)		
CONTROL SYSTEM	SELF EXCITED		
A.V.R.	AS440		
VOLTAGE REGULATION	± 1.0 %		With 4% ENGINE GOVERNING
SUSTAINED SHORT CIRCUIT	WILL NOT SUSTAIN A SHORT CIRCUIT		
INSULATION SYSTEM	CLASS H		
PROTECTION	IP23		
RATED POWER FACTOR	0.8		
STATOR WINDING	DOUBLE LAYER LAP		
WINDING PITCH	TWO THIRDS		
WINDING LEADS	12		
STATOR WDG. RESISTANCE	0.0049 Ohms PER PHASE AT 22°C SERIES STAR CONNECTED		
ROTOR WDG. RESISTANCE	2.16 Ohms at 22°C		
EXCITER STATOR RESISTANCE	17 Ohms at 22°C		
EXCITER ROTOR RESISTANCE	0.092 Ohms PER PHASE AT 22°C		
R.F.I. SUPPRESSION	BS EN 61000-6-2 & BS EN 61000-6-4, VDE 0875G, VDE 0875N. refer to factory for others		
WAVEFORM DISTORTION	NO LOAD < 1.5% NON-DISTORTING BALANCED LINEAR LOAD < 5.0%		
MAXIMUM OVERSPEED	2250 Rev/Min		
BEARING DRIVE END	BALL. 6220 (ISO)		
BEARING NON-DRIVE END	BALL. 6314 (ISO)		
	1 BEARING	2 BEARING	
WEIGHT COMP. GENERATOR	1685 kg	1694 kg	
WEIGHT WOUND STATOR	805 kg	805 kg	
WEIGHT WOUND ROTOR	684 kg	655 kg	
WR ² INERTIA	10.033 kgm ²	9.7551 kgm ²	
SHIPPING WEIGHTS in a crate	1775 kg	1780 kg	
PACKING CRATE SIZE	166 x 87 x 124 (cm)	166 x 87 x 124 (cm)	
TELEPHONE INTERFERENCE	THF<2%	TIF<50	
COOLING AIR	1.035 m ³ /sec 2202 cfm		
VOLTAGE SERIES STAR	600V		
VOLTAGE PARALLEL STAR	300V		
VOLTAGE SERIES DELTA	346V		
KVA BASE RATING FOR REACTANCE VALUES	825		
X _d DIR. AXIS SYNCHRONOUS	2.44		
X' _d DIR. AXIS TRANSIENT	0.11		
X'' _d DIR. AXIS SUBTRANSIENT	0.09		
X _q QUAD. AXIS REACTANCE	1.95		
X'' _q QUAD. AXIS SUBTRANSIENT	0.23		
X _L LEAKAGE REACTANCE	0.04		
X ₂ NEGATIVE SEQUENCE	0.16		
X ₀ ZERO SEQUENCE	0.07		
REACTANCES ARE SATURATED		VALUES ARE PER UNIT AT RATING AND VOLTAGE INDICATED	
T' _d TRANSIENT TIME CONST.	0.08 s		
T'' _d SUB-TRANSTIME CONST.	0.012 s		
T' _{do} O.C. FIELD TIME CONST.	2.5 s		
T _a ARMATURE TIME CONST.	0.019 s		
SHORT CIRCUIT RATIO	1/X _d		

HCI534F/544F

STAMFORD

Winding 17

SX

Locked Rotor Motor Starting Curves



OCU

MX



HCI534F/544F
Winding 17

STAMFORD

THREE PHASE EFFICIENCY CURVES

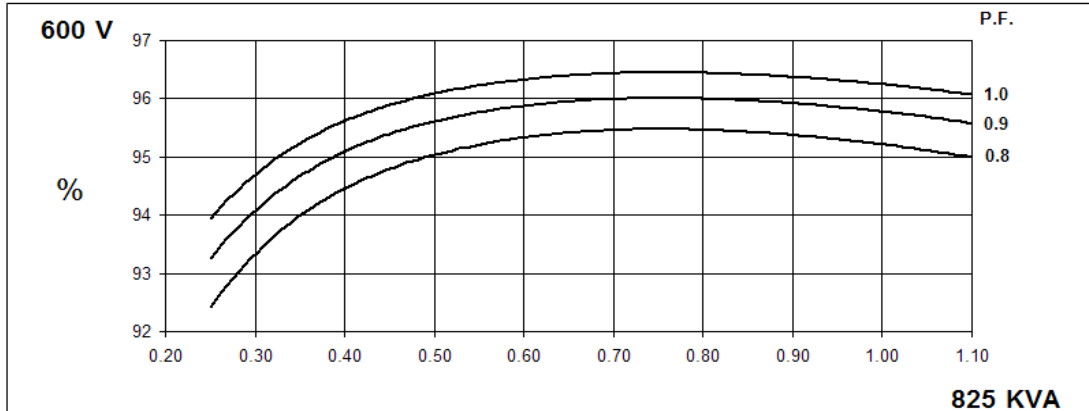

Three-phase Short Circuit Decrement Curve. No-load Excitation at Rated Speed Based on star (wye) connection.

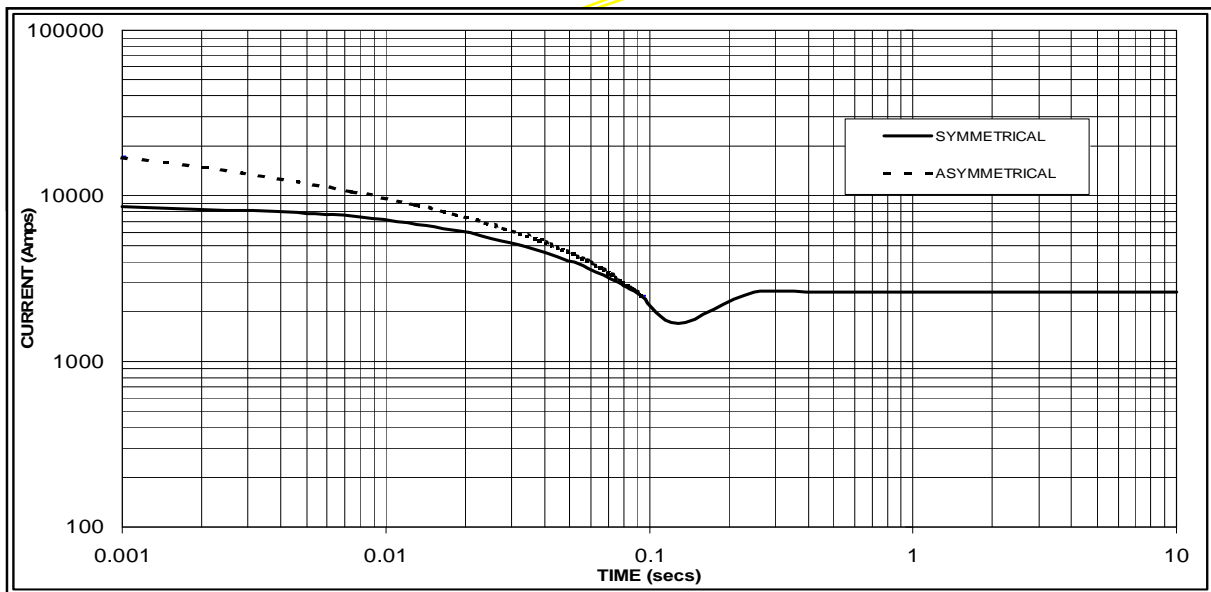

Sustained Short Circuit = 2600 Amps

Note

The following multiplication factor should be used to convert the values from curve for the various types of short circuit :

	3-phase	2-phase L-L	1-phase L-N
Instantaneous	x 1.00	x 0.87	x 1.30
Minimum	x 1.00	x 1.80	x 3.20
Sustained	x 1.00	x 1.50	x 2.50
Max. sustained duration	10 sec.	5 sec.	2 sec.

All other times are unchanged

HCI534F/544F

Winding 17 / 0.8 Power Factor

STAMFORD

60Hz

RATINGS

Class - Temp Rise	Cont. F - 105/40°C	Cont. H - 125/40°C	Standby - 150/40°C	Standby - 163/27°C
Series Star (V)	600	600	600	600
Parallel Star (V)	300	300	300	300
Series Delta (V)	346	346	346	346
kVA	750	825	875	906
kW	600	660	700	725
Efficiency (%)	95.4	95.2	95.1	95.0
kW Input	629	692	734	760

APPROVED

DIMENSIONS

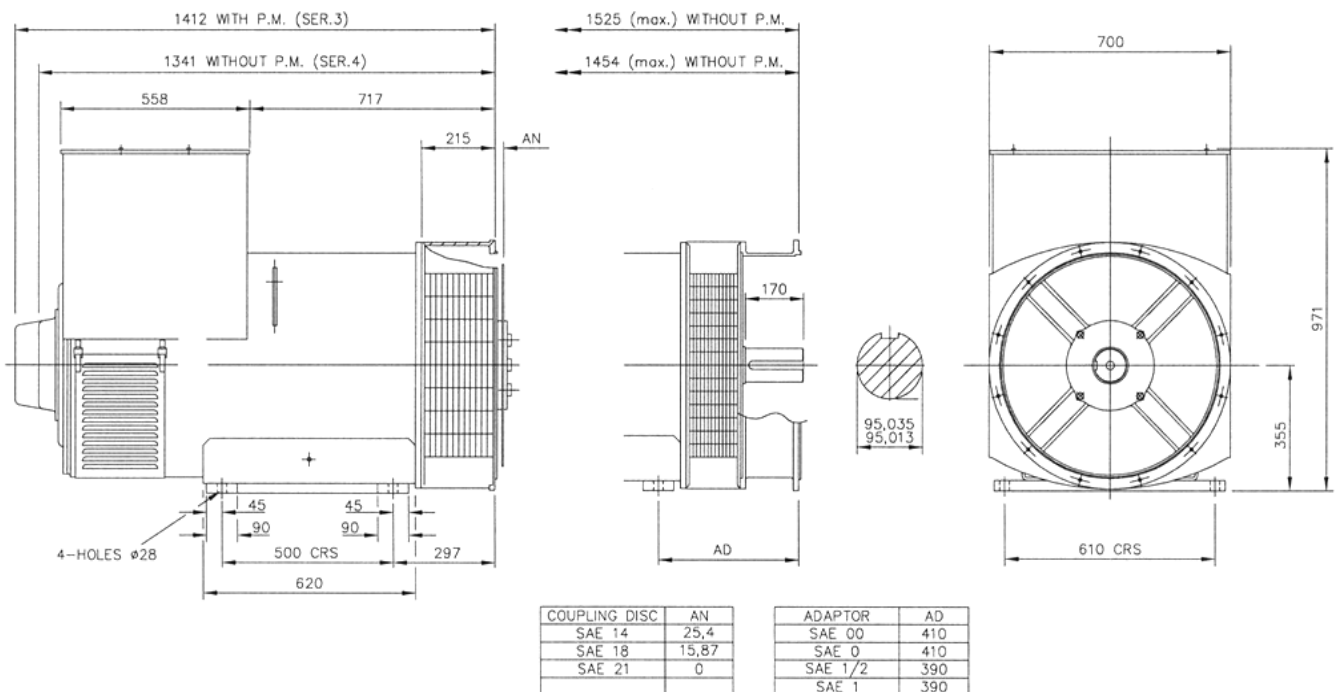

APPROVED DOCUMENT

STAMFORD

Head Office Address:
Barnack Road, Stamford
Lincolnshire, PE9 2NB
United Kingdom
Tel: +44 (0) 1780 484000
Fax: +44 (0) 1780 484100

www.cumminsgeneratortechnologies.com

Copyright 2010, Cummins Generator Technologies Ltd, All Rights Reserved
Stamford and AvK are registered trade marks of Cummins Generator Technologies Ltd
Cummins and the Cummins logo are registered trade marks of Cummins Inc.

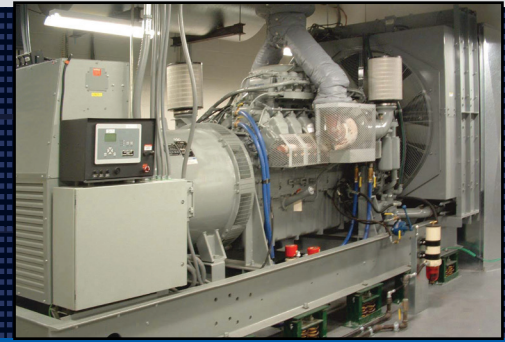

A highly advanced integrated genset control system, this device provides genset control, transfer switch control, metering, protection, and programmable logic in a simple, easy-to-use, reliable, rugged, and cost effective package.

FEATURES

- Generator metering (includes three-phase mains)
- Engine and generator protection: 27, 32R, 40Q, 59, 810/U
- Optional enhanced generator protection: 47, 51, 78, and 81ROCOF
- Load sharing and generator sequencing (via LSM-200 Load Share Module)
- Var sharing over Ethernet (via LSM-200)
- BESTCOMSP^{Plus}® Software
 - Programming and setup
 - Intuitive and powerful
 - Remote control and monitoring
 - Programmable logic
 - USB communications
- Automatic transfer switch control
- Automatic synchronizer (optional)
- Exercise timer
- SAE J1939 engine ECU communications
- Automatic generator configuration detection
- Expandable functionality via add-on modules
 - [LSM-200 Load Share Module](#)
 - [CEM-200 Contact Expansion Module](#)
 - [AEM-200 Analog Expansion Module](#)
- Multilingual capability
- Remote communications to Basler's RDP-110 (remote display panel)
- Sixteen programmable contact inputs
- Up to 15 contact outputs: 3 contacts rated for 30 Adc and up to 12 programmable contacts rated for 2 Adc

BENEFITS

- Provides integrated engine-genset control, protection, and metering in a single package.
- The Offline Simulator, provided in BESTlogic™ Plus, helps test and troubleshoot logic without the need for expensive hardware.
- Flexible programmable logic and programmable I/O make it easy to expand the DGC-200's inputs and outputs with the CEM-200 (Contact Expansion Module) and the AEM-200 (Analog Expansion Module). This saves time and money by eliminating unnecessary external PLCs and control relaying.

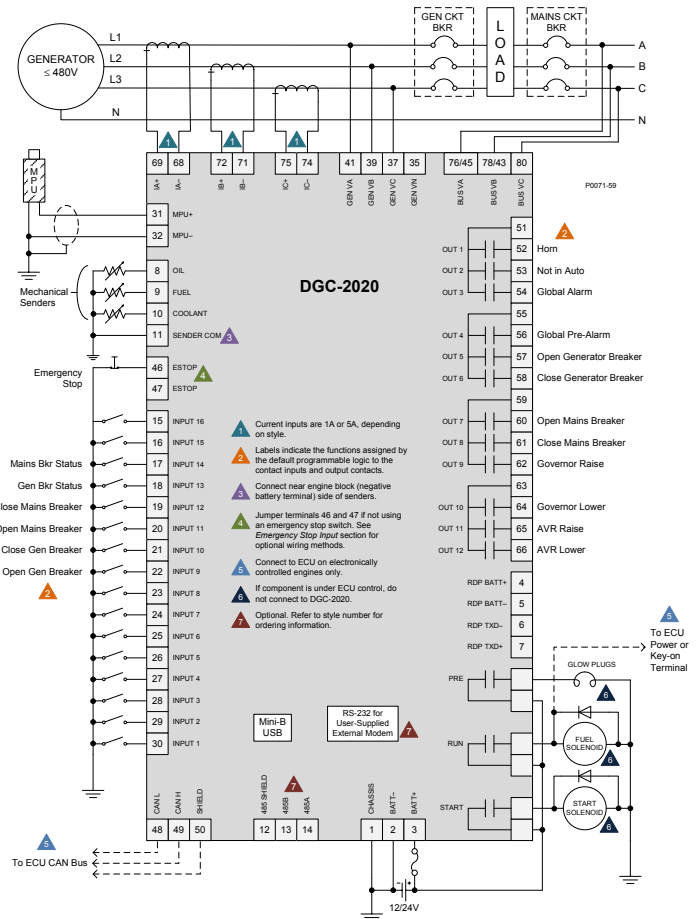

Figure 1 - DGC-200 Connection Diagram for a Typical Application

Visit [WWW.BASLER.COM](http://www.basler.com)
FOR ADDITIONAL INFORMATION.

SPECIFICATIONS

Power Supply

Nominal:	12 or 24 Vdc
Range:	6 to 32 Vdc
Battery Ride Through:	Starting at 10 Vdc, withstands cranking ride-through down to 0 V for 50 ms

Power Consumption

Sleep Mode:	5 W
Normal Operational Mode:	7.9 W
Maximum:	14.2 W

Current Sensing

1 A Sensing:	0.02 to 1.0 Aac, continuous 2 Aac for 1 second
5 A Sensing:	0.1 to 5.0 Aac, continuous 10 Aac for 1 second
Burden:	1 VA

Voltage Sensing

Range:	12 to 576 Vrms L-L
Frequency Range:	10 to 72 Hz for 50/60 Hz style, 10 to 480 Hz for 400 Hz style
Burden:	1 VA
One-second Rating:	720 Vrms

Contact Sensing

Contact Inputs (16):	Accepts normally open (N.O.), Dry Contacts, programmable
Emergency Stop:	Normally closed (N.C.), Dry Contact

Engine Speed Sensing

Magnetic Pickup:	
Voltage Range:	6 to 70 Vpp
Frequency Range:	32 to 10,000 Hz
Generator Frequency:	
Generator Voltage Range:	12 to 576 Vrms
Via ECU over J1939	

Resistive Senders

Fuel Level Sender:	0 to 250 Ω nominal
Coolant Temp Sender:	10 to 2,750 Ω nominal
Oil Pressure Sender:	0 to 250 Ω nominal

Output Contacts

Fuel Solenoid, Engine Crank, Pre-Start Relays Rating:	30 Adc at 28 Vdc- make, break, and carry
Programmable Relays:	Up to 12
Rating:	2 Adc at 28 Vdc- make, break, and carry

Protection

Generator:	27, 32R, 40Q, 59, 810/U (standard) 47, 51, 78, 81 ROCOF (optional)
Engine:	Oil pressure, coolant temperature, overcrank, ECU-specific elements, and diagnostic reporting.

Agency Approvals

- CSA certified, NFPA compliant, CE compliant,
- UL recognized (Hazardous Location certification available upon request), EAC certified

Communication

USB Port:	USB 2.0, Mini-B jack
RS-485 (optional):	9600 baud, 8 data bits, no parity
RDP-110 (optional):	4,000 ft (1,219 m) max wire length, 20 AWG (0.52 mm ²) min wire size
Modem (optional):	DB-9 connector (male)
CAN bus:	250 kb/s communication rate, 1.5 to 3 Vdc differential bus

Environmental

Operating Temp:	-40°C to 70°C (-40°F to 158°F)
Storage Temp:	-40°C to 85°C (-40°F to 185°F)
Humidity:	IEC 68-2-38
Salt Fog:	ASTM B 17-73, IEC 68-2-11
Ingress Protection:	IEC IP54 for front panel
Shock:	15 G in three perpendicular planes
Vibration:	
5 to 29 Hz:	1.5 G peak
29 to 52 Hz:	0.036" (0.914 mm) double amplitude
52 to 500 Hz:	5 G peak

Physical

Weight:	4.4 lb (2 kg)
Dimensions (WxHxD):	11.77 x 8.27 x 2.69 inches (299 x 210 x 69 mm)

For complete specifications, download the instruction manual at www.basler.com.

STYLE CHART

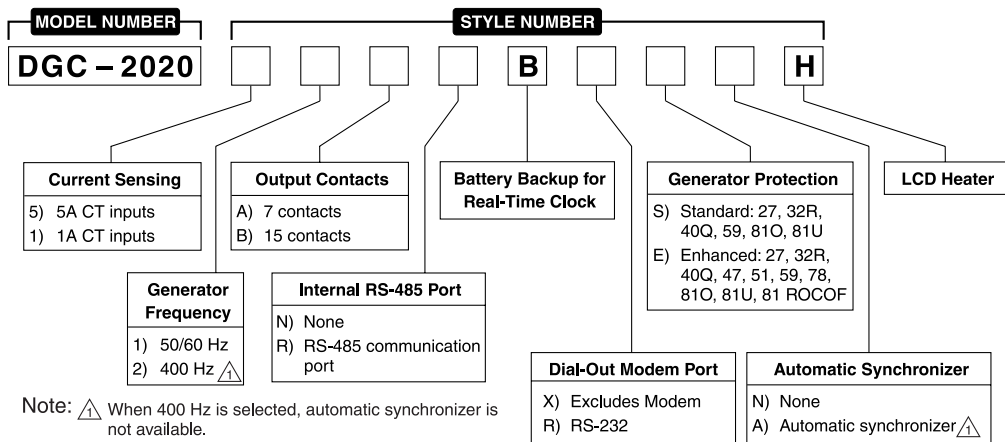

RELATED PRODUCTS

- [BE1-11g Generator Protection System](#)
 - A complete generator protection system.
- [DECS-250 Digital Excitation Control System](#)
 - Total control in a compact package provides precise voltage, var and power factor regulation, exceptional system response, and generator protection.

ACCESSORIES

- [AEM-2020 Analog Expansion Module](#)
 - Easily increases the functionality by seamlessly adding analog inputs and outputs.
- [CEM-2020, CEM-2020H Contact Expansion Module](#)
 - Each module adds 10 inputs and up to 24 outputs that are easily programmed through BESTCOMSPUs[®] for easy integration into the system.
- [LSM-2020 Load Share Module](#)
 - The simple-to-use LSM-2020 easily adds paralleling capabilities with little effort and expense.
- [RDP-110 Remote Display Panel](#)
 - Provides remote alarm and pre-alarm indication and annunciation of system status, easily meeting the annunciation requirements of NFPA-110 applications.



ISO 9001-2008
Highland, IL USA Wasselonne, France
Taylor, TX USA Suzhou, China
Basler Plastics, LLC



12570 State Route 143, Highland, Illinois 62249-1074 USA
Tel +1 618.654.2341 Fax +1 618.654.2351
email:info@basler.com www.basler.com

P.A.E. Les Pins, 67319 Wasselonne Cedex, FRANCE
Tel +33 3.88.87.1010 Fax +33 3.88.87.0808
e-mail: franceinfo@basler.com

No. 59 Heshun Road Loufeng District (N),
Suzhou Industrial Park, 215122, Suzhou, P.R.China
Tel +86(0)512.8227.2888 Fax +86(0)512.8227.2887
e-mail: chinainfo@basler.com

111 North Bridge Road #15-06 Peninsula Plaza
Singapore 179098
Tel +65 68.44.6445 Fax +65 68.44.8902
e-mail: singaporeinfo@basler.com

Tmax-Molded Case Circuit Breakers

T7 1200A Frame

AC Circuit Breakers and Switches

3 and 4 Pole

Motor Circuit Protectors

Higher Performances in Less Space

Field Installable Accessories and Trip Units



Dimensions 3P Fixed Version 10.55H x 8.26W x 6.06D

Weight 21.4 (lbs)

Compliance with Standards

UL 489

CSA C22.2 No.5.1

IEC 60947-2

Standards

EC directive:

– “Low Voltage Directives” (LVD) no. 73/23 EEC

– “Electromagnetic Compatibility Directive” (EMC) no.89/336 EEC

The ABB Quality System complies with the international ISO 9001 - 2000 Standard (model for quality assurance in design, development, construction, and installation and service) and with the equivalent European EN ISO 9001 and Italian UNI EN ISO 9001 Standards

Interrupting ratings (RMS sym. kAmps)		T7		
Continuous Current Rating		1200		
Number of Poles		3-4		
		S	H	L
AC				
	240V	65	100	150
	480V	50	65	100
	600V	25	50	65



Company Quality Systems and Environmental Systems

The new Tmax series has a hologram on the front, obtained using special anti-imitation techniques, which guarantees the quality and that the circuit breaker is an original ABB product.

Attention to protection of the environment and to health and safety in the work place is another priority commitment for ABB and, as confirmation of this, the company environmental management system has been certified by RINA in 1997, in conformity with the international ISO 14001 Standard. This certification has been integrated in 1999 with the Management System for Health and Safety in the workplace, according to OHSAS 18001 (British Standards), obtaining one of the first certification of integrated management System, QES (Quality, Environment,

Safety) issued by RINA. ABB - the first industry in the electro-mechanical section in Italy to obtain this recognition - thanks to a revision of the production process with an eye to ecology has been able to reduce the consumption of raw materials and waste from processing by 20%. ABB's commitment to safeguarding the environment is also shown in a concrete way by the Life Cycle Assessments of its products carried out directly by the ABB Research and Development in collaboration with the ABB Research Center. Selection of materials, processes and packing materials is made optimizing the true environmental impact of the product, also foreseeing the possibility of its being recycled.

Mounting

Fixed
Drawout

Connections

Busbar connection or compression lugs
Pressure-type terminals for bare cables
Rear connections

Trip Unit

PR231/P, PR232/P, PR331DS, and PR332DS/P electronic trip unit

Auxiliary Devices for Indication and Control

- Auxiliary contacts - AUX
- Undervoltage release - UVR
- Shunt trip - SOR
- Terminal covers
- Padlock provision - PLL
- Direct rotary handle - RHD
- Key lock - KLF
- Early auxiliary contact - AUE
- Transmitted rotary handle - RHE
- Front extended terminal - EF
- Front terminal for copper-aluminum - FC CuAl
- Front extended spread terminal - ES
- Rear orientated terminal - R
- Phase separators
- Residual current relay (IEC Only)



ABB Inc.

1206 Hatton Road
Wichita Falls, TX 76302
For more information and
the location of your local
field office please go to
www.abb-control.com

Annex to the
technical catalog



Tmax T8

Low voltage molded case
circuit breaker up to 3000 A

UL 489 and CSA C22.2 Standard



1SDC210026D0201 – 2008 Edition



ABB

Main characteristics

The Tmax family, conforming to the UL 489 and CSA C22.2 No. 5.1 Standards, is enriched with the Tmax T8 size, which allows 3000 A to be reached. Also available in the 1600 A, 2000 A and 2500 A frames, Tmax T8 is equipped with the same electronic trip units as Tmax T7, thereby guaranteeing extremely high performances able to satisfy all installation requirements. Adequately sized for the performances offered (W=16.8 / D=11.2 / H=15.0 in). Tmax T8 is able to interrupt the following short-circuit currents: 125 kA@480 V and 100 kA@600 V.



Main characteristics

General characteristics

The Tmax T8 size has both circuit breakers and molded case switches (MCS). The following tables show the main characteristics of these ranges.

Circuit breakers for power distribution

			Tmax T8
Frame size		[A]	1600/2000/2500/3000
Number of poles		[No]	3/4
Rated voltage	(AC) 50-60 Hz	[V]	600
	(DC)	[V]	–
Test voltage (1 min) 50-60 Hz		[V]	3000
Interrupting ratings		[kA rms]	V
	240 V AC	[kA rms]	125
	480 V AC	[kA rms]	125
	600 V AC	[kA rms]	100
Trip units	Electronic	PR232/P-T8	■
		PR331/P	■
		PR332/P	■
Dimensions fixed version (3p)	H	[in-mm]	15.0 - 382
	W	[in-mm]	16.8 - 427
	D	[in-mm]	11.2 - 282
Mechanical life		[operations]	15000
Weight (fixed 3p)	1600/2000/2500 A	[lbs]	161
	3000 A	[lbs]	236

Molded case switches (MCS)

The Tmax T8 MCS are derived from the corresponding circuit breakers, of which they keep the overall dimensions, the versions, the fixing systems and the possibility of mounting accessories unchanged. This version only differs from the circuit breakers in the absence of the protection trip units. All molded case switches comply with the UL 489 and CSA C22.2 Standards and are self-protected.

			Tmax T8V-D
Rating		[A]	2000/2500/3000
Poles		[No]	3/4
Magnetic override		[A]	40000
Rated voltage	AC (50-60 Hz)	[V]	600
	DC	[V]	–

Digital Linear Chargers

Specifications (cont.)

- New 4-color package design

minnkotamotors.com

MINN-KOTA

ON-BOARD MARINE BATTERY CHARGER

DIGITALLY CONTROLLED 2X FASTER CHARGING PROTECTS BATTERIES

Digital CONTROL

MK210D

MK 210D
2 CHARGING BANKS
5 AMPS PER BANK
10 AMPS TOTAL OUTPUT

UL LISTED FC 10 AMPS

CHARGING TECHNOLOGY

CHARGING TECHNOLOGY

DIGITALLY CONTROLLED.
Microprocessor design protects your batteries so you can stay on the water longer. It monitors temperature and state of charge to create a faster, regulated, more precise charge. Also includes automatic shut-off when charging is complete to extend battery life.

DIGITALLY CONTROLLED.
Microprocessor design protects your batteries so you can stay on the water longer. It monitors temperature and state of charge to create a faster, regulated, more precise charge. Also includes automatic shut-off when charging is complete to extend battery life.

ENHANCED STATUS CODES.
Provides comprehensive feedback on charge stage, maintenance mode status, error notification and full charge.

ENHANCED STATUS CODES.
Provides comprehensive feedback on charge stage, maintenance mode status, error notification and full charge.

Digital CONTROL

MULTI-STAGE CHARGING

AMPS & VOLTS

TIME (THREE STAGE CHARGER)

BATTERY CHARGER TEMPERATURE COMPENSATION

BATTERY VOLTAGE

BATTERY TEMPERATURE (degrees F)

MULTI-STAGE CHARGING.
Delivers a fast, precise charge profile by automatically controlling current and voltage without overcharging your batteries.

MULTI-STAGE CHARGING.
Delivers a fast, precise charge profile by automatically controlling current and voltage without overcharging your batteries.

AUTOMATIC TEMPERATURE COMPENSATION.
Adjusts output voltage based on ambient temperature to ensure a full charge and protect your batteries.

AUTOMATIC TEMPERATURE COMPENSATION.
Adjusts output voltage based on ambient temperature to ensure a full charge and protect your batteries.

2010



Digital Linear Chargers

Specifications

- Waterproof, shock-and vibration-resistant aluminum construction
- Saltwater tested and fully corrosion-resistant
- Short circuit, reverse polarity, and ignition protected
- For use with 12V/6 cell batteries that are flooded/wet cell, maintenance free or starved electrolyte (AGM) only
- FCC compliant
- UL listed to marine standard 1236
- 3 year warranty
- Replaces all existing current on-board chargers (excluding portables)
- No Price Increase
- Availability: November 2010



DIGITAL LINEAR ON-BOARD CHARGERS

PRODUCT CODE	PRODUCT DESCRIPTION
1821065	MK 106D (1 bank x 6 amps)
1821105	MK-110D (1 bank x 10 amps)
1822105	MK-210D (2 bank x 5 amps)
1823155	MK-315D (3 bank x 5 amps)
1822205	MK-220D (2 bank x 10 amps)
1823305	MK-330D (3 bank x 10 amps)
1824405	MK-440D (4 bank x 10 amps)
1822305	MK-230D (2 bank x 15 amps)
1823455	MK-345D (3 bank x 15 amps)
1824605	MK-460D (4 bank x 15 amps)

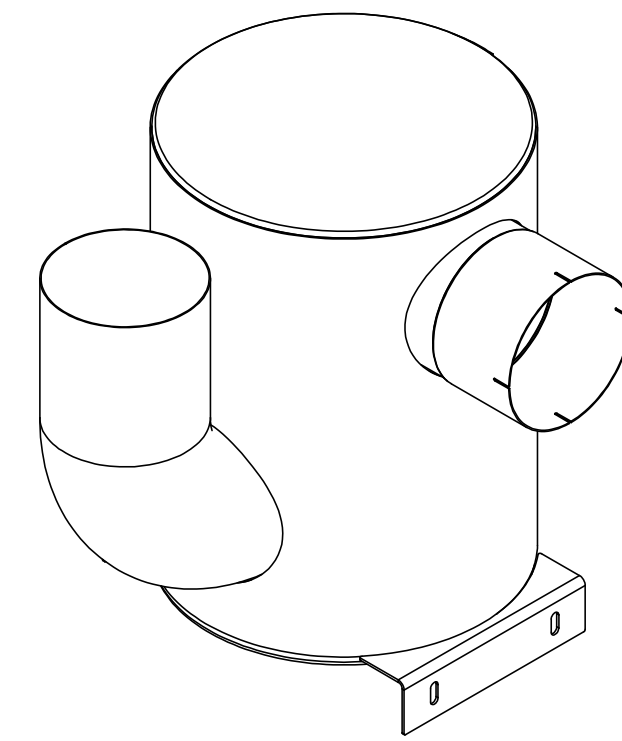
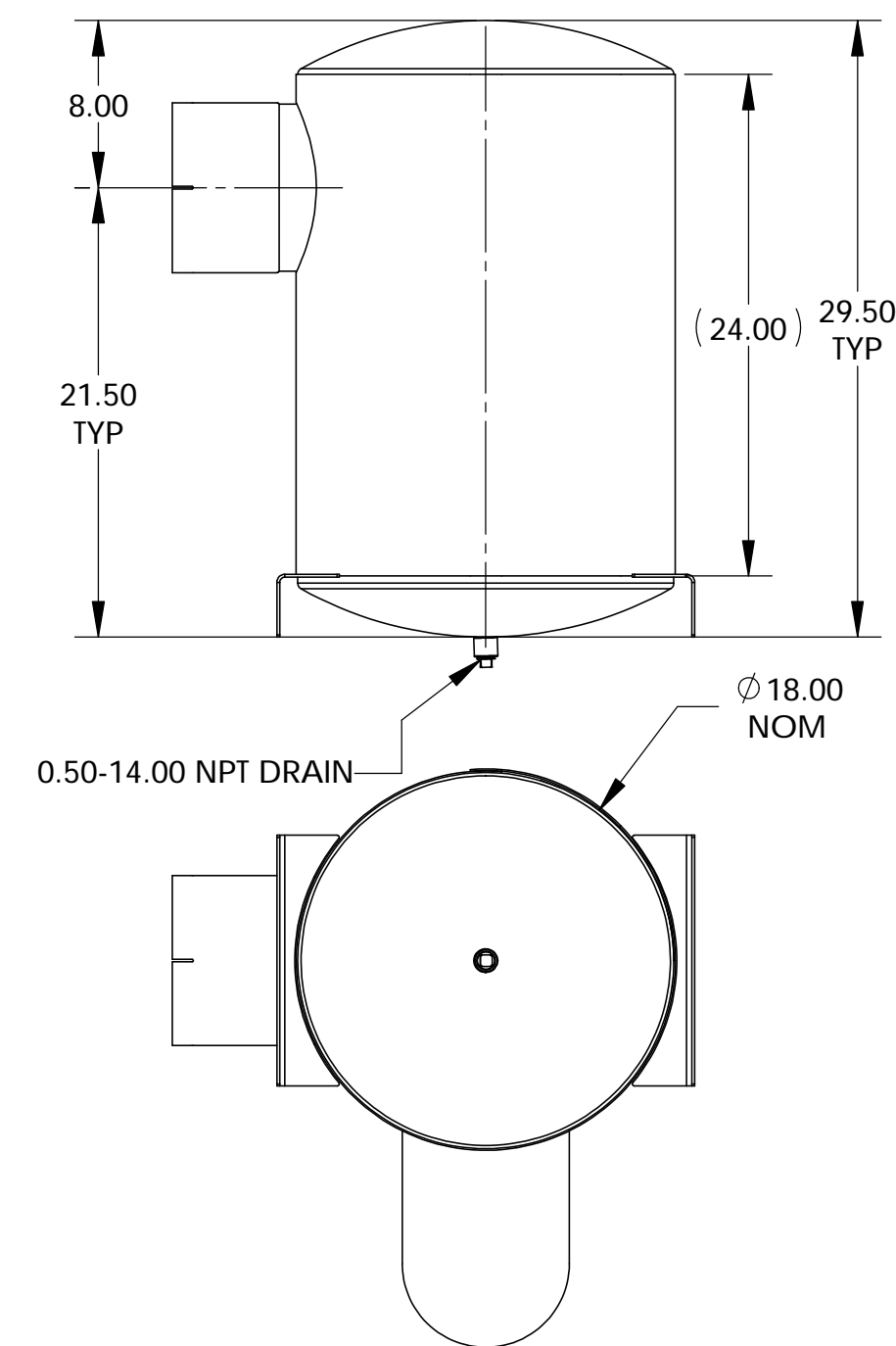
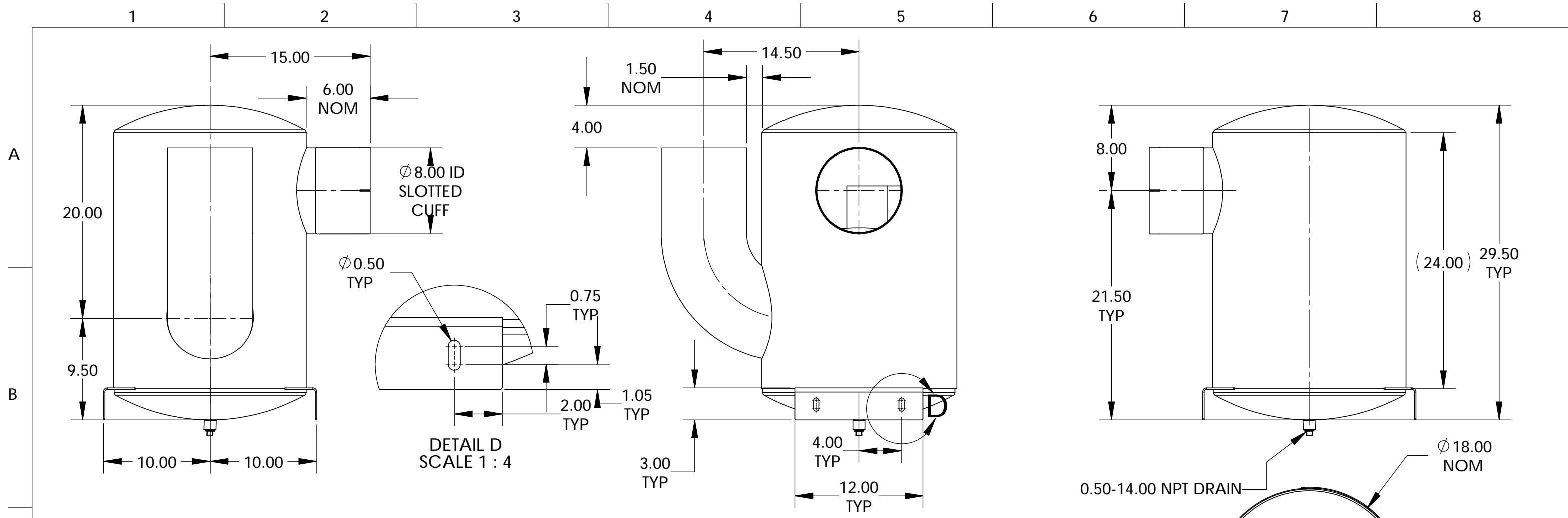

ENGINE INFORMATION	SILENCER INFORMATION	DRAWN BY	DATE	 member of the mandengroup DESCRIPTION SIL: COMP CRIT CS S-E 8.00-8.00 Ø18.00 29.50 OAL F:8.00 --- CONSTRUCTION MATERIAL CS FINISH HIGH TEMP BLACK PAINT PART NUMBER 500-008828 SCALE (DO NOT SCALE) SHEET SIZE 1:9 B
ENGINE MAKE	RESONATOR FREQUENCY	CHECKED BY	DATE	
ENGINE MODEL	RESONATOR ALPHA	ENGINEERING	DATE	
DISPLACEMENT	SILENCER Km	MANUFACTURING	DATE	
EXHAUST FLOW	SILENCER IL	TOLERANCES UNLESS OTHERWISE SPECIFIED	WEIGHT (LBS)	SHEET
EXHAUST TEMPERATURE	TOLERANCES DO NOT APPLY TO GAGE THICKNESS OR COMMERCIAL FEATURES	.X = ±0.25 ALL ANGLES .XX = ±0.125 ±1° .XXX = ±0.0625 .XXXX = ±0.03125	91	
MAX BACK PRESSURE	THIRD ANGLE PROJECTION	This drawing and the information contained is confidential and the property of Bergari Solutions, LLC. None of this information is to be copied or shared in any form without the express permission from Bergari Solutions, LLC.		3 OF 3
RAW SOUND PRESSURE				REV

REV.	BY	DATE	DESCRIPTION	ECO
A	CB	10/25/2017	INITIAL RELEASE	---

CUSTOMER P7/N

SPVD-6000 OPEN DIMENSIONAL OVERVIEW

TOP VIEW

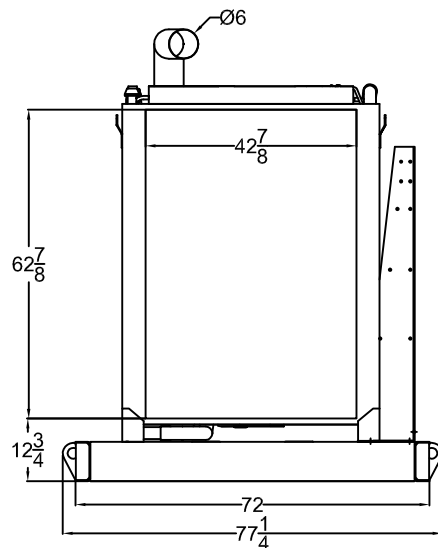
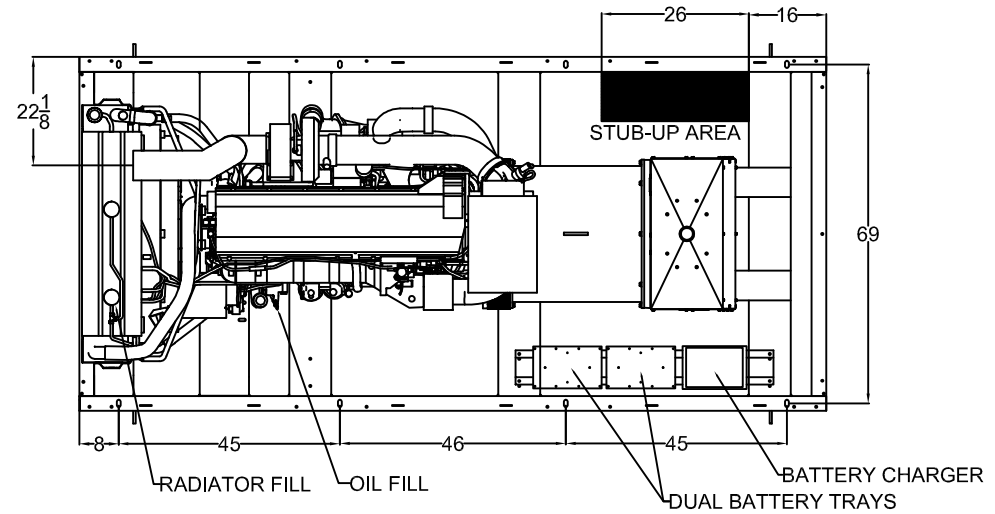

RADIATOR VIEW

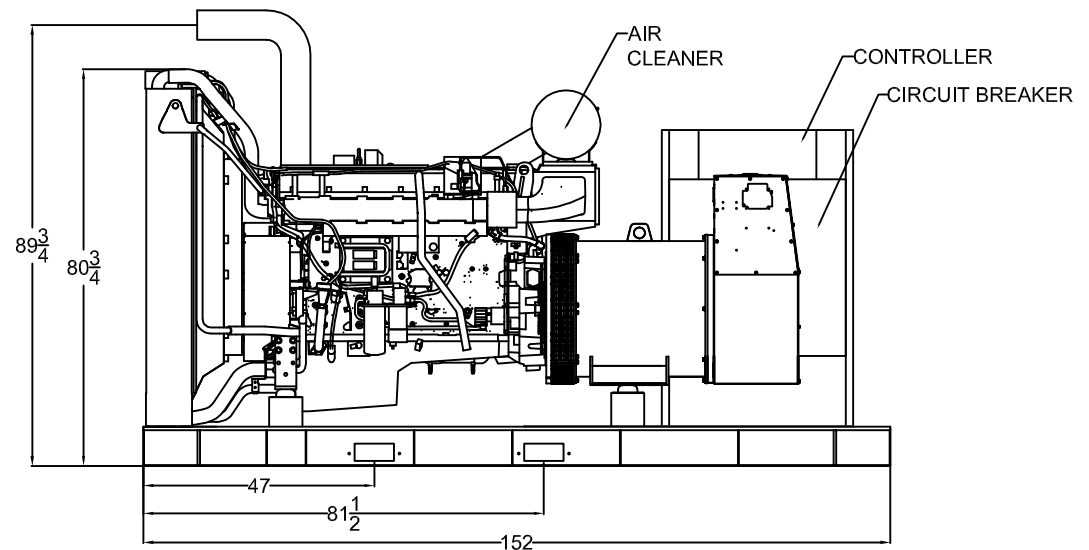

SIDE VIEW

LEVEL 2 ENCLOSURE OUTLINE DIMENSIONS FOR SPVD-5000 THRU SPVD-6000

TOP VIEW

(GEN-SET HAS (6) DOORS, (3) SHOWN OPEN ARE TYPICAL FOR BOTH SIDES)

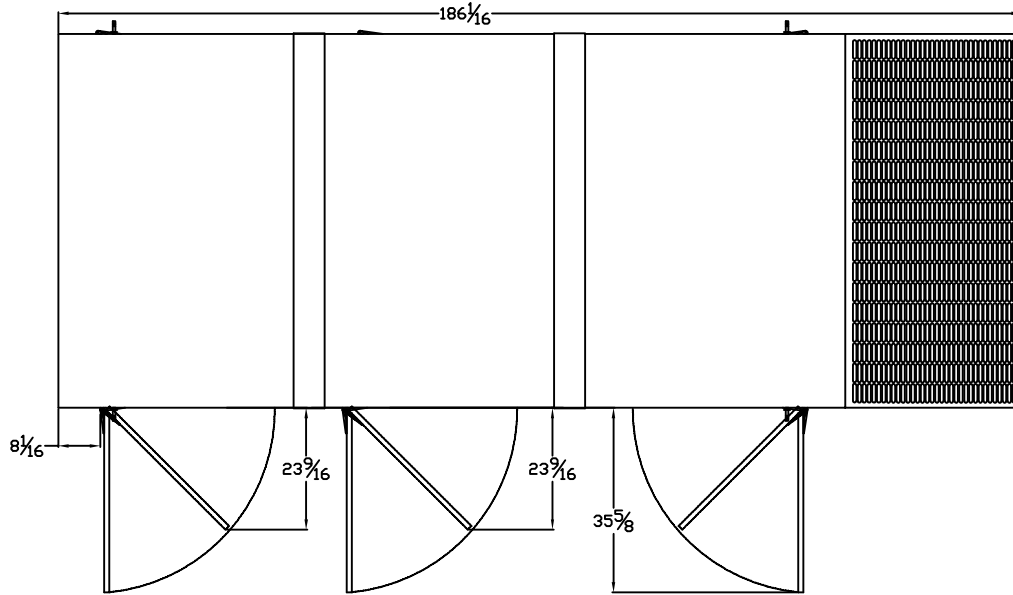

FRAME VIEW

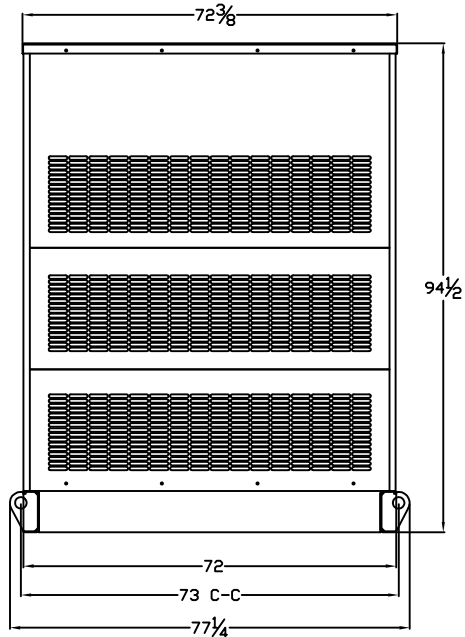
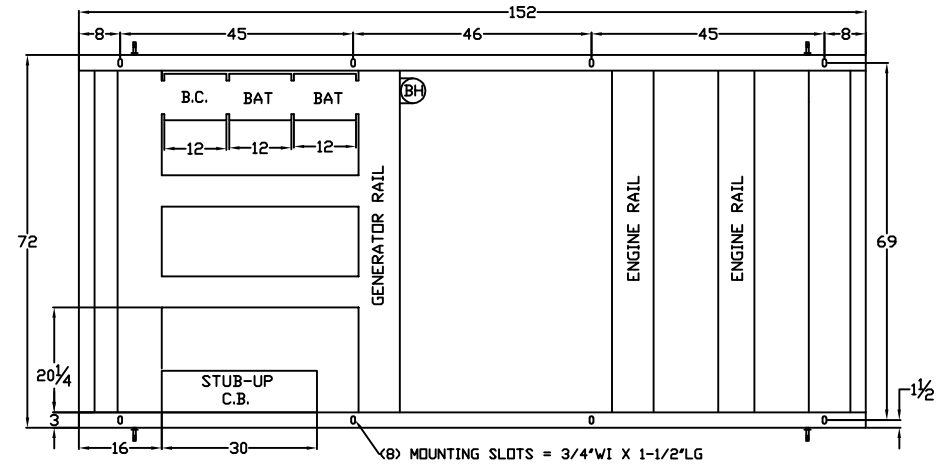

GENERATOR END VIEW

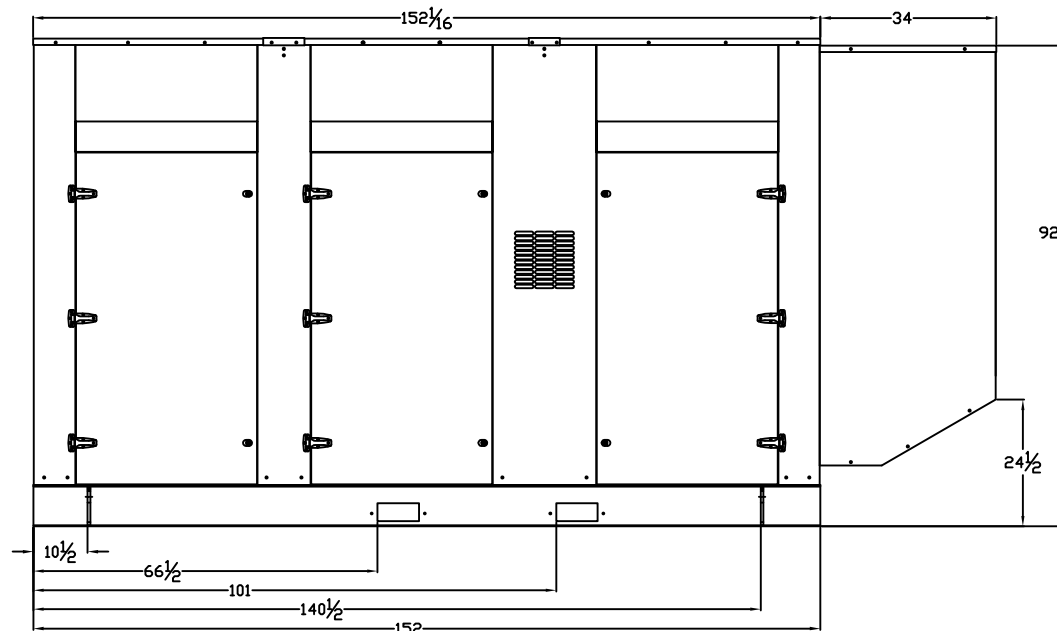

SIDE VIEW

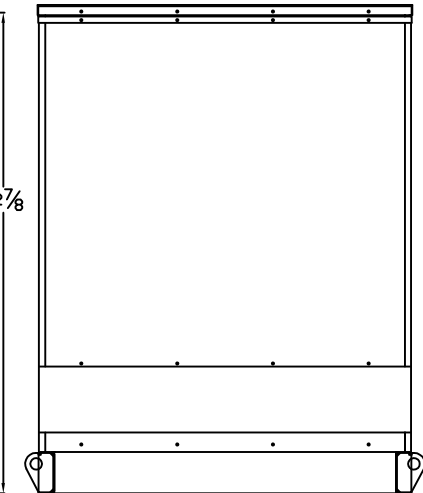

RADIATOR END VIEW