



GILLETTE GENERATORS

LIQUID COOLED DIESEL ENGINE GENERATOR SET

60 HZ MODEL
T4D-4000

| Model | HZ | STANDBY | PRIME |
|--------------------------|----|------------|------------|
| | | 130°C RISE | 105°C RISE |
| T4D-4000-60 HERTZ | 60 | 400 | 400 |



All generator sets are USA prototype built and thoroughly tested. Production models are USA factory built and 100% load tested.



UL1446, UL508, UL142, UL498



NFPA 110, 99, 70, 37

All generator sets meet NFPA-110 Level 1, when equipped with the necessary accessories and installed per NFPA standards.



NEC 700, 701, 702, 708



NEMA ICS10, MG1, ICS6, AB1



ANSI C62.41, 27, 59, 32, 480, 40Q, 81U, 360-05



ASCE 7-05 & 7-10

All generator sets meet 180 MPH rating.



EPA 40CFR Part 60, 89, 1039, 1048, 1054, 1065, 1068

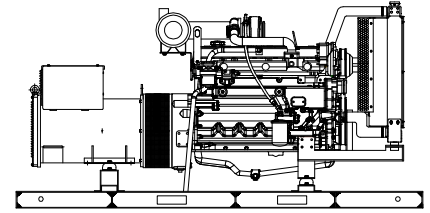

“OPEN” GEN-SET

There is no enclosure, so gen-set must be placed within a weather protected area, uninhabited by humans or animals, with proper ventilation. Silencer not supplied, as installation requirements are not known. However, this item is available as optional equipment.

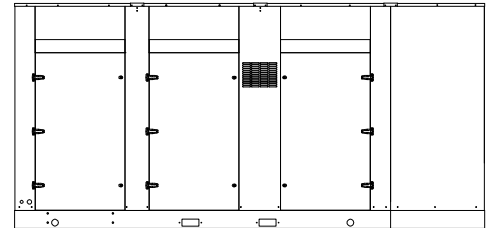

“LEVEL 2” HOUSED GEN-SET

Full aluminum weather protection and superior sound attenuation for specific low noise applications. Critical grade muffler is standard.

GENERATOR RATINGS

| GENERATOR MODEL | VOLTAGE | | PH | HZ | 130°C RISE STANDBY RATING | | 105°C RISE PRIME RATING | |
|----------------------|---------|-----|----|----|---------------------------|------|-------------------------|------|
| | L-N | L-L | | | KW/KVA | AMP | KW/KVA | AMP |
| T4D-4000-3-2 | 120 | 208 | 3 | 60 | 400/500 | 1390 | 400/500 | 1390 |
| T4D-4000-3-3 | 120 | 240 | 3 | 60 | 400/500 | 1200 | 400/500 | 1200 |
| T4D-4000-3-4 | 277 | 480 | 3 | 60 | 400/500 | 600 | 400/500 | 600 |
| T4D-4000-3-5 | 127 | 220 | 3 | 60 | 400/500 | 1314 | 400/500 | 1314 |
| T4D-4000-3-16 | 346 | 600 | 3 | 60 | 400/500 | 481 | 400/500 | 481 |

RATINGS: All single phase gen-sets are dedicated 4 lead windings, rated at unity (1.0) power factor. All three phase gen-sets are 12 lead windings, rated at .8 power factor. 130° C “STANDBY RATINGS” are strictly for gen-sets that are used for back-up emergency power to a failed normal utility power source. This standby rating allows varying loads, with no overload capability, for the entire duration of utility power outage. All gen-set power ratings are based on temperature rise measured by resistance method as defined by MIL-STD 705C and IEEE STD 115, METHOD 6.4.4. All generators have class H (180°C) insulation system on both rotor and stator windings. All factory tests and KW/KVA charts shown above are based 130°C (standby) R/R winding temperature, within a maximum 40°C ambient condition. Generators operated at standby power ratings must not exceed the temperature rise limitation for class H insulation system, as specified in NEMA MG1-22.40. Specifications & ratings are subject to change without prior notice.

APPLICATION & ENGINEERING DATA FOR MODEL T4D-4000-60 HZ

GENERATOR SPECIFICATIONS

Manufacturer..... Stamford Generators
Model & Type..... HCI 534D-311, 4 Pole, 12 Lead, Three Phase
..... HCI534C-311, 4 Pole, 12 Lead, 480V, Three Phase
..... HCI534C-17, 4 Pole, 12 Lead, 600V, Three Phase
Exciter..... Brushless, shunt excited
Voltage Regulator..... Solid State, HZ/Volts
Voltage Regulation..... ½%, No load to full load
Frequency..... 60 HZ
Frequency Regulation..... ± ½% (1/2 cycle, no load to full load)
Unbalanced Load Capability..... 100% of standby amps
One Step Load Acceptance..... 100% of nameplate rating
Total Stator and Load Insulation..... Class H, 180°C
Temperature Rise..... 105°C R/R, prime rating @ 40°C amb.
3 Ø Motor Starting @ 30% Voltage Dip (208-240V)..... 980 kVA
3 Ø Motor Starting @ 30% Voltage Dip (480V-600V) 1280 kVA
Bearing..... 1, Pre-lubed and sealed
Coupling..... Direct flexible disc.
Total Harmonic Distortion..... Max 3½% (MIL-STD705B)
Telephone Interference Factor..... Max 50 (NEMA MG1-22)
Deviation Factor..... Max 5% (MIL-STD 405B)
Alternator..... Self ventilating and drip-proof
Ltd. Warranty Period..... 24 Months from start-up date or
..... 1000 hours use, first to occur.

GENERATOR FEATURES

- World Renown Stamford Electric Generator having UL-1446 certification.
- Full generator protection with **Basler DGC-2020** controller, having UL-508 certification.
- Automatic voltage regulator with over-excitation, under-frequency compensation, under-speed protection, and EMI filtering. Entire solid-state board is encapsulated for moisture protection.
- Generator power ratings are based on temperature rise, measured by resistance method, as defined in MIL-STD 705C and IEEE STD 115, Method 6.4.4.
- Power ratings will not exceed temperature rise limitation for class H insulation as per NEMA MG1-22.40.
- Insulation resistance to ground, exceeds 1.5 meg-ohm.
- Stator receives 2000 V. hi-potential test on main windings, and rotor windings receive a 1500 V. hi-potential test, as per MIL-STD 705B.
- Full amortisseur windings with UL-1446 certification.
- Complete engine-generator torsional acceptance, confirmed during initial prototype testing.
- Full load testing on all engine-generator sets, before shipping.

ENGINE SPECIFICATIONS AND APPLICATIONS DATA

ENGINE

Manufacturer..... VOLVO-PENTA
Model and Type..... TAD1672VE, 4 cycle, liquid Cooled
Aspiration..... Turbo After Cooler, Air to Air
Charged Air Cooled System..... Air to Air
Cylinder Arrangement..... 6 Cylinders, In-Line
Displacement Cu. In. (Liters)..... 984 (16.1)
Bore & Stroke in (Cm)..... 5.67 x 6.50 (14.4 x 16.5)
Compression Ratio..... 17.0:1
Main Bearings..... Tin Overlay with Babbit Backing
Cylinder Head..... Cast Iron with overhead Cam
Pistons..... Aluminum Alloy with Graphite Coating
Crankshaft..... Induction Hardened, Heat Treated Forged
Valves..... Heat Treated and Hardened Exhaust Valve
Governor..... Electronic, EMS 2.2
Frequency Regulation..... ± 1/4%
Air Cleaner..... Dry, Replaceable Cartridge
Engine Speed..... 1800 rpm
Max Power, bhp (kwm) Standby..... 700 (515)
BMEP: psi (MPa) Standby..... 309 (2.13)
Ltd. Warranty Period..... 2 Year or 1000 hrs, first to occur

FUEL SYSTEM

Type..... Diesel Fuel Oil (ASTM No. 2-D)
Combustion System..... Direct Injection
Fuel Injection Pump..... Electronic, Delphi E3
24 VDC Coolant heaters..... Optional Equipment
Fuel Filter..... Yes with Water Separator

FUEL CONSUMPTION

| GAL/HR (LITER/HR) | STANDBY | PRIME |
|-------------------|--------------|--------------|
| 100% LOAD | 32.0 (121.0) | 32.0 (121.0) |
| 75% LOAD | 25.6 (96.9) | 25.6 (96.9) |
| 50% LOAD | 20.8 (78.7) | 20.8 (78.7) |

OIL SYSTEM

Type..... Full Pressure
Oil Pan Capacity qt. (L)..... 50.7 (48)
Oil Pan Cap. W/ filter qt. (L)..... 44.3 (42)
Oil Filter..... 3, Replaceable Cartridge type

ELECTRICAL SYSTEM

Ignition System..... Electronic
Eng. Alternator/Starter: 24 VDC, negative ground, 110 amp/hr.
Recommended battery to -18°C (0° F):(2) 12 VDC, BCI# 31,
Max. Dimensions: 14”lg x 6 ¾” wi x 10” hi, with standard
round posts. Min output 1000 CCA. Battery tray (max. dim. at
15”lg x 7”wi). This model has (2) battery trays, (2) hold down
straps, (2) sets of battery cables, and (1) battery charger.
Installation of (2) 12VDC starting batteries connected in series
for 24VDC output is required, with possible higher AMP/HR
rating, as described above, if the normal environment
temperature averages -13° F (-25°C) or cooler.

CERTIFICATIONS

All engines are EPA emissions certified. All non-emergency stationary diesel engines are Tier IV Final compliant.

APPLICATION & ENGINEERING DATA FOR MODEL T4D-4000-60 HZ

COOLING SYSTEM

Type of System Air to Air, Charged Air Cooler
 Coolant PumpPre-lubricated, self-sealing
 Cooling Fan TypePusher
 Fan Diameter inches (cm).....35.1 (89)
 Fan drive ratio..... 1.04:1
 Ambient Capacity of Radiator °F (°C)..... 131 (55)
 Engine Jacket Coolant Capacity gal. (L).....8.70 (33)
 Radiator Coolant Capacity gal. (L) 16.0 (60)
 Water Pump Capacity gpm (L/min)..... 122 (462)
 Heat Reject Coolant: Btu/min12,113
 Air to Air Heat Reject, BTU/min.6,028
 Heat Radiated to Ambient, BTU/min3,415
 Low Radiator Coolant Level Shutdown.....Standard
 Note: Coolant temp. shut-down switch setting at 228°F (109°C) with 50/50 (water/antifreeze) mix.

COOLING AIR REQUIREMENTS

Combustion Air cfm (m³/min) 1,324 (37.5)
 Max Air Intake Restrictions:
 Clean Air Cleaner, KPA (psi) 5 (1.5)
 Radiator Cooling Air, SCFM (m³/min).....18,180 (514)

EXHAUST SYSTEM

Exhaust Outlet Size.....8"
 Max. Back Pressure in KPA (in. H2O).....4 (16)
 Exhaust Flow, at rated KW, CFM (m³/min)..... 3,461 (98)
 Exhaust Temp, (Stack) °F (°C)932 (500)

SOUND LEVELS MEASURED IN dB(A)

| | Open Set | Level 2 Encl. |
|---|-------------|------------------|
| Level 2, SCR/Residential Silencer | 98 | 83 |

Note: Open sets (no enclosure) have installed selective catalytic reduction/residential silencer system. Level 2 enclosure has installed selective catalytic reduction/residential silencer. Sound tests are averaged from several test points and taken at 23 ft. (7 m) from source of noise at normal operation.

DERATE GENERATOR FOR ALTITUDE

3% per 1000 ft. (305m) above 3000 ft. (914m) from sea level

DERATE GENERATOR FOR TEMPERATURE

2% per 10°F (5.6°C) above 104°F (40°C)

DIMENSIONS AND WEIGHTS

| | Open Set | Level 2 Enclosure |
|--------------------------------|--------------|----------------------|
| Length in (cm)..... | 152 (368) | 200 (508) |
| Width in (cm)..... | 72 (183) | 72 (183) |
| Height in (cm)..... | 107 (272) | 94 (239) |
| 3 Ø Net Weight lbs (kg)..... | 9625 (4366) | 12125 (5500) |
| 3 Ø Ship Weight lbs (kg) | 10025 (4547) | 12525 (5681) |

BASLER DGC-2020 DIGITAL MICROPROCESSOR CONTROLLER

Basler DGC-2020



The “2020” controller is a highly advanced integrated gen-set control system for single gen-set applications. This controller includes a backlit LCD display which continuously displays the status of the engine and generator at all times.

Basler “DGC-2020” includes: Generator metering (including three phase) • Engine – Generator protections including IEEE-[27] under voltage, [32] power, [40] loss of excitation, [59] over voltage, [81] over and under frequency, Exercise timer • SAE J1939 engine ECU communications • Expansion capabilities for both inputs and outputs with expansion • Remote communications through RS-485 to Basler’s RDP110 remote Display panel • (16) programmable contact inputs • (15) programmable contact outputs- (3) for up to 30AmpDC and (12) for up to 2 Amp DC • Illuminated Text Display • Front panel menu scroll buttons • Front panel operation mode buttons for STOP, RUN and AUTO • Alarm Silence and Lamp Test buttons

This controller includes expansion features including, RS485 (using MODBUS), direct USB connection with PC, expansion optioned using BESTCOMSPPlus for remote annunciation and remote relay interfacing for a distance of up to 3300FT. The controller software is freely downloadable from the internet and allows monitoring with direct USB cable, LAN, or by internet via the built in web interface.



Further expansion is available by adding the optional RDP-110 remote display panel module. This featured device will allow Four programmable LEDs (2) alarms and (2) pre-alarms • (17) alarms and pre-alarms displayed from Basler controller • audible alarm horn • lamp test and alarm silence buttons • RD100 local power supply inputs of either 12vdc or 24vdc • connects through Basler controller through RS-485 communications protocol • conduit box included for (2) mounting configurations- either surface mount or semi-flush mounting.

STANDARD FEATURES FOR MODEL T4D-4000-60 HZ

STANDARD FEATURES

CONTROL PANEL:

- Basler DGC-2020 digital microprocessor with logic allows programming in the field. Controller has:
- STOP-MANUAL-AUTO modes and automatic engine shutdowns, signaled by full text LCD indicators:
 - Low oil pressure
 - High engine temp
 - Low Radiator Level
 - Three auxiliary alarms
 - Battery fail alarm
 - Engine fail to start
 - Engine over speed
 - Engine under speed
 - Over & under voltage

Also included is tamper-proof engine hour meter

ENGINE:

- Fuel filter
- Full flow Oil filter
- Air filter
- Fuel pump
- Oil pump
- Solenoid type starter motor
- Hi-temp radiator
- Jacket water pump
- Thermostat
- Pusher fan and guard
- Exhaust manifold
- Electronic Governor
- 24 VDC battery charging alternator
- Flexible fuel and exhaust connectors
- Vibration isolators
- Open coolant recovery system with 50/50 water to anti-freeze mixture
- flexible oil & radiator hose
- Shut-down sensors for low oil pressure, high coolant temp., low coolant level, high ambient temp.

AC GENERATOR SYSTEM:

- AC generator
- Shunt excited
- Brushless design
- Circuit Breaker installed and wired to gen-set
- Direct connection to engine with flex disc
- Class H, 180°C insulation
- Self ventilated
- Drip proof construction
- UL Certified

VOLTAGE REGULATOR:

- 1% Voltage regulation
- EMI filter
- Under-speed protection
- Over-excitation protection
- total encapsulation

DC ELECTRICAL SYSTEM:

- Battery trays
- Battery cables
- Battery hold down straps
- 3-stage battery charger with float, absorption, & bulk automatic charge stages

WEATHER / SOUNDPROOF ALUMINUM HOUSING:

Corrosion Resistant Protection consisting of:

- (9) Heated and Agitated Wash Stages
- Zinc Phosphate Etching-Coating Stage
- Final Baked on Enamel Powder Coat
- 18/8 Stainless Steel Hardware

Design & specifications subject to change without prior notice. Dimensions shown are approximate. Contact Gillette for certified drawings. DO NOT USE DIMENSIONS FOR INSTALLATION PURPOSES.

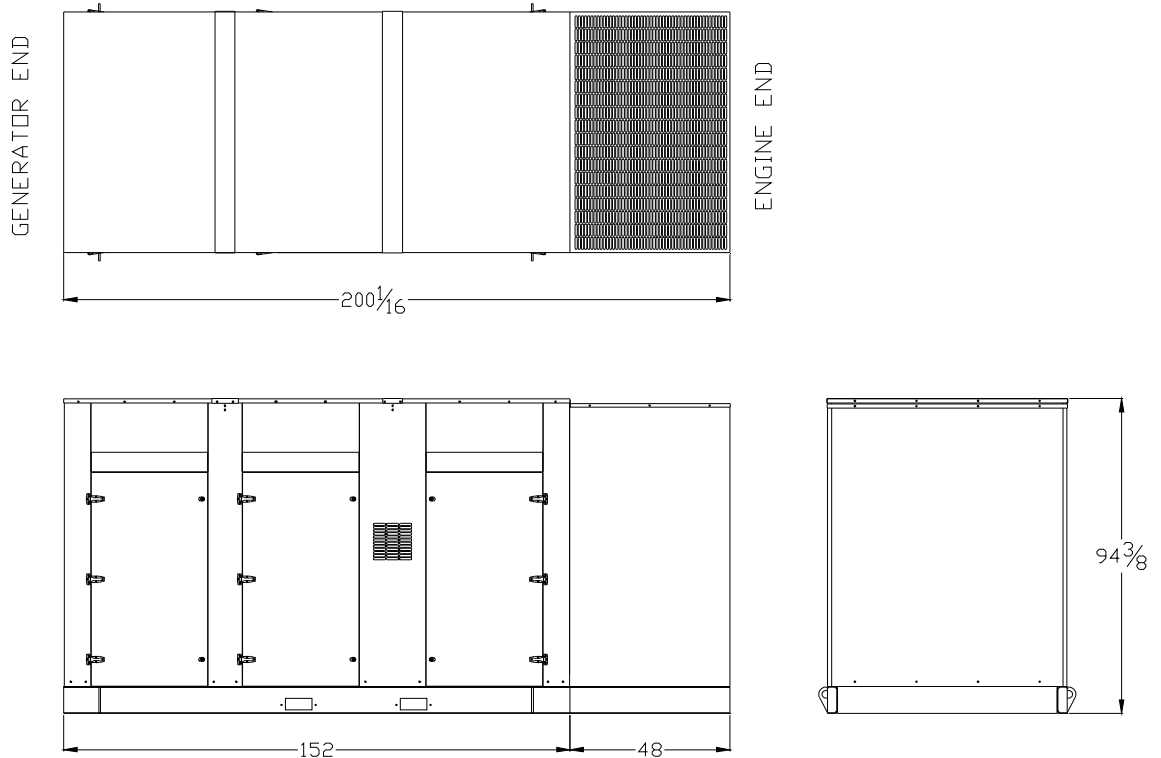

TAD1670-1672VE

16 litre, in-line 6 cylinder - 405, 450 & 515 kW

EU Stage IV / US EPA Tier 4 Final

TAD1670-1672VE is a powerful, reliable and economical off-road Diesel Engine range built on the Volvo in-line six concept.

Low cost of ownership

World class fuel efficiency combined with a reliable exhaust aftertreatment system gives high uptime as well as low cost of ownership. No downtime for regeneration or decreased service intervals.

Compact & simple installation

SCR technology selected by Volvo does not increase amount of cooling capacity needed. As optional equipment all material needed in order to install the engine can be ordered from Volvo Penta. Installation guidelines as well as drawings and CAD models are easy to access. The result is an engine and aftertreatment system that is easy to install with minor impact on existing machine layout.

Durability & low noise

Long experience with SCR systems in combination with base engine development reduces risk of downtime. Well-balanced to produce smooth operation with low noise.

Power & torque

Maximum power and torque available at low rpm. As a result noise as well as fuel consumption is very low. Useful engine speed for the TAD1670-1672VE is due to power and torque layout very flexible

Low exhaust emission

Efficient injection as well as robust engine design in combination with optimised SCR technology and a light EGR contributes to excellent combustion and low fuel consumption.

Easy service & maintenance

Easily accessible service and maintenance points contribute to the ease of service of the engine. As optional equipment possible to remote mount filters and service points.



- Proven and straight-forward design - built on Volvo Group technology
- Low cost of ownership and operation
- High power and torque already at low engine speed
- SCR and light EGR only - no DPF, DOC or regeneration
- Compact, simple installation and easy to service
- Similar engine footprint for all emission standards
- Wide range of optional equipment

Technical description

Engine and block

- Cast iron cylinder block
- Wet, replaceable cylinder liners
- Replaceable valve guides and valve seats
- Overhead camshaft and four valves per cylinder

Lubrication system

- Full flow disposable spin-on oil filter, for extra high filtration
- Gear type lubricating oil pump, gear driven by the transmission
- Oil level sensor at startup

Fuel system

- Electronic high pressure unit injectors
- Fuel prefilter with water separator and water-in-fuel indicator / alarm
- Gear driven low-pressure fuel pump
- Fine fuel filter with manual feed pump and fuel pressure switch

Cooling system

- Available as Power pack or base engine.
- Belt driven coolant pump with high degree of efficiency

Turbo charger

- Electronically controlled Waste-gate

Electrical system

- Engine Management System 2 (EMS 2.3), an electronically controlled processing system which optimizes engine performance.
- The instruments and controls connect to the engine via the CAN SAE J1939 interface. Options available for engine control equipment.

Exhaust aftertreatment system

- SCR and light EGR only
- Airless urea injection
- Wide range of options available, including different sized AdBlue® / DEF tanks (also possible for OEM to design own tank).

**VOLVO
PENTA**

TAD1670-1672VE

Technical Data

General

| | |
|---|----------------|
| Engine designation | TAD1670-1672VE |
| No. of cylinders and configuration..... | in-line 6 |
| Method of operation | 4-stroke |
| Bore, mm (in.)..... | 144 (5.67) |
| Stroke, mm (in.)..... | 165 (6.50) |
| Displacement, l (in ³)..... | 16.12 (984) |
| Dry weight, engine only, kg (lb)..... | 1322 (2915) |

| Engine | kW | Hp | rpm | Max Nm |
|-----------|-----|------|------|--------|
| TAD1670VE | 405 | 551 | 1900 | 2750 |
| TAD1671VE | 450 | 612 | 1900 | 2900 |
| TAD1672VE | 515 | 1800 | 3200 | |

Main components - principal layout

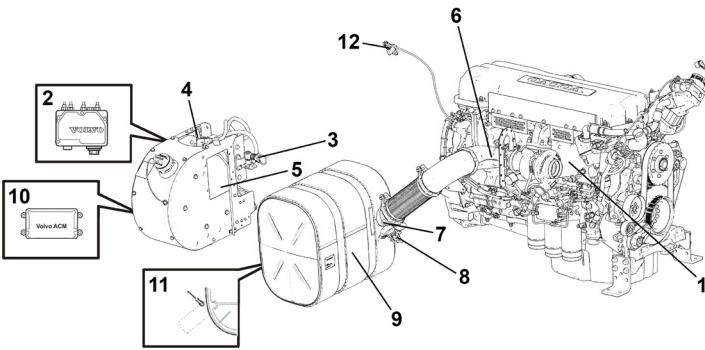

- | | |
|------------------------------------|-------------------------------------|
| 1. Engine | 7. Temperature sensor exhaust |
| 2. Pump unit | 8. Dosage Valve |
| 3. Solenoid valve, heating/cooling | 9. Muffler with catalytic converter |
| 4. AdBlue / DEF level sensor | 10. Aftertreatment control module |
| 5. AdBlue / DEF solution tank | 11. NOx sensor |
| 6. NOx sensor | 12. Temperature sensor air |

Dimensions

Not for installation. Dimensions in mm.

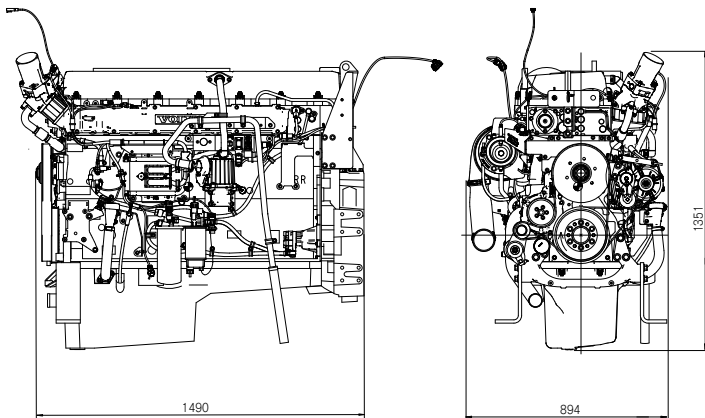

Power, kW

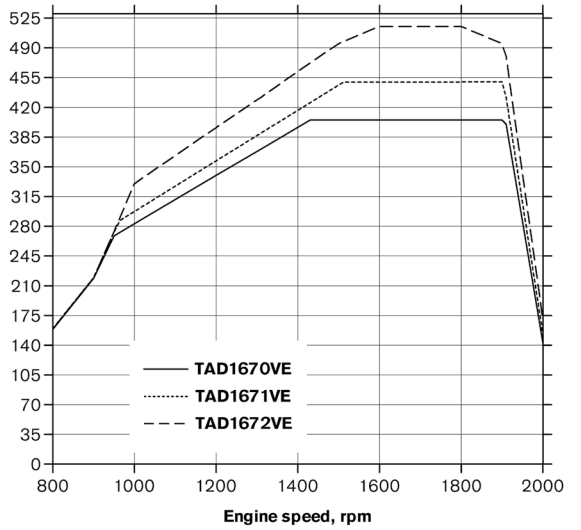

Torque, Nm

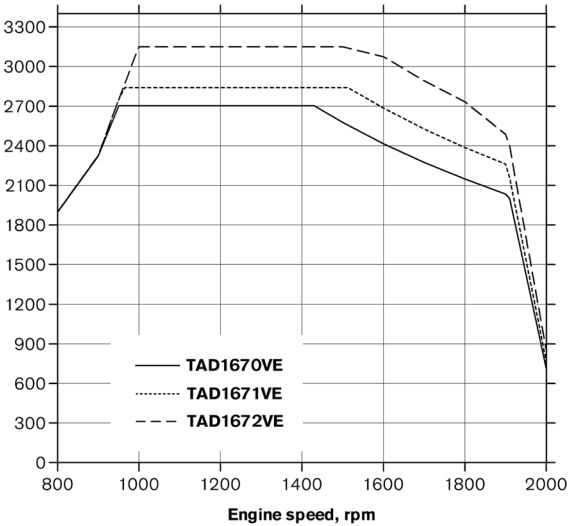

Fuel consumption, g/kWh

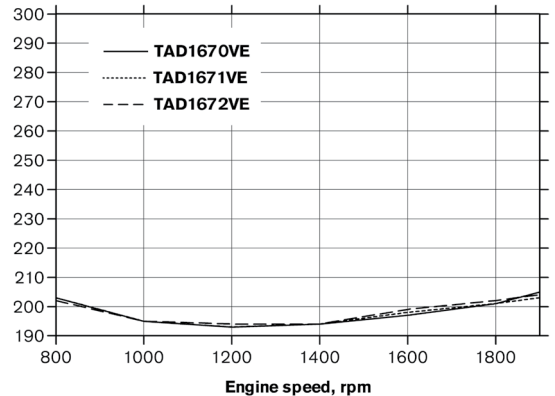

Power standards

The engine performance corresponds to ISO 3046, BS 5514 and DIN 6271. The technical data applies to an engine without cooling fan and operating on a fuel with calorific value of 42.7 MJ/kg (18360 BTU/lb) and a density of 0.84 kg/litre (7.01 lb/US gal, 8.42 lb/Imp gal), also where this involves a deviation from the standards.

Additional information

For additional information, please contact your Volvo Penta representative or visit www.volvopenta.com.

VOLVO PENTA

AB Volvo Penta

SE-405 08 Göteborg, Sweden
www.volvopenta.com

Not all models, standard equipment and accessories are available in all countries. All specifications are subject to change without notice. The engine illustrated may not be entirely identical to production standard engines.

® = Registered trademark of the Verband der Automobilindustrie e.V. (VDA).

Important

This Technical Data Sheet and the corresponding Installation Instructions provide important information to ensure the installed engine will operate according to the design specification in the Volvo Penta application for certification.

Requirements marked with  are considered as critical for exhaust emissions compliance according to the design specification in the Volvo Penta application for certification.

Failing to follow and meet these instructions and requirements when installing a certified engine in a piece of nonroad equipment for use in the United States violates U.S. federal law (40 CFR 1068.105(b)), subject to fines or other penalties as described in the Clean Air Act.

General

In-line four stroke diesel engine with direct injection. Rotation direction, counterclockwise viewed towards flywheel

| | | | |
|---------------------|---|-----------------|-------------|
| Number of cylinders | | | 6 |
| Displacement, total | | liters | 16,12 |
| | | in ³ | 984 |
| Firing order | | | 1-5-3-6-2-4 |
| Bore | | mm | 144 |
| | | in | 5,67 |
| Stroke | | mm | 165 |
| | | in | 6,50 |
| Compression ratio | | | 17,0:1 |
| Wet weight | Engine only (Estimated) (excl after treatment comp.) | kg | 1395 |
| | | lb | 3075 |
| | Power pac | kg | |
| | | lb | |

Performance

| | | | | rpm | 1200 | 1500 | 1800 | 1900 |
|--|--------|-------------|----------|------------------|-------------|-------------|-------------|-------------|
| IFN Power | 515 kW | without fan | | kW | 396 | 495 | 515 | 495 |
| | | | | hp | 538 | 673 | 700 | 673 |
| | | with fan | 890 mm | kW | 389 | 481 | 492 | 468 |
| | | | | hp | 529 | 654 | 669 | 636 |
| Torque at: | | IFN Power | | Nm | 3150 | 3150 | 2732 | 2488 |
| | | | | lbf ft | 2323 | 2323 | 2015 | 1835 |
| Max torque at engine speed | | rpm | 1260 rpm | Nm | 3200 | | | |
| | | | | lbf ft | 2360 | | | |
| Power tolerance | | | | % | ±2 | | | |
| Mean piston speed | | | | m/s | 6,6 | 8,3 | 9,9 | 10,5 |
| | | | | ft/sec | 21,7 | 27,1 | 32,5 | 34,3 |
| Effective mean pressure at: | | IFN Power | | MPa | 2,45 | 2,46 | 2,13 | 1,94 |
| | | | | psi | 356 | 356 | 309 | 281 |
| Max combustion pressure at: | | IFN Power | | MPa | 19 | 20 | 20 | 19 |
| | | | | psi | 2755 | 2900 | 2900 | 2755 |
| Total mass moment of inertia, J (mR ²) (not including flywheel) | | | | kgm ² | 4,1 | | | |
| | | | | lbf ² | 97,3 | | | |
| Friction Power | | | | kW | 26 | 39 | 58 | 65 |
| | | | | hp | 35 | 53 | 79 | 88 |

Derating see Technical Diagrams

Engine brake performance (only engines with VCB)

| | | rpm | 1200 | 1500 | 1900 | 2200 |
|---|-------------|--------|-----------|------|------|------|
| Brake power: | without fan | kW | 85 | 152 | 284 | 345 |
| | | hp | 116 | 207 | 386 | 469 |
| Brake torque: | without fan | Nm | 676 | 968 | 1427 | 1498 |
| | | lbf ft | 499 | 714 | 1053 | 1104 |
| Engine speed range for VCB activation: | | rpm | 1000-2200 | | | |
| Min engine speed with VCB still active: | | rpm | 900 | | | |
| Min oil temperature for VCB activation: | | °C | 55 | | | |

Cold start performance

| | | | | | |
|-------------------------------|---|----------|---------------|---------------------------------|--|
| *Cold start limit temperature | without starting aid | °C | -10 | | |
| | | °F | 14 | | |
| | with manifold heater 2 kW | °C | -25 | | |
| | | °F | -13 | | |
| | with manifold heater 2 kW and block heater | °C | -30 | | |
| | | °F | -22 | | |
| *Specify oil and fuel quality | T>-15°C Oil VDS4/VDS3 15W/40 T<-15°C Oil VDS4/VDS3 5W/40 | | | | |
| Block heater type | Make | Power kW | Engaged hours | Cooling water temp engine block | |
| Self circulating | Volvo 21578298 | 2 | 12 | 1°C 34°F | |

* See also general section in the sales guide

Lubrication system

| | | | |
|--|------------|----------|-------------------|
| Lubricating oil consumption at max rpm at: | IFN Power | liter/h | 0,03 |
| | | US gal/h | 0,008 |
| Oil system capacity including filters | | liter | 48 |
| | | US gal | 12,68 |
| Oil sump capacity: (both variants) | Max | liter | 42 |
| | | US gal | 11,10 |
| | Min | liter | 32 |
| | | US gal | 8,45 |
| Oil change intervals/specifications | VDS3 | h | 1000 / See manual |
| | VDS4 | h | 1000 / See manual |
| Engine angularity limits: | front up | ° | 30 |
| | front down | ° | 30 |
| | side tilt | ° | 30 |
| Oil pressure at rated speed | | kPa | 300 - 650 |
| | | psi | 44 - 94 |
| Oil pressure shut down switch setting | | kPa | N/A |
| | | psi | |



Lubrication system

| | | | |
|--------------------------------------|-----|----|-----|
| Lubrication oil temperature in sump: | max | °C | 130 |
| | | °F | 266 |
| Oil filter micron size | | μ | 40 |



Fuel system

| | | |
|--|--|-------------|
| System supply flow at max. Speed | liter/h US gal/h | 165 43,6 |
| Fuel supply line max. restriction (measured at fuel inlet connection) | kPa psi | 10 1,5 |
| Fuel supply line max. pressure, during engine stand still (measured at fuel inlet connection) | kPa psi | |
| System return flow at max. Speed | liter/h US gal/h | 30,0 7,9 |
| Fuel return line max. restriction (measured at fuel return connection) | kPa psi | 20 2,9 |
| Max. allowable inlet fuel temp (Measured at fuel inlet connection) | °C °F | 60 140 |
| Prefilter / Water separator micron size | μ | 10 |
| Fuel filter micron size | μ | 5 |
| Engine Control System, standard | Volvo/EMS2.3 | |
| Specific UREA consumption, NRTC | Vol% | 5,9 |
| Fuel to conform to | Fuel equal to or better than EN590:2009 or ASTM D975-09 and Max sulphur 15ppm | |

Intake and exhaust system

| | | rpm | 1200 | 1500 | 1800 | 1900 |
|--|-----------|---------------|--------------|--------------|--------------|--------------|
| Change air consumption at: (+25°C and 100kPa) | IFN Power | m³/min cfm | 27,2 961 | 34,5 1218 | 37,5 1324 | 37 1307 |
|  See front page for important information | | | | | | |
| Max allowable air intake restriction including piping | | kPa psi | 6 0,9 | | | |
| Heat rejection to exhaust at: | IFN Power | kW BTU/min | 278 15810 | 358 20359 | 402 22861 | 392 22293 |
| Exhaust gas temperature after turbine at: | IFN Power | °C °F | 455 851 | 480 896 | 500 932 | 500 932 |
|  See front page for important information | | | | | | |
| Max allowable back pressure in exhaust line (after turbine) Pipe dimension Ø: 125 mm | | kPa psi | 23 3,3 | 30 4,4 | 34 4,9 | 35 5,1 |
|  See front page for important information | | | | | | |
| Max allowable temperature drop between turbine and SCR muffler inlet. | | Δ°C Δ°F | 10 18 | 10 18 | 10 18 | 10 18 |
| SCR muffler pressure drop (at exhaust gas flow and exhaust temp given) | | kPa psi | 20 2,9 | 25 3,6 | 30 4,4 | 31 4,5 |
| Exhaust gas flow at: (temp and pressure after turbine at the corresponding power setting) | IFN Power | m³/min cfm | 68,5 2419 | 90,0 3178 | 98 3461 | 95 3355 |

| Cooling system | | rpm | 1200 | 1500 | 1800 | 1900 |
|--|---|---|-------------|-------------|-------------|-------------|
| Heat rejection radiation from engine at: | IFN Power | kW | 8 | 9 | 10 | 10 |
| | | BTU/min | 455 | 512 | 569 | 569 |
| Heat rejection to coolant at: | IFN Power | kW | 156 | 187 | 213 | 212 |
| | | BTU/min | 8872 | 10635 | 12113 | 12056 |
| Coolant | | Volvo Penta coolant "ready mix" or Volvo Penta coolant mixed with clean fresh water 40 / 60 | | | | |
| Radiator cooling system type | | Closed circuit | | | | |
| Standard radiator core area | IFN Power | m ² | 1,31 | | | |
| | | foot ² | 14,10 | | | |
| Fan diameter | 890 mm IFN Power | mm | 890 | | | |
| | | in | 35,04 | | | |
| Fan power consumption | 890 mm | kW | 3,5 | 6,8 | 11,7 | 13,5 |
| | | hp | 5 | 9 | 16 | 18 |
| Fan drive ratio | fan Ø890 | 0,88 | | | | |
| Coolant capacity: | engine | liter | 33 | | | |
| | | US gal | 8,7 | | | |
| | std. 1,31m ² radiator with hoses | liter | 60 | | | |
| | | US gal | 15,9 | | | |
| Coolant pump | | drive/ratio | belt/1,77:1 | | | |
| Coolant flow with standard system | | l/s | 4,7 | 5,8 | 7 | 7,3 |
| | | US gal/s | 1,2 | 1,5 | 1,8 | 1,9 |
| Minimum coolant flow | | l/s | 4,3 | 5,4 | 6,6 | 6,9 |
| | | US gal/s | 1,1 | 1,4 | 1,7 | 1,8 |
| Maximum outer circuit restriction incl. piping | | kPa | 70,0 | | | |
| | | psi | 10,2 | | | |
| Thermostat: | start to open | °C | 82 | | | |
| | | °F | 180 | | | |
| | fully open | °C | 92 | | | |
| | | °F | 198 | | | |
| Maximum static pressure head (expansion tank height + pressure cap setting) | | kPa | 100 | | | |
| | | psi | 14,5 | | | |
| Minimum static pressure head (expansion tank height + pressure cap setting) | | kPa | 70 | | | |
| | | psi | 10,2 | | | |
| Standard pressure cap setting | | kPa | 75 | | | |
| | | psi | 10,9 | | | |
| Maximum top tank temperature | | °C | 107 | | | |
| | | °F | 225 | | | |
| Recommended Draw down capacity. The difference between min coolant level in the expansion tank and the lowest level where the engine's coolant system still are functioning | | liter | 2 | | | |
| | | US gal | 0,5 | | | |

| Charge air cooler system | | rpm | 1200 | 1500 | 1800 | 1900 |
|--|-----------|-------------------|-------------|-------------|-------------|-------------|
| Heat rejection to charge air cooler | IFN Power | kW | 74 | 102 | 106 | 99 |
| | | BTU/min | 4208 | 5801 | 6028 | 5630 |
| Charge air mass flow | IFN Power | kg/s | 0,53 | 0,67 | 0,72 | 0,7 |
| Charge air inlet temp. (Charge air temp after turbo compressor) | IFN Power | °C | 175 | 200 | 205 | 200 |
| | | °F | 347 | 392 | 401 | 392 |
|  See front page for important information Max allowable Charge air outlet temp. (Charge air temp after charge air cooler) | | °C | 40 | 45 | 55 | 50 |
| | | °F | 104 | 113 | 131 | 122 |
|  See front page for important information Maximum pressure drop over charge air cooler incl. piping | | kPa | 14 | | | |
| | | psi | 2,03 | | | |
| Charge air pressure (After charge air cooler) | | kPa | 213 | 235 | 212 | 200 |
| | | psi | 30,89 | 34,08 | 30,75 | 29,01 |
| Standard charge air cooler core area | | m ² | 1,3 | | | |
| | | foot ² | 13,99 | | | |

Cooling performance: 1,3 m² radiator and Pull 890 fan (fix ratio)

Cooling air flow and maximum additional external restriction at different radiator air temperatures based on 107°C TTT and 40% coolant. Valid at 1 atm.

| Engine speed | Engine power | Air on temp | | Air flow | | External restriction | |
|--------------------------|--------------|-------------|-----|-------------------|--------------------|----------------------|-------|
| | | | | m ³ /s | ft ³ /s | Pa | psi |
| rpm | kW hp | °C | °F | | | | |
| 1800 (0,88 fix ratio) | 515 700 | 50 | 122 | 7 | 247,2 | 295 | 0,043 |
| | | 52 | 126 | 7,4 | 261,3 | 225 | 0,033 |
| | | 53 | 127 | 7,6 | 268,4 | 180 | 0,026 |
| | | 55 | 131 | 7,9 | 279,0 | 100 | 0,015 |
| | | 57 | 135 | 8,3 | 293,1 | 0 | |

Cooling performance: 1,3 m² radiator and Push 890 fan (fix ratio)

Cooling air flow and maximum additional external restriction at different radiator air temperatures based on 107°C TTT and 40% coolant. Valid at 1 atm.

| Engine speed | Engine power | Air on temp | | Air flow | | External restriction | |
|--------------------------|--------------|-------------|-----|-------------------|--------------------|----------------------|-------|
| | | | | m ³ /s | ft ³ /s | Pa | psi |
| rpm | kW hp | °C | °F | | | | |
| 1800 (0,97 fix ratio) | 515 700 | 52 | 126 | 7,4 | 261,3 | 340 | 0,049 |
| | | 54 | 129 | 7,7 | 271,9 | 250 | 0,036 |
| | | 55 | 131 | 7,9 | 279,0 | 200 | 0,029 |
| | | 56 | 133 | 8,1 | 286,0 | 145 | 0,021 |
| | | 58 | 136 | 8,6 | 303,7 | 0 | |

Engine management system

| Functionality | Alternatives | | | Default setting |
|---------------------|-------------------------|--|--|-----------------|
| Governor mode | Isochronous | | | |
| Governor droop | 0 | | | |
| Governor response | Adjustable PI-constants | | | 1 |
| Idle speed | 600-900 | | | 700 |
| Stop function | Energized to run/Stop | | | |
| Preheating function | On/Off | | | |
| Lamp test | On/Off | | | |
| | | | | |
| | | | | |

| Engine sensors and switch settings | | Alarm level | | | Engine protection | |
|------------------------------------|-------------|-----------------------|---------------------|-------------|--|--|
| Parameter | Unit | Setting range | Default setting | Level | Action. Default/Alternative | |
| Oil temp | °C | Setting +5 | 125 | | Shut down, ON/OFF* | |
| Oil pressure | Low idle | kPa | 50 | 25,0 | Shut down, ON/OFF* | |
| | Rated speed | kPa | 300 | 275 | Shut down, ON/OFF* | |
| Oil level | | | | | | |
| Piston cooling pressure >1000 rpm | kPa | | | | | |
| Coolant temp | °C | 107 | 105 | | Shut down, ON/OFF* | |
| Coolant level | | See cooling system | On | | | |
| Fuel feed pressure | 1200rpm | kPa | 250 | | | |
| | | | | | | |
| Water in fuel | | | | | | |
| Crank case pressure | kPa | | | | Shut down, | |
| Air filter pressure drop | | | 5 | | | |
| Altitude, above sea | m | | | | Automatic derating, see section derating | |
| Charge air temp | °C | 85 | 80 | | Shut down, ON/OFF* | |
| Charge air pressure | kPa | Alarm map value +5kPa | map value +5kPa | | Shut down, ON/OFF* | |
| Engine speed | rpm | x % of rated speed | 120% of rated speed | Alarm level | Shut down, ON/OFF* | |
| | | | | | | |

* Off means no shut down, alarm only

| Parameter | Warning | Alarm | Derated 0% to engine protection map | Derated 100% to engine protection map | Forced idle after sec | Forced shut down after 2 sec |
|--------------------------|-------------------|-----------------|-------------------------------------|---------------------------------------|-----------------------|------------------------------|
| Coolant temp | 101°C | 107°C | 107°C | 108°C | N/A | N/A |
| Oil temp | 125°C | 127°C | 127°C | 130°C | N/A | N/A |
| Low oil pressure | Warning | Alarm | N/A | N/A | N/A | Alarm map value |
| High charge air temp | 80°C | 85°C | 85°C | 86°C | N/A | N/A |
| High charge air pressure | Warning map value | Alarm map value | Alarm map value | Alarm map value | N/A | N/A |
| Parameters | | | | | | |
| | | | | | | |

Electrical system

| | | | |
|-------------------------------------|---------------|--------------------|---------|
| Voltage and type | | | 24V |
| Alternator: | make | | Bosch |
| | output | A | 110/150 |
| | tacho output | Hz/alternator rev. | 6 |
| | drive ratio | | 3,9:1 |
| Starter motor: | make | | Melco |
| | type | | 105P70 |
| | output | kW | 7 |
| | | hp | 9,5 |
| Number of teeth on: | flywheel | | 153 |
| | starter motor | | 12 |
| Max wiring resistance main circuit | | mΩ | 2 |
| Cranking current at +20°C | | A | 280 |
| Crank engine speed at 20°C | | rpm | 150 |
| Starter motor battery capacity | max | Ah/A | 2x225 |
| | min at +5°C | Ah/A | |
| Inlet manifold heater (at 20 V) | | kW | 2 |
| Power relay for the manifold heater | | A | 1 |

Power take off

| | | rpm | 1200 | 1500 | 1800 | 1900 |
|--|-----------|--------|---------------------------|------|------|------|
| Front end belt pulley load. Direction of load viewed from flywheel side: | max left | kW | 26 | 33 | 40 | |
| | | hp | 35 | 45 | 54 | |
| | max down | kW | 60 | 75 | 90 | |
| | | hp | 82 | 102 | 122 | |
| | max right | kW | 26 | 33 | 40 | |
| | | hp | 35 | 45 | 54 | |
| Timing gear at compressor PTO max: | | Nm | 600 | | | |
| | | lbf ft | 443 | | | |
| Speed ratio direction of rotation viewed from flywheel side | | | 1,31:1 / Counterclockwise | | | |
| Timing gear at servo pump max: | | Nm | 100 | | | |
| | | lbf ft | 74 | | | |
| Speed ratio direction of rotation viewed from flywheel side | | | 1,58:1 / Counterclockwise | | | |
| Max allowed bending moment in flywheel housing | | Nm | 15000 | | | |
| | | lbf ft | 11063 | | | |
| Max. rear main bearing load | | N | 5000 | | | |
| | | lbf | 1124,0 | | | |

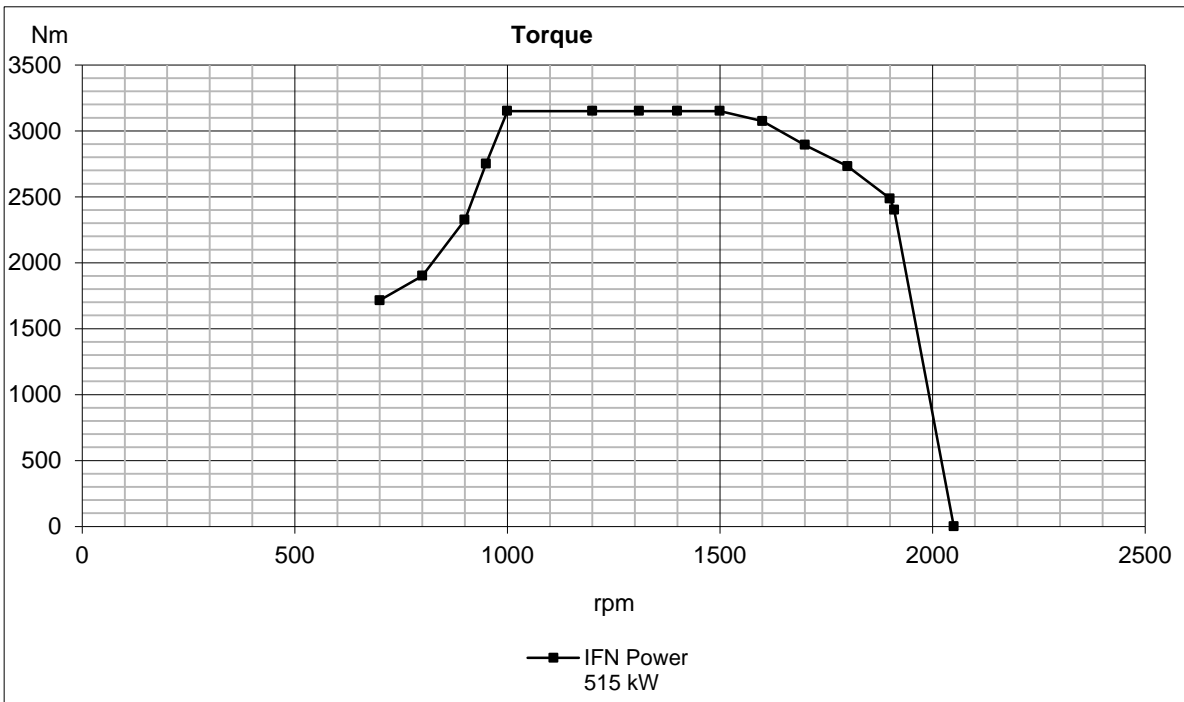
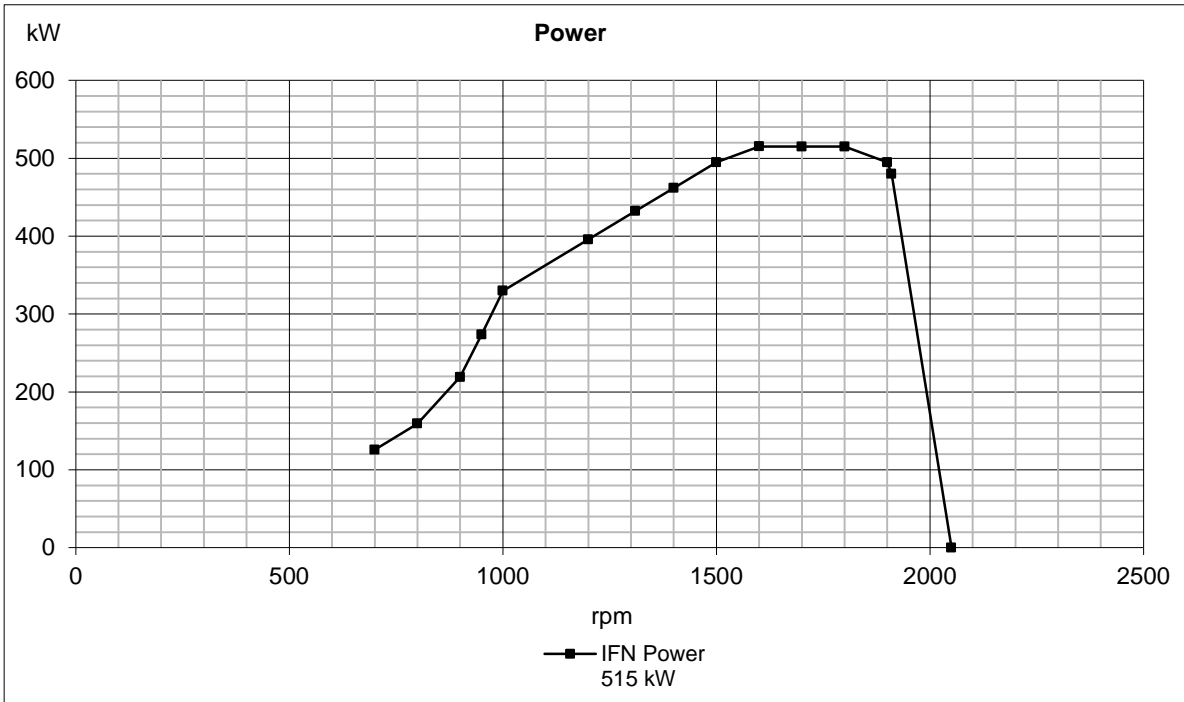

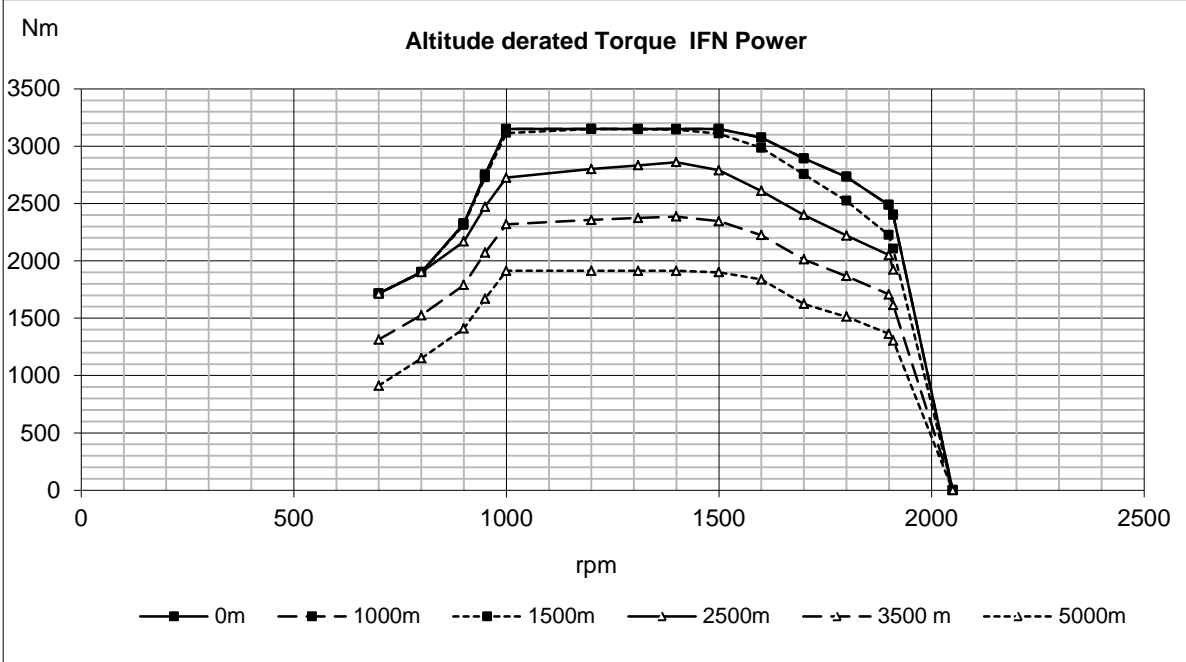

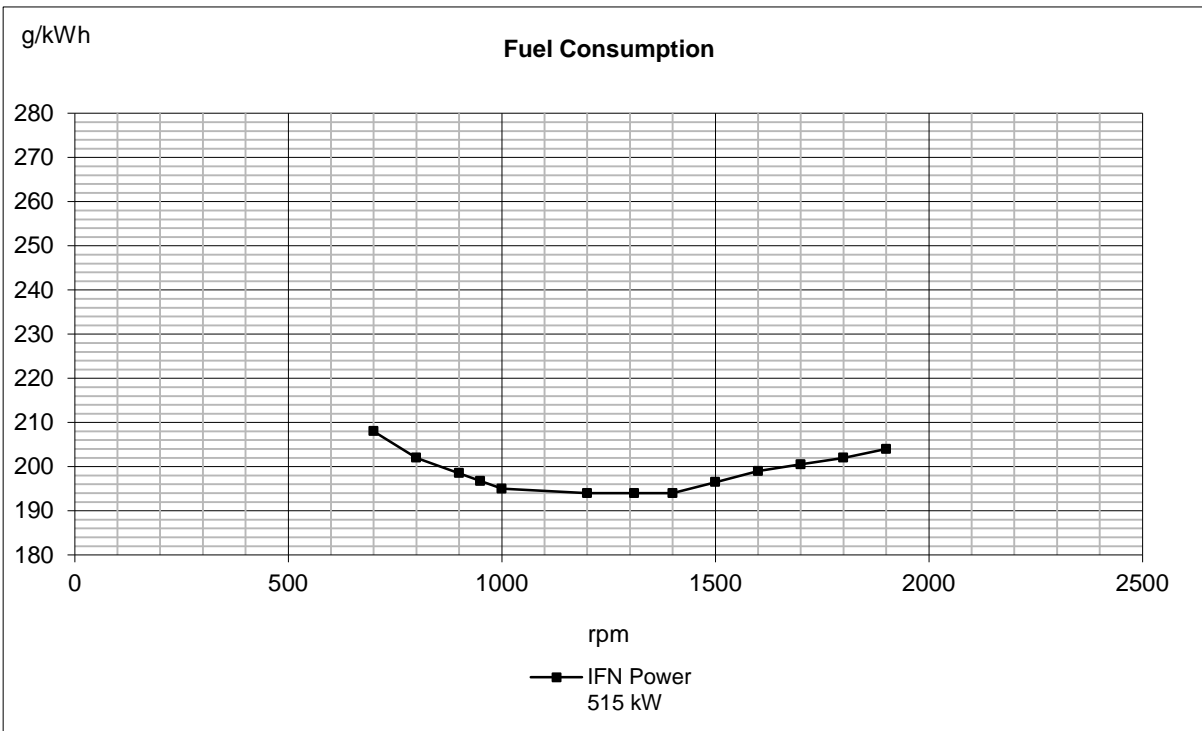
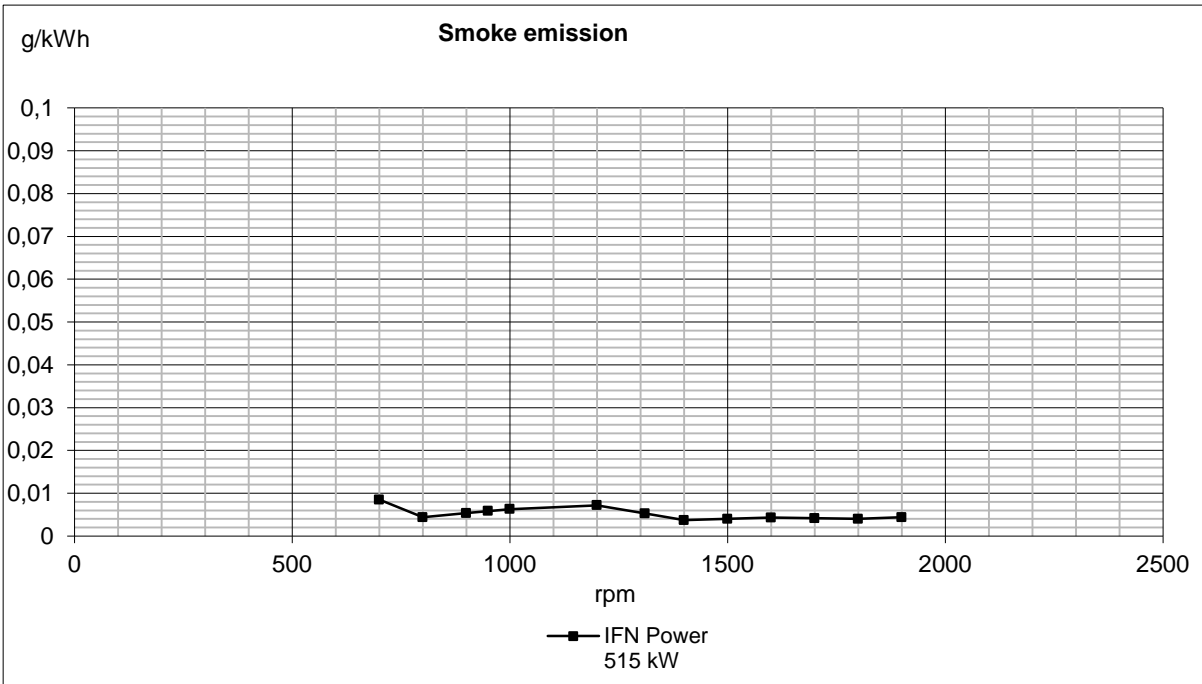

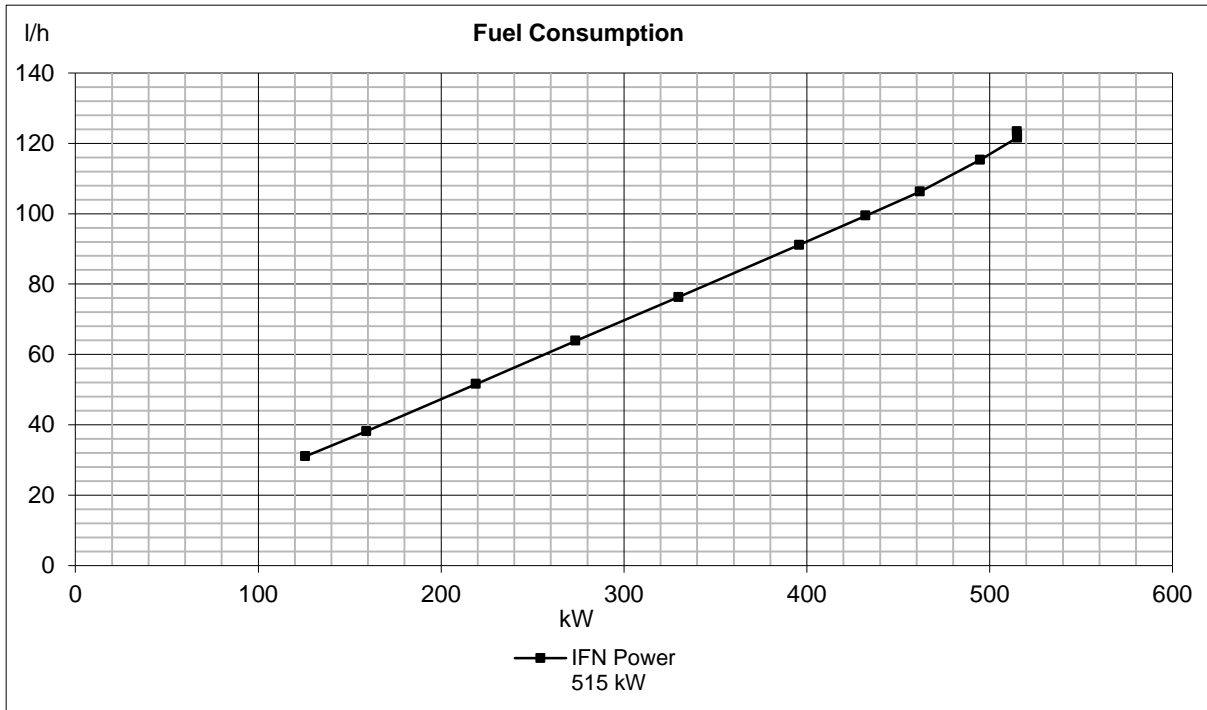

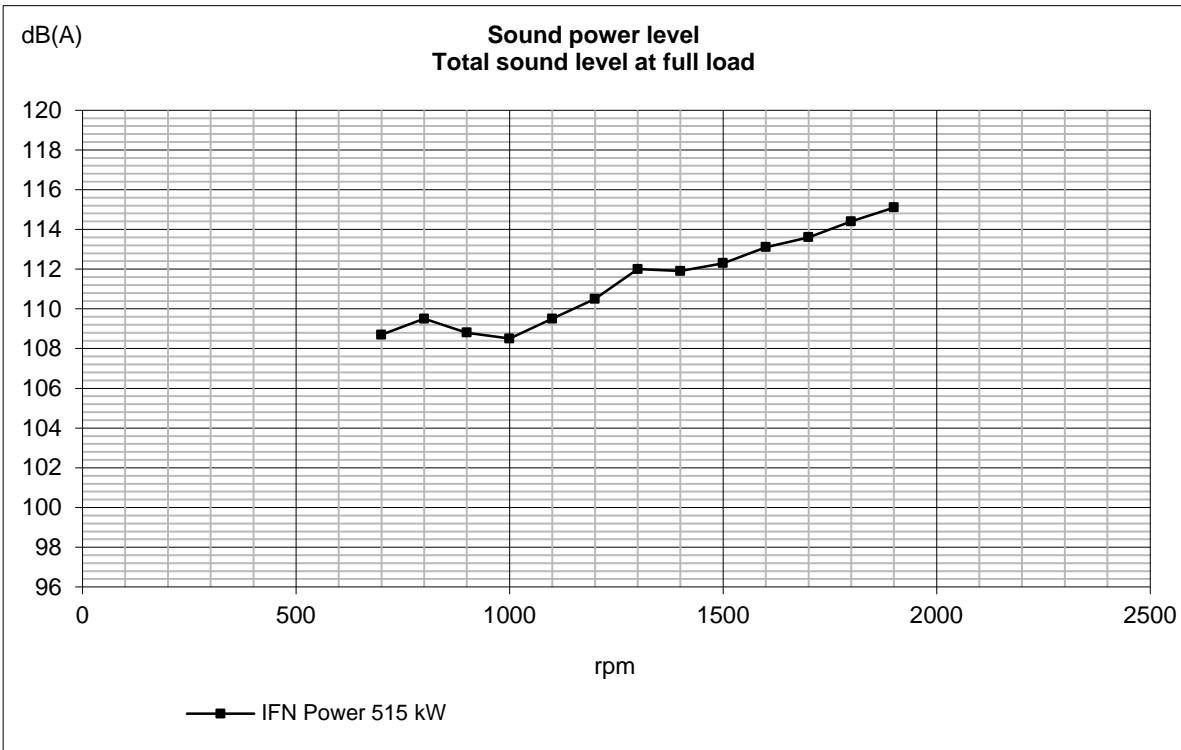
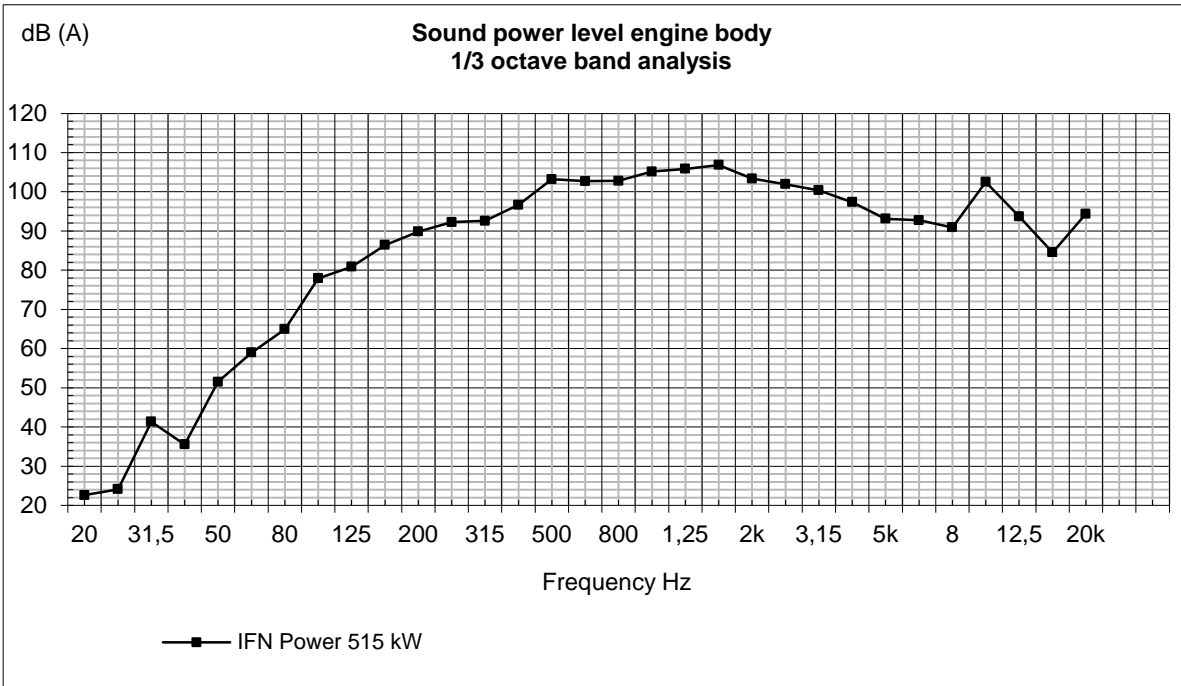

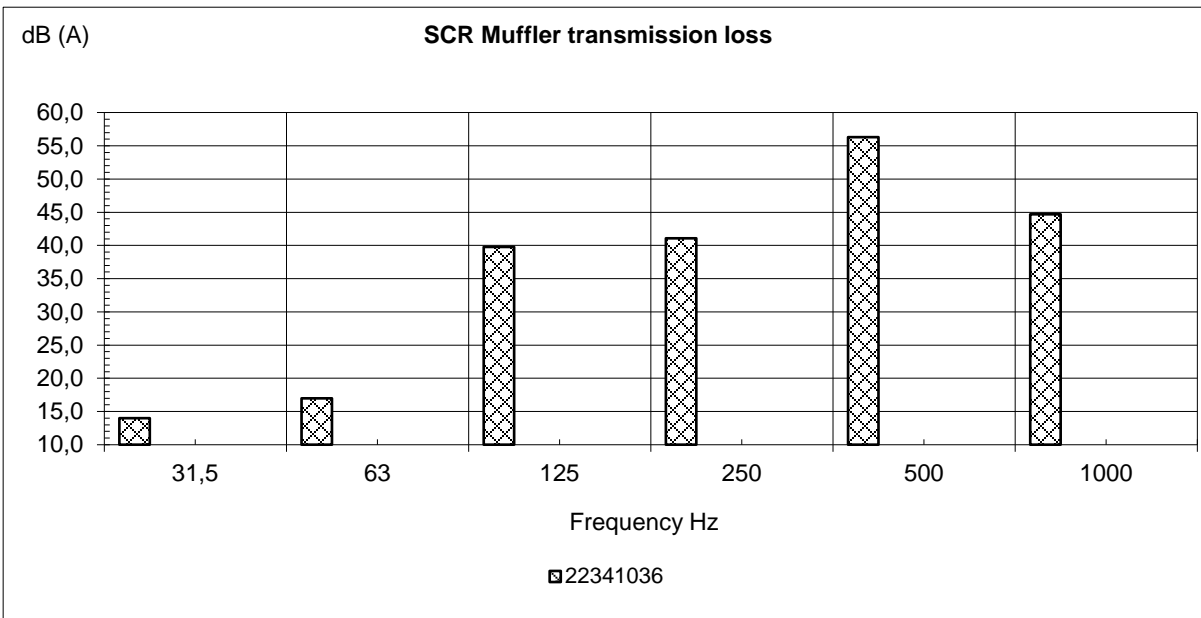
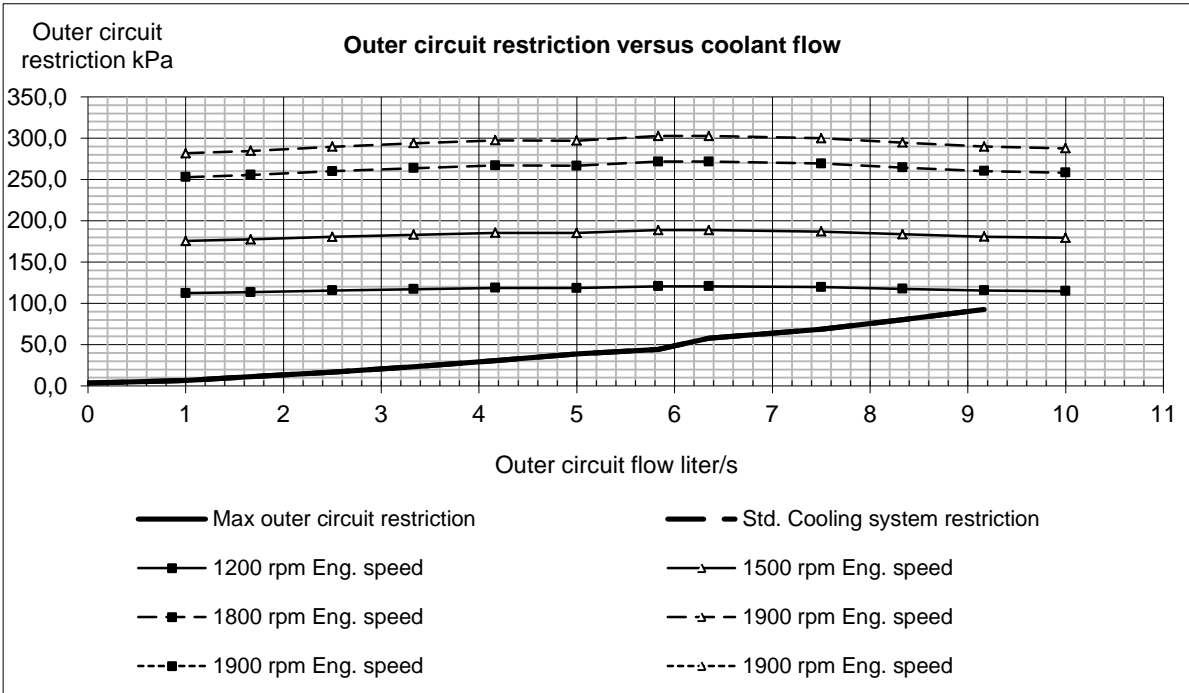

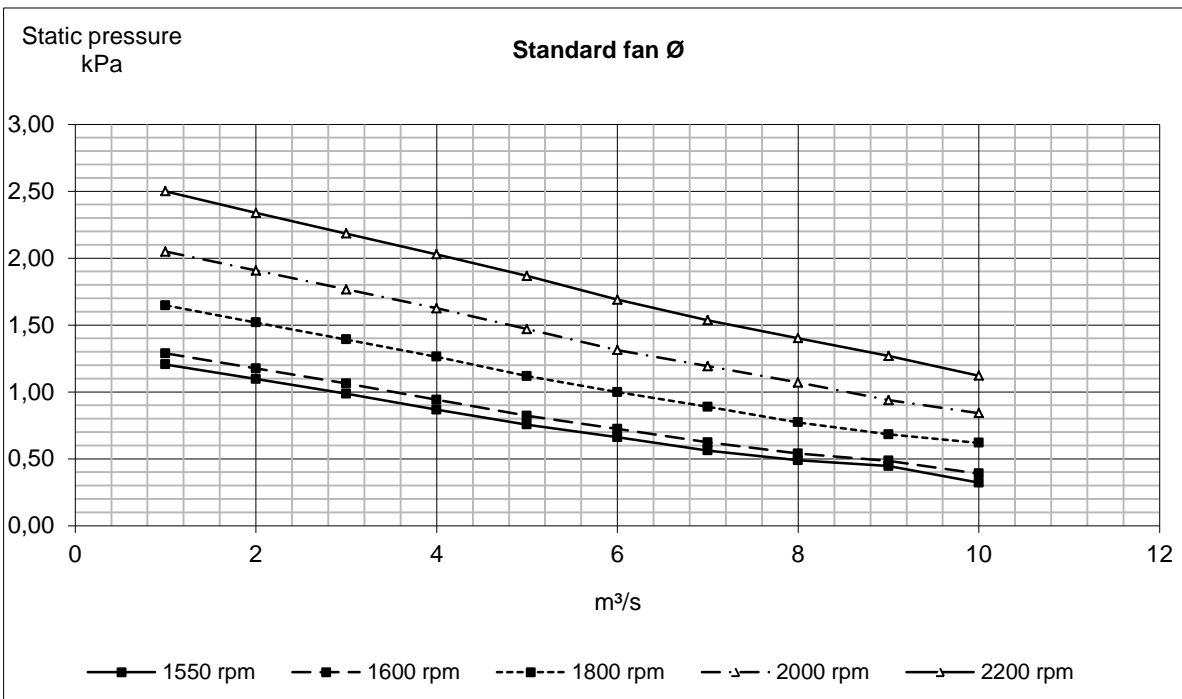
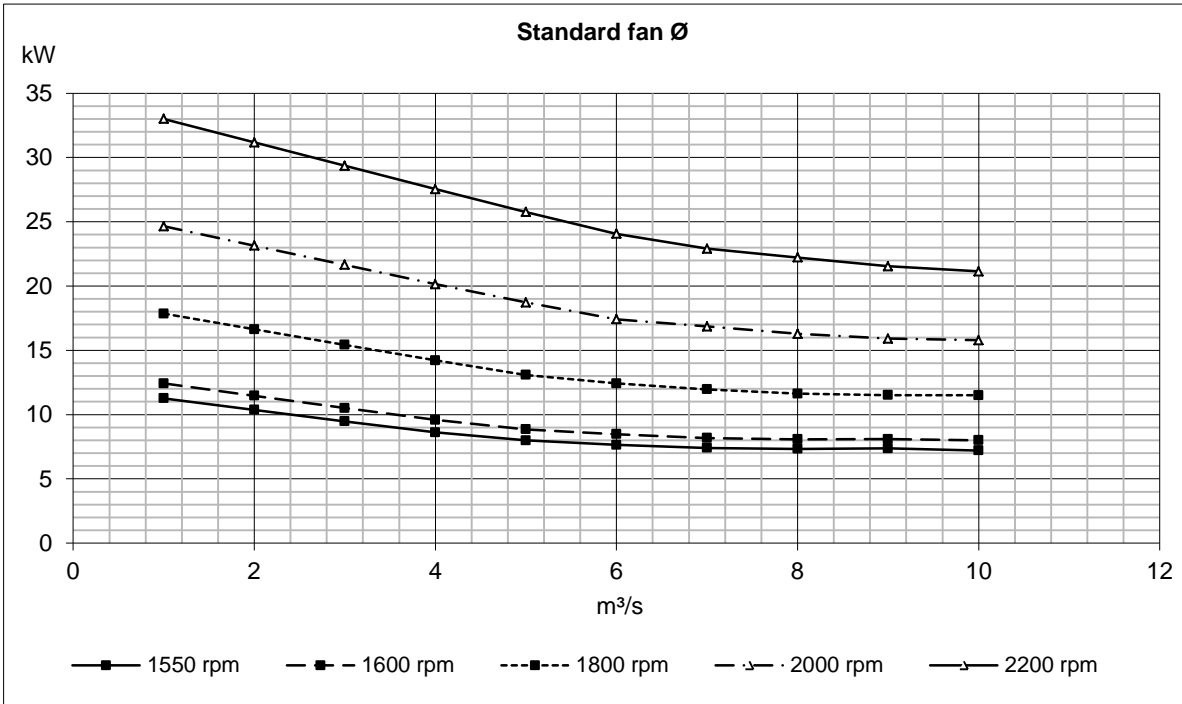

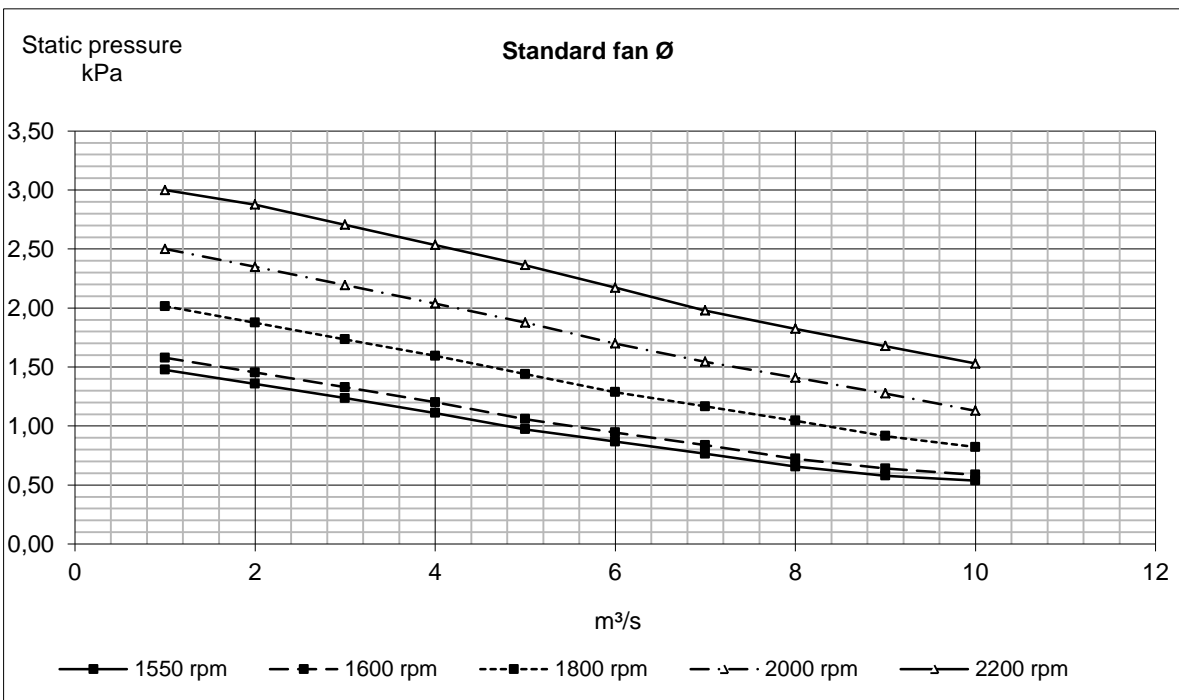
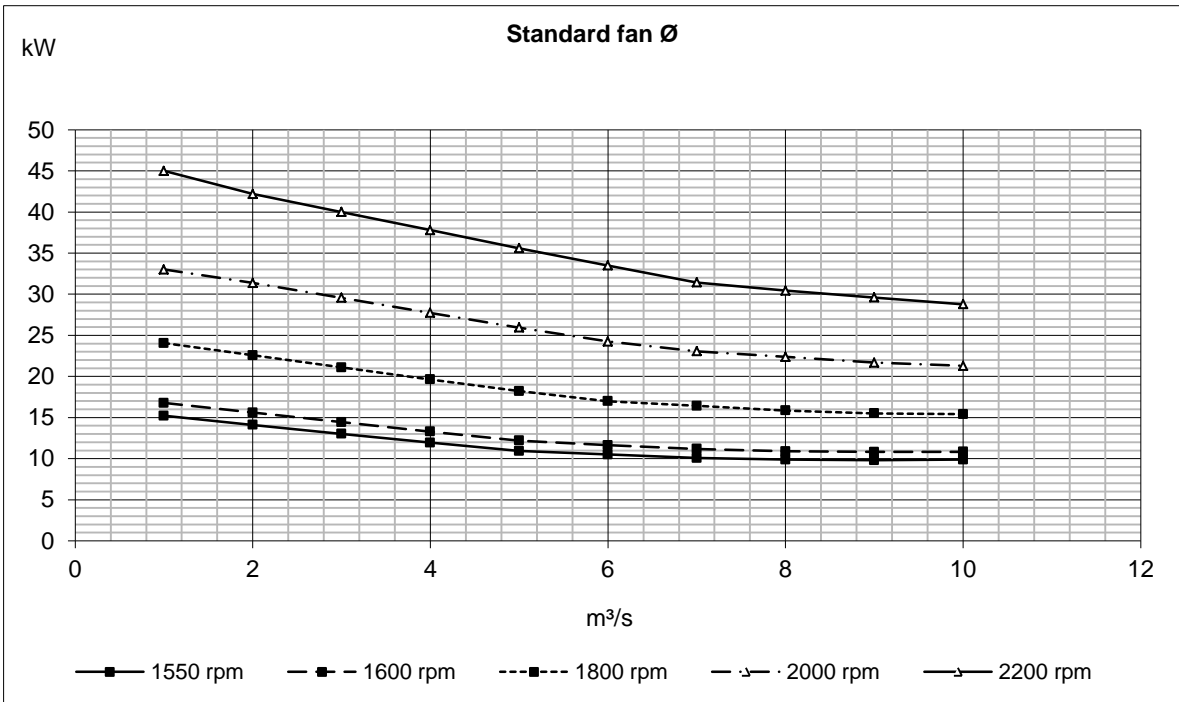

BSFC [g/kWh]

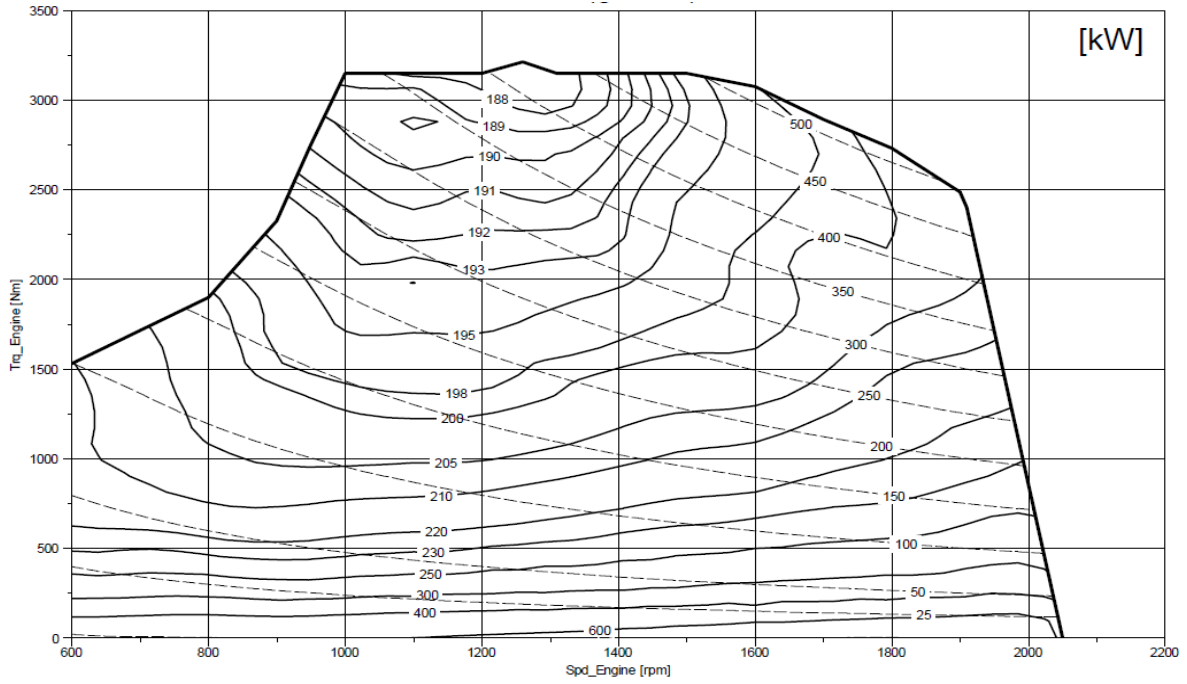

Fuel consumption [l/h]

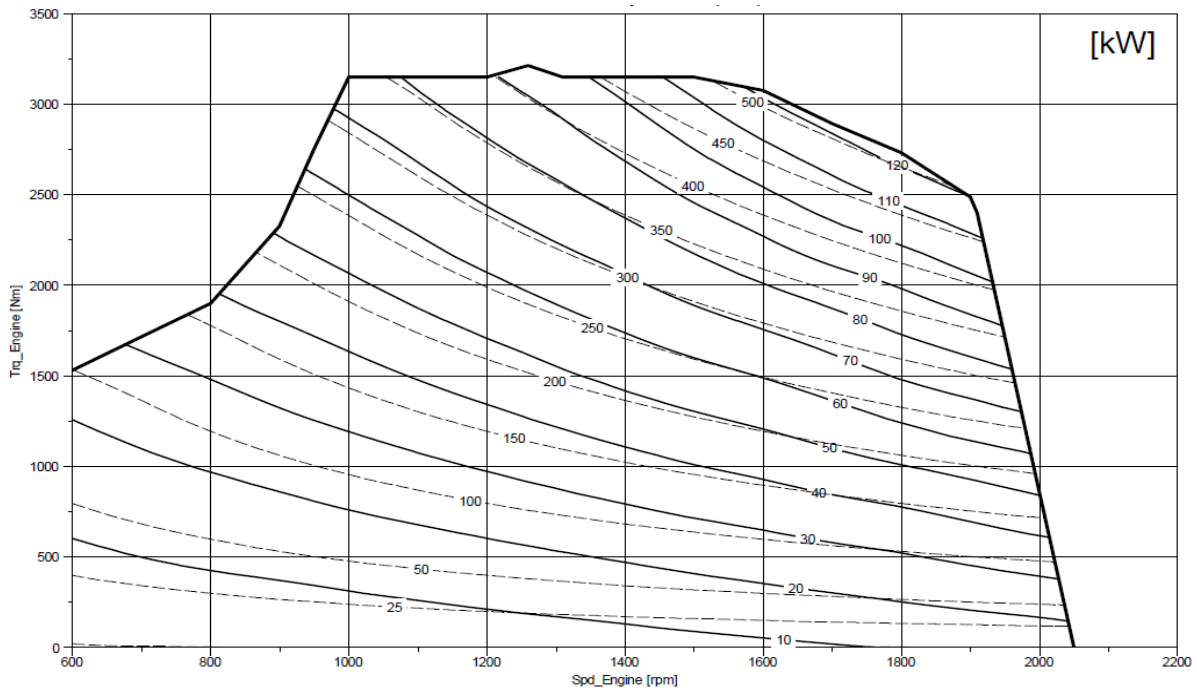

STAMFORD®

HCI 534C/544C - Winding 311

Technical  Data Sheet

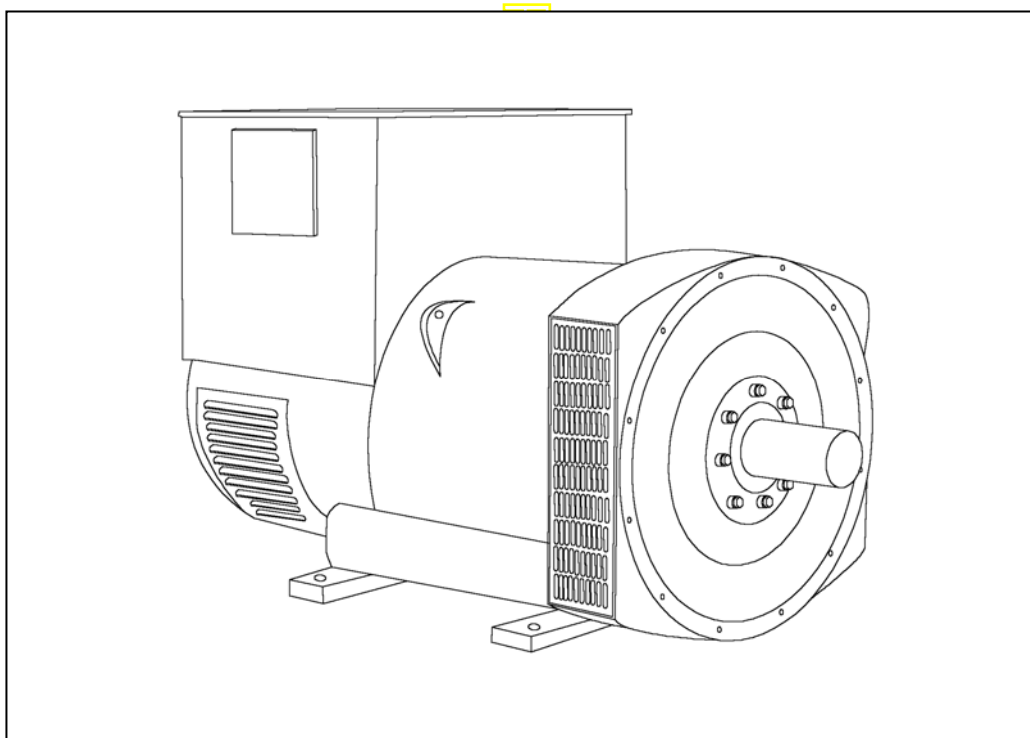

HCI534C/544C

SPECIFICATIONS & OPTIONS

STAMFORD

STANDARDS

Stamford industrial generators meet the requirements of BS EN 60034 and the relevant section of other international standards such as BS5000, VDE 0530, NEMA MG1-32, IEC34, CSA C22.2 100, AS1359.

Other standards and certifications can be considered on request.

VOLTAGE REGULATORS

AS440 AVR - STANDARD

With this self-excited system the main stator provides power via the Automatic Voltage Regulator (AVR) to the exciter stator. The high efficiency semi-conductors of the AVR ensure positive build-up from initial low levels of residual voltage.

The exciter rotor output is fed to the main rotor through a three-phase full-wave bridge rectifier. The rectifier is protected by a surge suppressor against surges caused, for example, by short circuit or out-of-phase paralleling.

The AS440 will support a range of electronic accessories, including a 'droop' Current Transformer (CT) to permit parallel operation with other ac generators.

MX341 AVR

This sophisticated AVR is incorporated into the Stamford Permanent Magnet Generator (PMG) control system.

The PMG provides power via the AVR to the main exciter, giving a source of constant excitation power independent of generator output. The main exciter output is then fed to the main rotor through a full wave bridge, protected by a surge suppressor.

The AVR has in-built protection against sustained over-excitation, caused by internal or external faults. This de-excites the machine after a minimum of 5 seconds.

An engine relief load acceptance feature can enable full load to be applied to the generator in a single step.

If three-phase sensing is required with the PMG system the MX321 AVR must be used.

We recommend three-phase sensing for applications with greatly unbalanced or highly non-linear loads.

MX321 AVR

The most sophisticated of all our AVRs combines all the features of the MX341 with, additionally, three-phase rms sensing, for improved regulation and performance.

Over voltage protection is built-in and short circuit current level adjustments is an optional facility.

WINDINGS & ELECTRICAL PERFORMANCE

All generator stators are wound to 2/3 pitch. This eliminates triplen (3rd, 9th, 15th ...) harmonics on the voltage waveform and is found to be the optimum design for trouble-free supply of non-linear loads. The 2/3 pitch design avoids excessive neutral currents sometimes seen with higher winding pitches, when in parallel with the mains. A fully connected damper winding reduces oscillations during paralleling. This winding, with the 2/3 pitch and carefully selected pole and tooth designs, ensures very low waveform distortion.

TERMINALS & TERMINAL BOX

Standard generators are 3-phase reconnectable with 12 ends brought out to the terminals, which are mounted on a cover at the non-drive end of the generator. A sheet steel terminal box contains the AVR and provides ample space for the customers' wiring and gland arrangements. It has removable panels for easy access.

SHAFT & KEYS

All generator rotors are dynamically balanced to better than BS6861:Part 1 Grade 2.5 for minimum vibration in operation. Two bearing generators are balanced with a half key.

INSULATION/IMPREGNATION

The insulation system is class 'H'.

All wound components are impregnated with materials and processes designed specifically to provide the high build required for static windings and the high mechanical strength required for rotating components.

QUALITY ASSURANCE

Generators are manufactured using production procedures having a quality assurance level to BS EN ISO 9001.

The stated voltage regulation may not be maintained in the presence of certain radio transmitted signals. Any change in performance will fall within the limits of Criteria 'B' of EN 61000-6-2:2001. At no time will the steady-state voltage regulation exceed 2%.

DE RATES

All values tabulated on page 8 are subject to the following reductions

5% when air inlet filters are fitted.

3% for every 500 metres by which the operating altitude exceeds 1000 metres above mean sea level.

3% for every 5°C by which the operational ambient temperature exceeds 40°C.

Note: Requirement for operating in an ambient exceeding 60°C must be referred to the factory.

NB Continuous development of our products entitles us to change specification details without notice, therefore they must not be regarded as binding.

Front cover drawing typical of product range.

HCI534C/544C



WINDING 311

| | | | | | | | | |
|--|--|--------------------------|--------------------------|---------|------------------------------------|---------|---------|---------|
| CONTROL SYSTEM | SEPARATELY EXCITED BY P.M.G. | | | | | | | |
| A.V.R. | MX321 | MX341 | | | | | | |
| VOLTAGE REGULATION | ± 0.5 % | ± 1.0 % | With 4% ENGINE GOVERNING | | | | | |
| SUSTAINED SHORT CIRCUIT | REFER TO SHORT CIRCUIT DECREMENT CURVES (page 7) | | | | | | | |
| CONTROL SYSTEM | SELF EXCITED | | | | | | | |
| A.V.R. | AS440 | | | | | | | |
| VOLTAGE REGULATION | ± 1.0 % | With 4% ENGINE GOVERNING | | | | | | |
| SUSTAINED SHORT CIRCUIT | SERIES 4 CONTROL DOES NOT SUSTAIN A SHORT CIRCUIT CURRENT | | | | | | | |
| INSULATION SYSTEM | CLASS H | | | | | | | |
| PROTECTION | IP23 | | | | | | | |
| RATED POWER FACTOR | 0.8 | | | | | | | |
| STATOR WINDING | DOUBLE LAYER LAP | | | | | | | |
| WINDING PITCH | TWO THIRDS | | | | | | | |
| WINDING LEADS | 12 | | | | | | | |
| STATOR WDG. RESISTANCE | 0.0065 Ohms PER PHASE AT 22°C SERIES STAR CONNECTED | | | | | | | |
| ROTOR WDG. RESISTANCE | 1.55 Ohms at 22°C | | | | | | | |
| EXCITER STATOR RESISTANCE | 17 Ohms at 22°C | | | | | | | |
| EXCITER ROTOR RESISTANCE | 0.092 Ohms PER PHASE AT 22°C | | | | | | | |
| R.F.I. SUPPRESSION | BS EN 61000-6-2 & BS EN 61000-6-4, VDE 0875G, VDE 0875N. refer to factory for others | | | | | | | |
| WAVEFORM DISTORTION | NO LOAD < 1.5% NON-DISTORTING BALANCED LINEAR LOAD < 5.0% | | | | | | | |
| MAXIMUM OVERSPEED | 2250 Rev/Min | | | | | | | |
| BEARING DRIVE END | BALL. 6220 (ISO) | | | | | | | |
| BEARING NON-DRIVE END | BALL. 6314 (ISO) | | | | | | | |
| | 1 BEARING | | | | 2 BEARING | | | |
| WEIGHT COMP. GENERATOR | 1263 kg | | | | 1275 kg | | | |
| WEIGHT WOUND STATOR | 584 kg | | | | 584 kg | | | |
| WEIGHT WOUND ROTOR | 502 kg | | | | 473 kg | | | |
| WR ² INERTIA | 6.8928 kgm ² | | | | 6.6149 kgm ² | | | |
| SHIPPING WEIGHTS in a crate | 1355 kg | | | | 1395 kg | | | |
| PACKING CRATE SIZE | 166 x 87 x 124(cm) | | | | 166 x 87 x 124(cm) | | | |
| | 50 Hz | | | | 60 Hz | | | |
| TELEPHONE INTERFERENCE | THF<2% | | | | TIF<50 | | | |
| COOLING AIR | 1.035 m ³ /sec 2202 cfm | | | | 1.312 m ³ /sec 2780 cfm | | | |
| VOLTAGE SERIES STAR | 380/220 | 400/231 | 415/240 | 440/254 | 416/240 | 440/254 | 460/266 | 480/277 |
| VOLTAGE PARALLEL STAR | 190/110 | 200/115 | 208/120 | 220/127 | 208/120 | 220/127 | 230/133 | 240/138 |
| VOLTAGE SERIES DELTA | 220/110 | 230/115 | 240/120 | 254/127 | 240/120 | 254/127 | 266/133 | 277/138 |
| KVA BASE RATING FOR REACTANCE VALUES | 455 | 500 | 455 | 450 | 525 | 550 | 581 | 594 |
| X _d DIR. AXIS SYNCHRONOUS | 3.30 | 3.28 | 2.77 | 2.44 | 3.94 | 3.69 | 3.57 | 3.35 |
| X' _d DIR. AXIS TRANSIENT | 0.18 | 0.18 | 0.15 | 0.13 | 0.18 | 0.17 | 0.16 | 0.15 |
| X'' _d DIR. AXIS SUBTRANSIENT | 0.13 | 0.13 | 0.11 | 0.10 | 0.13 | 0.12 | 0.12 | 0.11 |
| X _q QUAD. AXIS REACTANCE | 2.69 | 2.67 | 2.25 | 1.98 | 3.12 | 2.92 | 2.82 | 2.65 |
| X'' _q QUAD. AXIS SUBTRANSIENT | 0.27 | 0.26 | 0.22 | 0.20 | 0.34 | 0.32 | 0.31 | 0.29 |
| X _L LEAKAGE REACTANCE | 0.07 | 0.07 | 0.06 | 0.05 | 0.08 | 0.07 | 0.07 | 0.07 |
| X ₂ NEGATIVE SEQUENCE | 0.19 | 0.19 | 0.16 | 0.14 | 0.23 | 0.22 | 0.21 | 0.20 |
| X ₀ ZERO SEQUENCE | 0.11 | 0.11 | 0.09 | 0.08 | 0.11 | 0.10 | 0.10 | 0.09 |
| REACTANCES ARE SATURATED VALUES ARE PER UNIT AT RATING AND VOLTAGE INDICATED | | | | | | | | |
| T' _d TRANSIENT TIME CONST. | 0.08s | | | | | | | |
| T'' _d SUB-TRANSTIME CONST. | 0.012s | | | | | | | |
| T' _{do} O.C. FIELD TIME CONST. | 2s | | | | | | | |
| T _a ARMATURE TIME CONST. | 0.017s | | | | | | | |
| SHORT CIRCUIT RATIO | 1/X _d | | | | | | | |

50
Hz

HCI534C/544C
Winding 311

STAMFORD

THREE PHASE EFFICIENCY CURVES

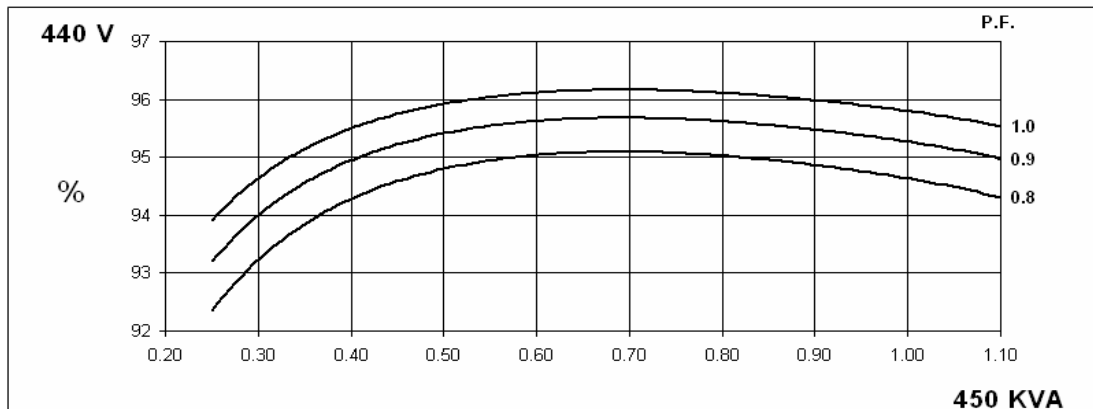
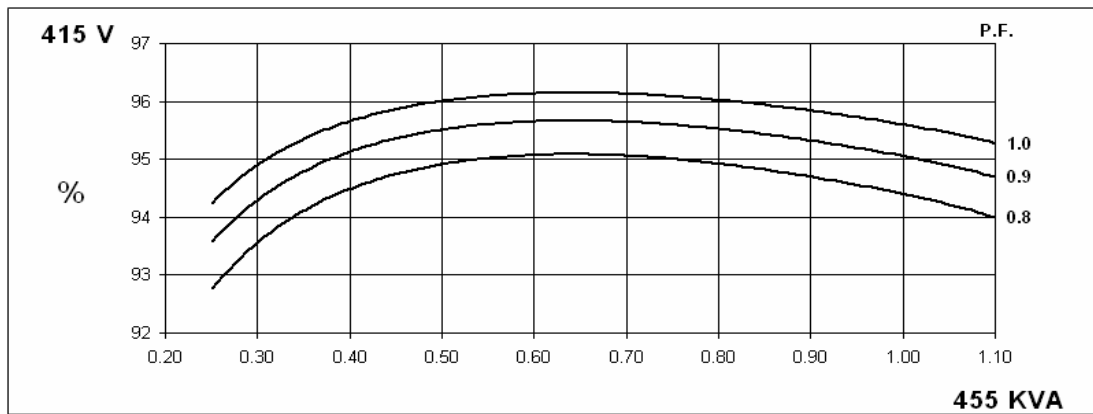
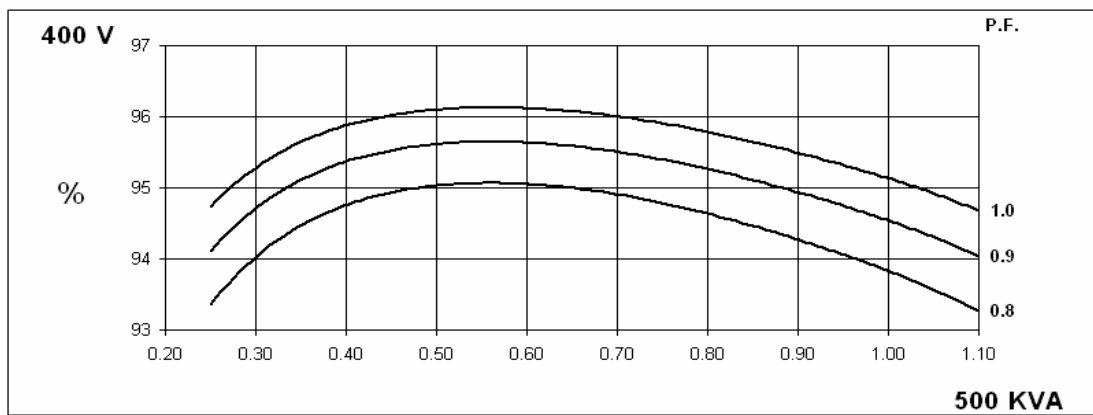
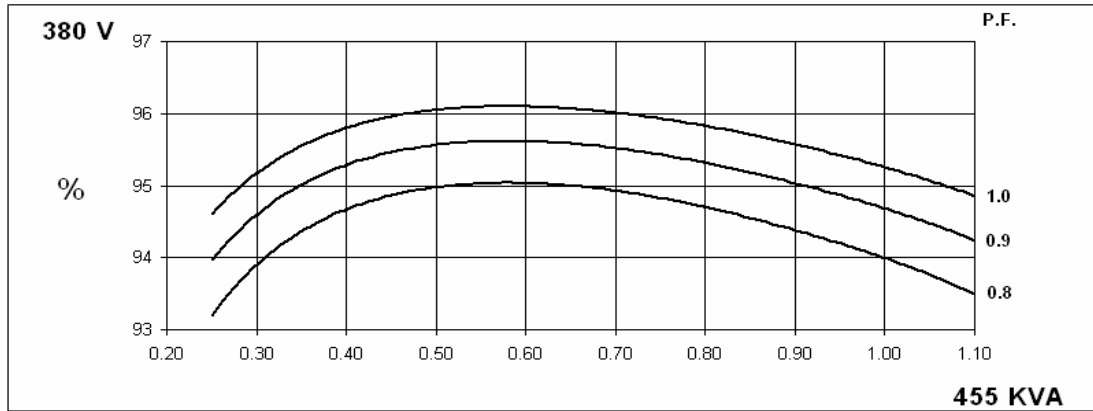

60
Hz

HCI534C/544C
Winding 311

STAMFORD

THREE PHASE EFFICIENCY CURVES

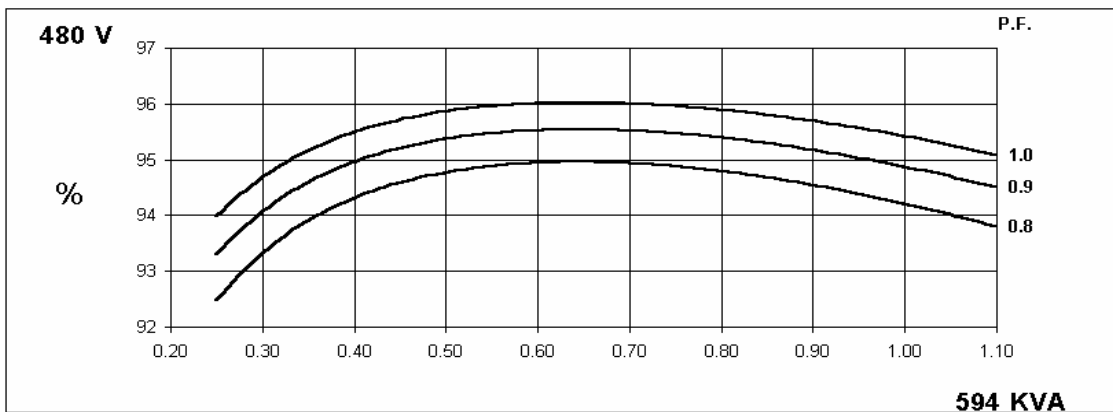
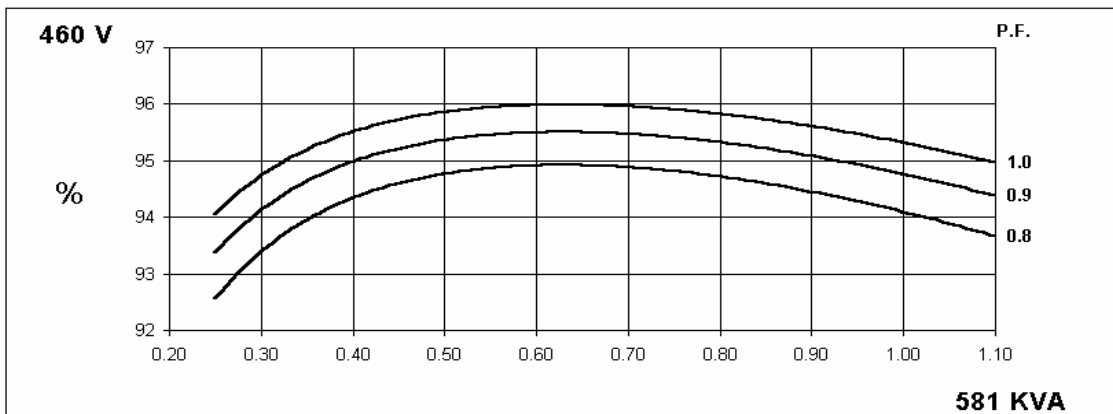
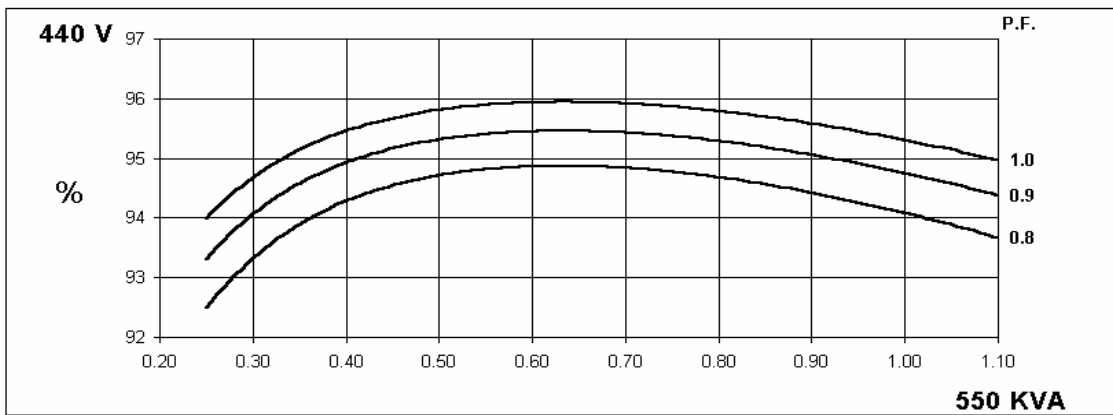
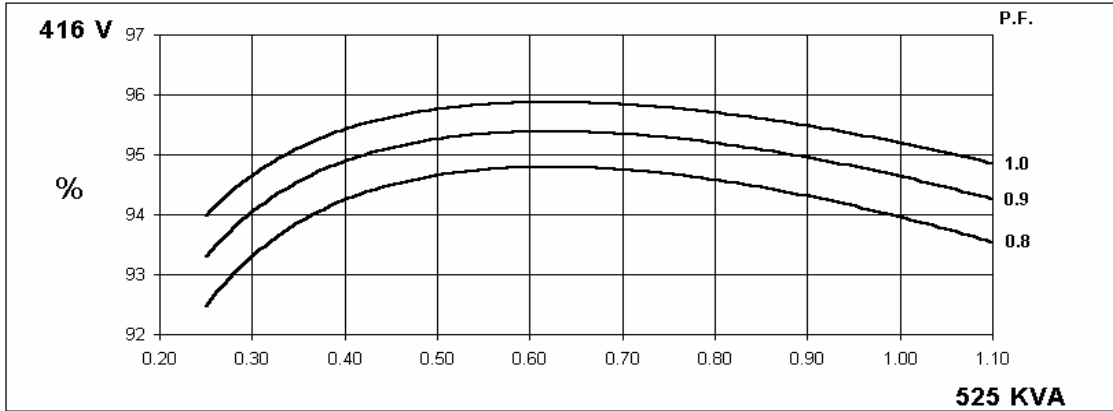

Locked Rotor Motor Starting Curve

50
Hz

MX

SX

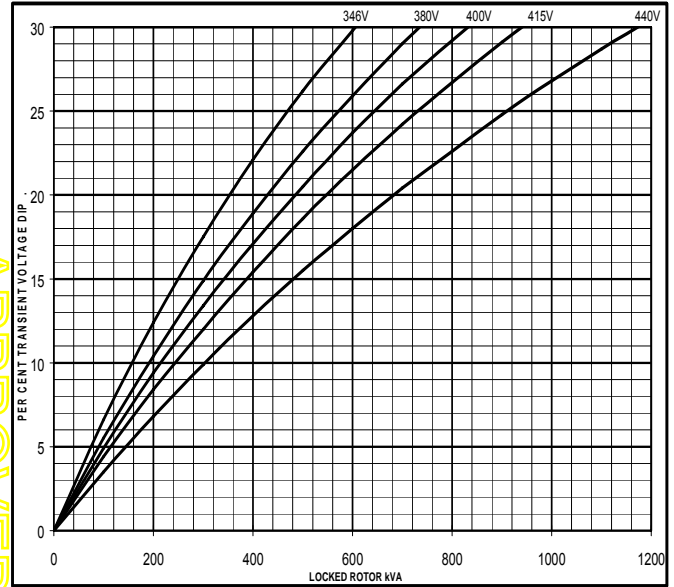
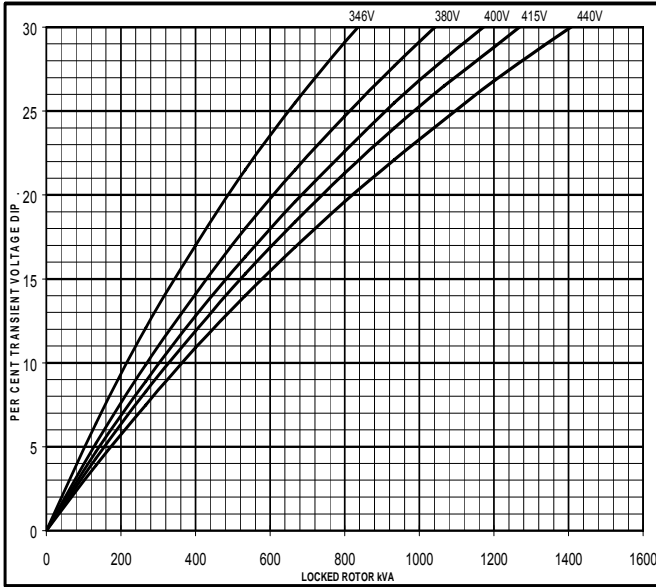

60
Hz

MX

SX

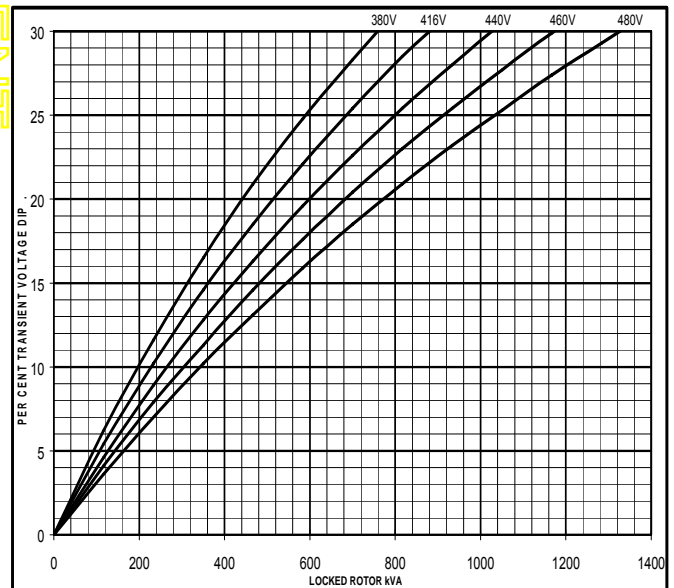
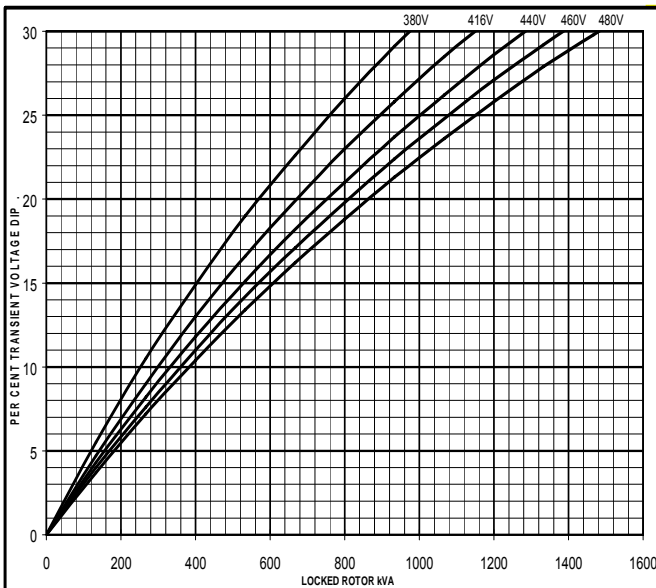

APPROVED DOCUMENT

**Three-phase Short Circuit Decrement Curve. No-load Excitation at Rated Speed
Based on star (wye) connection.**

50
Hz

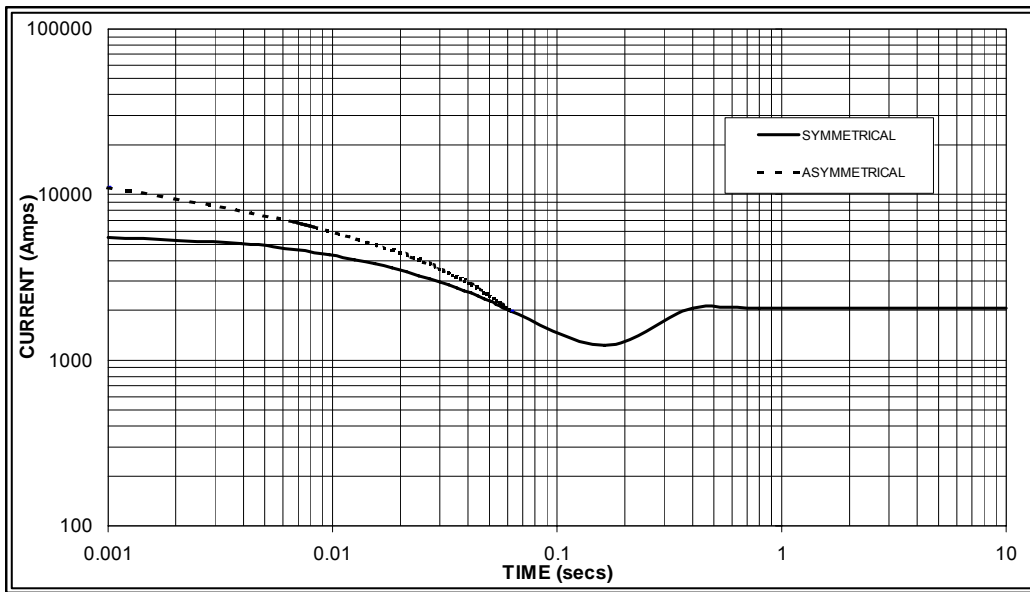

Sustained Short Circuit = 2,050 Amps



60
Hz

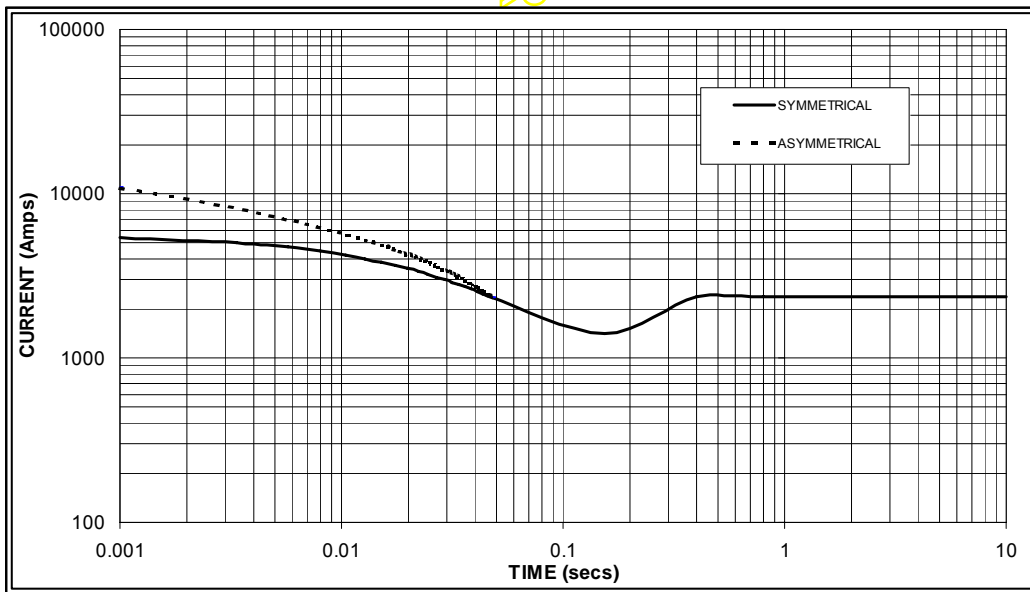

Sustained Short Circuit = 2,350 Amps

Note 1

The following multiplication factors should be used to adjust the values from curve between time 0.001 seconds and the minimum current point in respect of nominal operating voltage :

| 50Hz | | 60Hz | |
|---------|--------|---------|--------|
| Voltage | Factor | Voltage | Factor |
| 380v | X 1.00 | 416v | X 1.00 |
| 400v | X 1.03 | 440v | X 1.06 |
| 415v | X 1.05 | 460v | X 1.12 |
| 440v | X 1.07 | 480v | X 1.20 |

The sustained current value is constant irrespective of voltage level

Note 2

The following multiplication factor should be used to convert the values calculated in accordance with NOTE 1 to those applicable to the various types of short circuit :

| | 3-phase | 2-phase L-L | 1-phase L-N |
|-------------------------|---------|-------------|-------------|
| Instantaneous | x 1.00 | x 0.87 | x 1.30 |
| Minimum | x 1.00 | x 1.80 | x 3.20 |
| Sustained | x 1.00 | x 1.50 | x 2.50 |
| Max. sustained duration | 10 sec. | 5 sec. | 2 sec. |

All other times are unchanged

Note 3

Curves are drawn for Star (Wye) connected machines. For other connections the following multipliers should be applied to current values as shown :

Parallel Star = Curve current value X 2

Series Delta = Curve current value X 1.732

HCI534C/544C

STAMFORD

Winding 311 0.8 Power Factor

RATINGS

| Class - Temp Rise | Cont. F - 105/40°C | | | | Cont. H - 125/40°C | | | | Standby - 150/40°C | | | | Standby - 163/27°C | | | | |
|-------------------|--------------------|------|------|------|--------------------|------|------|------|--------------------|------|------|------|--------------------|------|------|------|-----|
| 50 Hz | Series Star (V) | 380 | 400 | 415 | 440 | 380 | 400 | 415 | 440 | 380 | 400 | 415 | 440 | 380 | 400 | 415 | 440 |
| | Parallel Star (V) | 190 | 200 | 208 | 220 | 190 | 200 | 208 | 220 | 190 | 200 | 208 | 220 | 190 | 200 | 208 | 220 |
| | Series Delta (V) | 220 | 230 | 240 | 254 | 220 | 230 | 240 | 254 | 220 | 230 | 240 | 254 | 220 | 230 | 240 | 254 |
| kVA | 400 | 445 | 400 | 400 | 455 | 500 | 455 | 450 | 478 | 512 | 478 | 478 | 500 | 520 | 500 | 495 | |
| kW | 320 | 356 | 320 | 320 | 364 | 400 | 364 | 360 | 382 | 410 | 382 | 382 | 400 | 416 | 400 | 396 | |
| Efficiency (%) | 94.5 | 94.3 | 94.8 | 94.9 | 94.0 | 93.8 | 94.4 | 94.6 | 93.8 | 93.7 | 94.2 | 94.4 | 93.5 | 93.6 | 94.0 | 94.3 | |
| kW Input | 339 | 378 | 338 | 337 | 387 | 426 | 386 | 381 | 408 | 437 | 406 | 405 | 428 | 444 | 425 | 420 | |

| | | | | | | | | | | | | | | | | | |
|----------------|-------------------|------|------|------|------|------|------|------|------|------|------|------|------|------|------|------|-----|
| 60 Hz | Series Star (V) | 416 | 440 | 460 | 480 | 416 | 440 | 460 | 480 | 416 | 440 | 460 | 480 | 416 | 440 | 460 | 480 |
| | Parallel Star (V) | 208 | 220 | 230 | 240 | 208 | 220 | 230 | 240 | 208 | 220 | 230 | 240 | 208 | 220 | 230 | 240 |
| | Delta (V) | 240 | 254 | 266 | 277 | 240 | 254 | 266 | 277 | 240 | 254 | 266 | 277 | 240 | 254 | 266 | 277 |
| kVA | 481 | 500 | 531 | 538 | 525 | 550 | 581 | 594 | 550 | 581 | 613 | 625 | 569 | 600 | 631 | 644 | |
| kW | 385 | 400 | 425 | 430 | 420 | 440 | 465 | 475 | 440 | 465 | 490 | 500 | 455 | 480 | 505 | 515 | |
| Efficiency (%) | 94.3 | 94.4 | 94.4 | 94.5 | 94.0 | 94.1 | 94.1 | 94.2 | 93.8 | 93.9 | 93.9 | 94.0 | 93.6 | 93.7 | 93.7 | 93.9 | |
| kW Input | 408 | 424 | 450 | 455 | 447 | 468 | 494 | 504 | 469 | 495 | 522 | 532 | 486 | 512 | 539 | 549 | |

DIMENSIONS

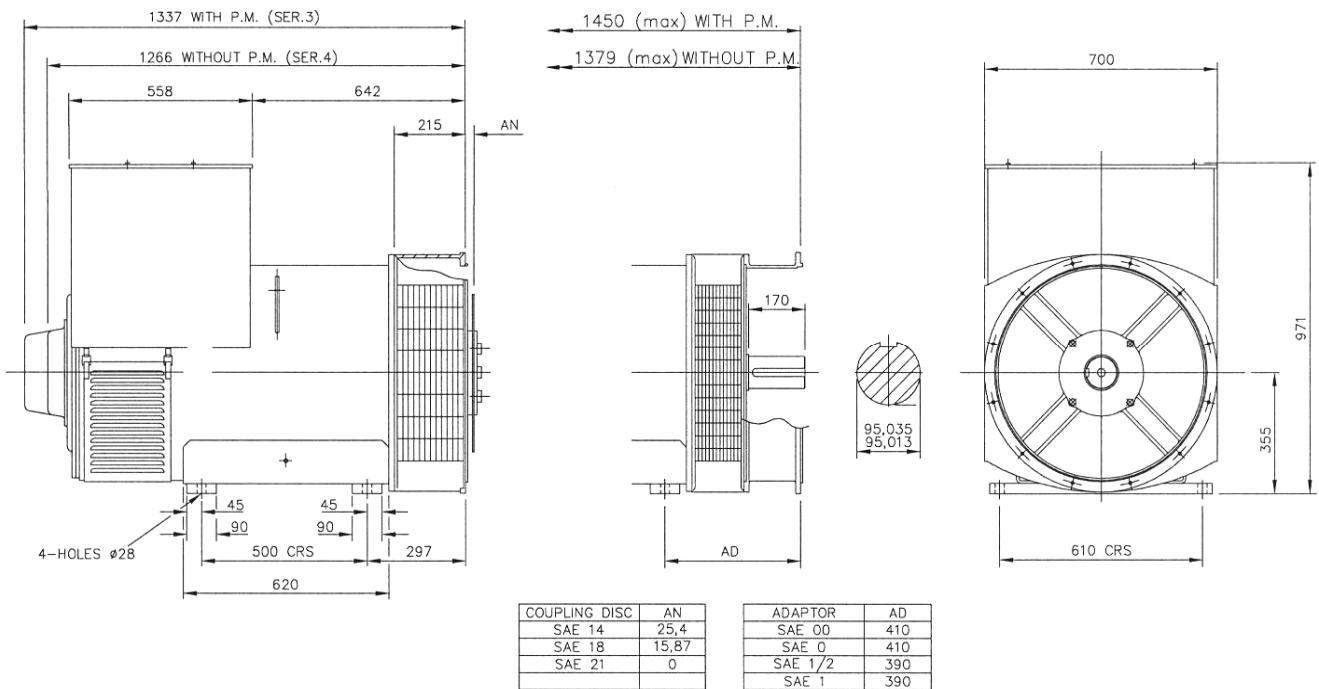

APPROVED DOCUMENT

STAMFORD

Head Office Address:
Barnack Road, Stamford
Lincolnshire, PE9 2NB
United Kingdom
Tel: +44 (0) 1780 484000
Fax: +44 (0) 1780 484100

www.cumminsgeneratortechnologies.com

Copyright 2010, Cummins Generator Technologies Ltd, All Rights Reserved
Stamford and AvK are registered trade marks of Cummins Generator Technologies Ltd
Cummins and the Cummins logo are registered trade marks of Cummins Inc.

STAMFORD®

HCI 534D/544D - Winding 311

Technical  Data Sheet

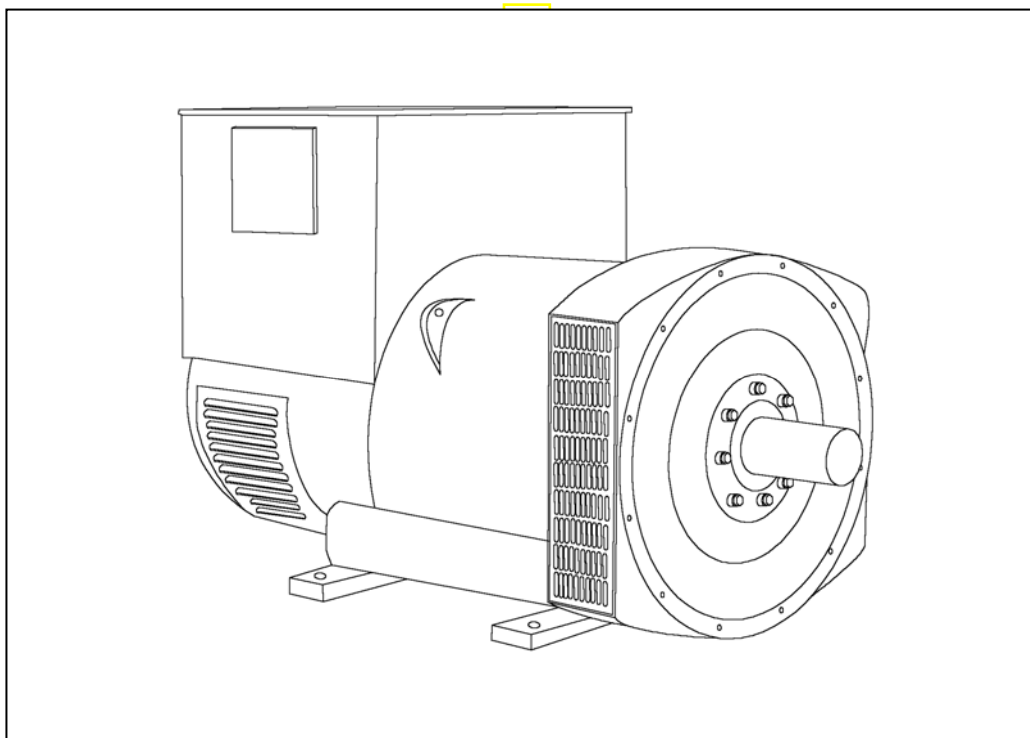

HCI534D/544D

SPECIFICATIONS & OPTIONS

STAMFORD

STANDARDS

Stamford industrial generators meet the requirements of BS EN 60034 and the relevant section of other international standards such as BS5000, VDE 0530, NEMA MG1-32, IEC34, CSA C22.2 100, AS1359.

Other standards and certifications can be considered on request.

VOLTAGE REGULATORS

AS440 AVR - STANDARD

With this self-excited system the main stator provides power via the Automatic Voltage Regulator (AVR) to the exciter stator. The high efficiency semi-conductors of the AVR ensure positive build-up from initial low levels of residual voltage.

The exciter rotor output is fed to the main rotor through a three-phase full-wave bridge rectifier. The rectifier is protected by a surge suppressor against surges caused, for example, by short circuit or out-of-phase paralleling.

The AS440 will support a range of electronic accessories, including a 'droop' Current Transformer (CT) to permit parallel operation with other ac generators.

MX341 AVR

This sophisticated AVR is incorporated into the Stamford Permanent Magnet Generator (PMG) control system.

The PMG provides power via the AVR to the main exciter, giving a source of constant excitation power independent of generator output. The main exciter output is then fed to the main rotor through a full wave bridge, protected by a surge suppressor.

The AVR has in-built protection against sustained over-excitation, caused by internal or external faults. This de-excites the machine after a minimum of 5 seconds.

An engine relief load acceptance feature can enable full load to be applied to the generator in a single step.

If three-phase sensing is required with the PMG system the MX321 AVR must be used.

We recommend three-phase sensing for applications with greatly unbalanced or highly non-linear loads.

MX321 AVR

The most sophisticated of all our AVRs combines all the features of the MX341 with, additionally, three-phase rms sensing, for improved regulation and performance.

Over voltage protection is built-in and short circuit current level adjustments is an optional facility.

WINDINGS & ELECTRICAL PERFORMANCE

All generator stators are wound to 2/3 pitch. This eliminates triplen (3rd, 9th, 15th ...) harmonics on the voltage waveform and is found to be the optimum design for trouble-free supply of non-linear loads. The 2/3 pitch design avoids excessive neutral currents sometimes seen with higher winding pitches, when in parallel with the mains. A fully connected damper winding reduces oscillations during paralleling. This winding, with the 2/3 pitch and carefully selected pole and tooth designs, ensures very low waveform distortion.

TERMINALS & TERMINAL BOX

Standard generators are 3-phase reconnectable with 12 ends brought out to the terminals, which are mounted on a cover at the non-drive end of the generator. A sheet steel terminal box contains the AVR and provides ample space for the customers' wiring and gland arrangements. It has removable panels for easy access.

SHAFT & KEYS

All generator rotors are dynamically balanced to better than BS6861:Part 1 Grade 2.5 for minimum vibration in operation. Two bearing generators are balanced with a half key.

INSULATION/IMPREGNATION

The insulation system is class 'H'.

All wound components are impregnated with materials and processes designed specifically to provide the high build required for static windings and the high mechanical strength required for rotating components.

QUALITY ASSURANCE

Generators are manufactured using production procedures having a quality assurance level to BS EN ISO 9001.

The stated voltage regulation may not be maintained in the presence of certain radio transmitted signals. Any change in performance will fall within the limits of Criteria 'B' of EN 61000-6-2:2001. At no time will the steady-state voltage regulation exceed 2%.

DE RATES

All values tabulated on page 8 are subject to the following reductions

5% when air inlet filters are fitted.

3% for every 500 metres by which the operating altitude exceeds 1000 metres above mean sea level.

3% for every 5°C by which the operational ambient temperature exceeds 40°C.

Note: Requirement for operating in an ambient exceeding 60°C must be referred to the factory.

NB Continuous development of our products entitles us to change specification details without notice, therefore they must not be regarded as binding.

Front cover drawing typical of product range.

HCI534D/544D



WINDING 311

| | | | | | | | | |
|--|--|--------------------------|--------------------------|---------|------------------------------------|---------|---------|---------|
| CONTROL SYSTEM | SEPARATELY EXCITED BY P.M.G. | | | | | | | |
| A.V.R. | MX321 | MX341 | | | | | | |
| VOLTAGE REGULATION | ± 0.5 % | ± 1.0 % | With 4% ENGINE GOVERNING | | | | | |
| SUSTAINED SHORT CIRCUIT | REFER TO SHORT CIRCUIT DECREMENT CURVES (page 7) | | | | | | | |
| CONTROL SYSTEM | SELF EXCITED | | | | | | | |
| A.V.R. | AS440 | | | | | | | |
| VOLTAGE REGULATION | ± 1.0 % | With 4% ENGINE GOVERNING | | | | | | |
| SUSTAINED SHORT CIRCUIT | SERIES 4 CONTROL DOES NOT SUSTAIN A SHORT CIRCUIT CURRENT | | | | | | | |
| INSULATION SYSTEM | CLASS H | | | | | | | |
| PROTECTION | IP23 | | | | | | | |
| RATED POWER FACTOR | 0.8 | | | | | | | |
| STATOR WINDING | DOUBLE LAYER LAP | | | | | | | |
| WINDING PITCH | TWO THIRDS | | | | | | | |
| WINDING LEADS | 12 | | | | | | | |
| STATOR WDG. RESISTANCE | 0.0049 Ohms PER PHASE AT 22°C SERIES STAR CONNECTED | | | | | | | |
| ROTOR WDG. RESISTANCE | 1.77 Ohms at 22°C | | | | | | | |
| EXCITER STATOR RESISTANCE | 17 Ohms at 22°C | | | | | | | |
| EXCITER ROTOR RESISTANCE | 0.092 Ohms PER PHASE AT 22°C | | | | | | | |
| R.F.I. SUPPRESSION | BS EN 61000-6-2 & BS EN 61000-6-4, VDE 0875G, VDE 0875N. refer to factory for others | | | | | | | |
| WAVEFORM DISTORTION | NO LOAD < 1.5% NON-DISTORTING BALANCED LINEAR LOAD < 5.0% | | | | | | | |
| MAXIMUM OVERSPEED | 2250 Rev/Min | | | | | | | |
| BEARING DRIVE END | BALL. 6220 (ISO) | | | | | | | |
| BEARING NON-DRIVE END | BALL. 6314 (ISO) | | | | | | | |
| | 1 BEARING | | | | 2 BEARING | | | |
| WEIGHT COMP. GENERATOR | 1393 kg | | | | 1395 kg | | | |
| WEIGHT WOUND STATOR | 657 kg | | | | 657 kg | | | |
| WEIGHT WOUND ROTOR | 563 kg | | | | 535 kg | | | |
| WR ² INERTIA | 8.0068 kgm ² | | | | 7.7289 kgm ² | | | |
| SHIPPING WEIGHTS in a crate | 1485 kg | | | | 1485 kg | | | |
| PACKING CRATE SIZE | 166 x 87 x 124(cm) | | | | 166 x 87 x 124(cm) | | | |
| | 50 Hz | | | | 60 Hz | | | |
| TELEPHONE INTERFERENCE | THF<2% | | | | TIF<50 | | | |
| COOLING AIR | 1.035 m ³ /sec 2202 cfm | | | | 1.312 m ³ /sec 2780 cfm | | | |
| VOLTAGE SERIES STAR | 380/220 | 400/231 | 415/240 | 440/254 | 416/240 | 440/254 | 460/266 | 480/277 |
| VOLTAGE PARALLEL STAR | 190/110 | 200/115 | 208/120 | 220/127 | 208/120 | 220/127 | 230/133 | 240/138 |
| VOLTAGE SERIES DELTA | 220/110 | 230/115 | 240/120 | 254/127 | 240/120 | 254/127 | 266/133 | 277/138 |
| KVA BASE RATING FOR REACTANCE VALUES | 500 | 550 | 500 | 500 | 575 | 594 | 625 | 644 |
| X _d DIR. AXIS SYNCHRONOUS | 3.02 | 2.99 | 2.53 | 2.25 | 3.52 | 3.25 | 3.13 | 2.96 |
| X' _d DIR. AXIS TRANSIENT | 0.16 | 0.15 | 0.13 | 0.12 | 0.17 | 0.16 | 0.15 | 0.14 |
| X'' _d DIR. AXIS SUBTRANSIENT | 0.11 | 0.11 | 0.09 | 0.08 | 0.12 | 0.11 | 0.11 | 0.10 |
| X _q QUAD. AXIS REACTANCE | 2.48 | 2.46 | 2.08 | 1.85 | 2.87 | 2.65 | 2.55 | 2.41 |
| X'' _q QUAD. AXIS SUBTRANSIENT | 0.27 | 0.28 | 0.23 | 0.20 | 0.31 | 0.29 | 0.28 | 0.26 |
| X _L LEAKAGE REACTANCE | 0.05 | 0.04 | 0.04 | 0.04 | 0.06 | 0.06 | 0.05 | 0.05 |
| X ₂ NEGATIVE SEQUENCE | 0.19 | 0.19 | 0.16 | 0.14 | 0.22 | 0.20 | 0.20 | 0.19 |
| X ₀ ZERO SEQUENCE | 0.10 | 0.10 | 0.08 | 0.07 | 0.10 | 0.09 | 0.09 | 0.08 |
| REACTANCES ARE SATURATED VALUES ARE PER UNIT AT RATING AND VOLTAGE INDICATED | | | | | | | | |
| T' _d TRANSIENT TIME CONST. | 0.08s | | | | | | | |
| T'' _d SUB-TRANSTIME CONST. | 0.012s | | | | | | | |
| T' _{do} O.C. FIELD TIME CONST. | 2.2s | | | | | | | |
| T _a ARMATURE TIME CONST. | 0.018s | | | | | | | |
| SHORT CIRCUIT RATIO | 1/X _d | | | | | | | |

50
Hz

HCI534D/544D

STAMFORD

Winding 311

THREE PHASE EFFICIENCY CURVES

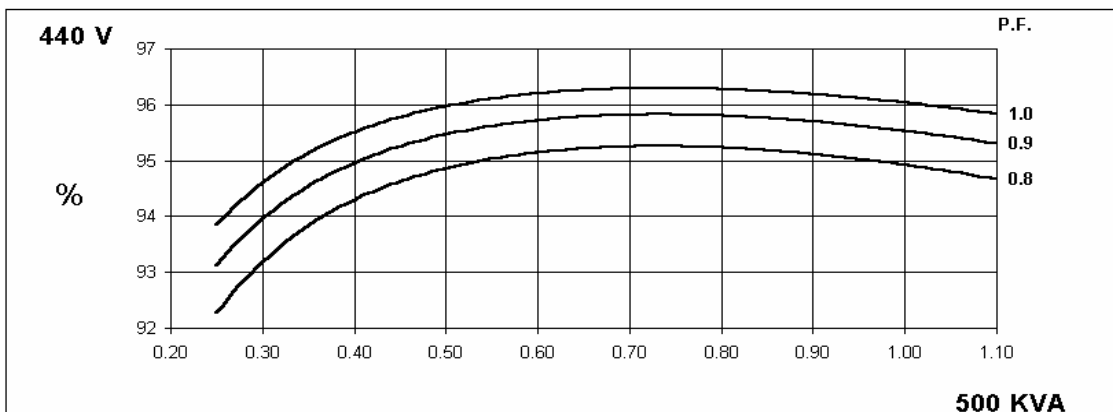
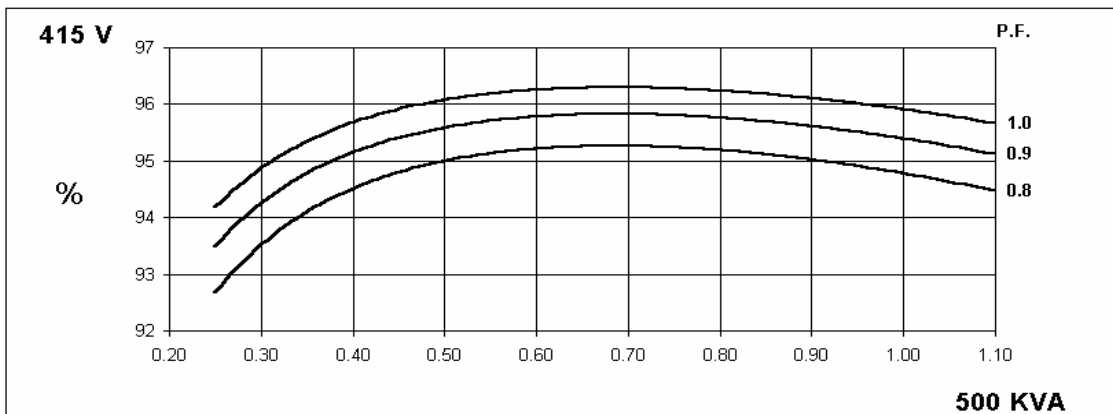
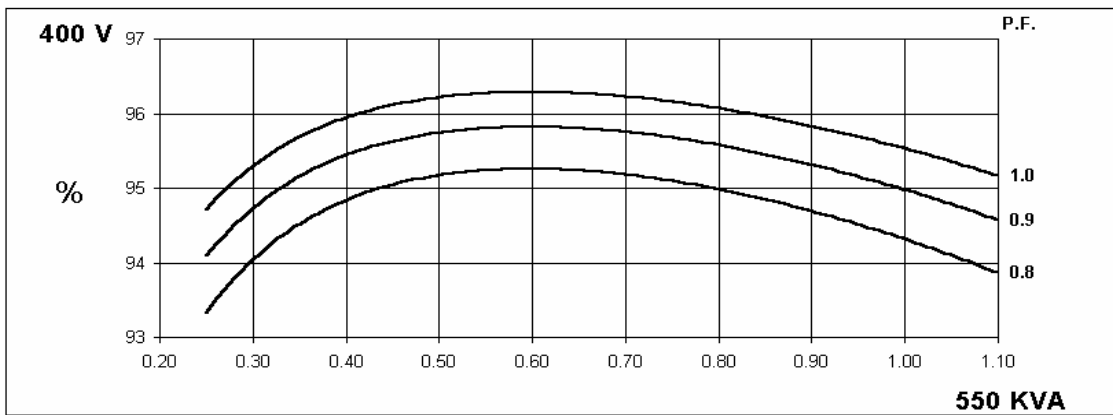
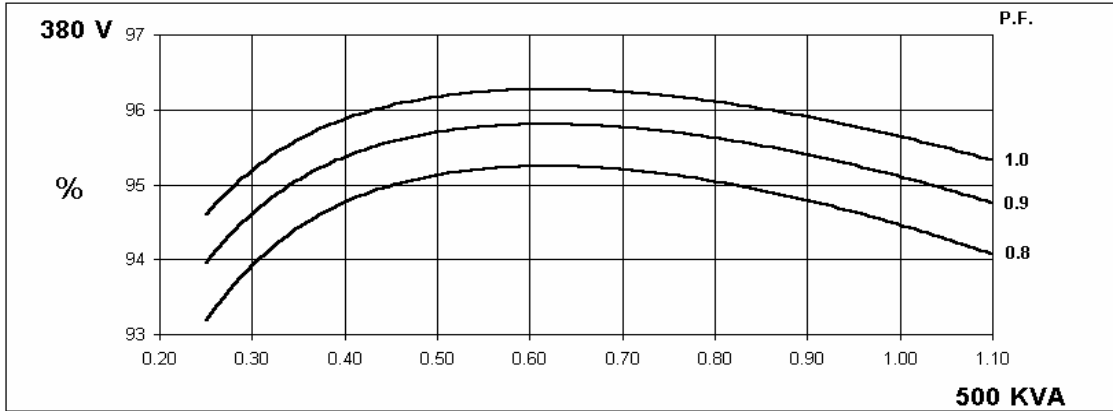

60
Hz

HCI534D/544D

STAMFORD

Winding 311

THREE PHASE EFFICIENCY CURVES

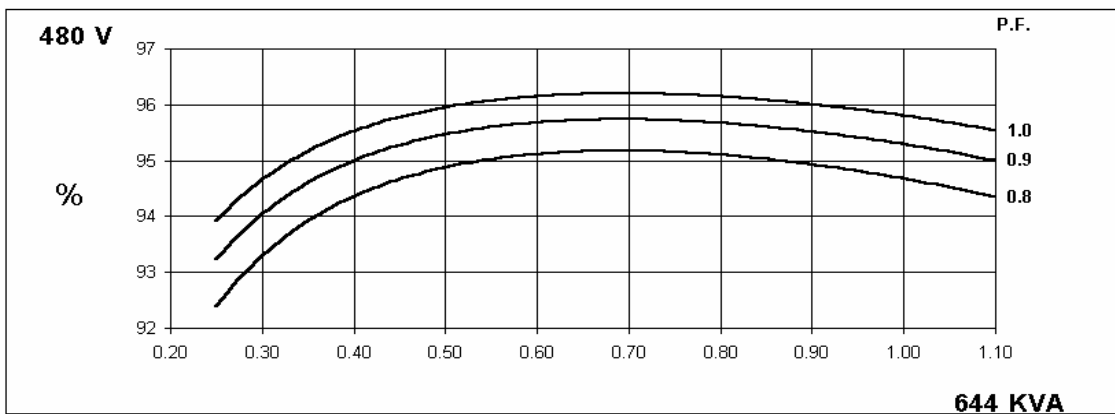
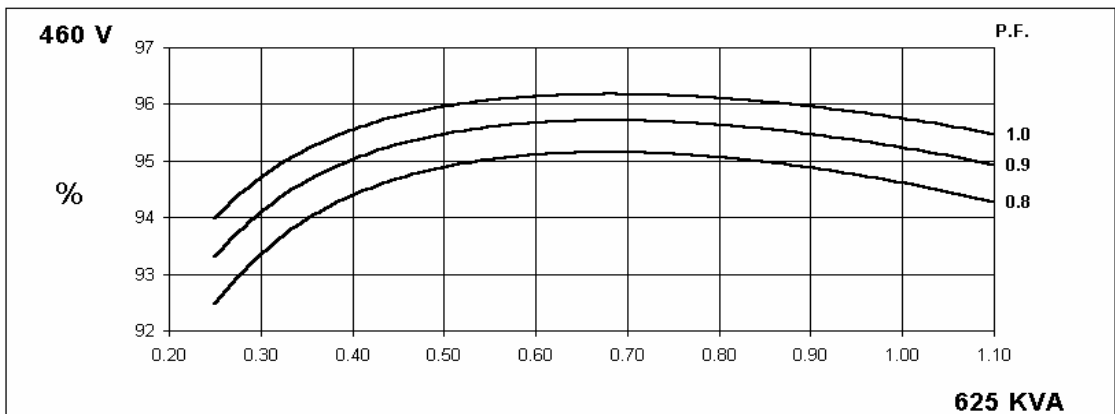
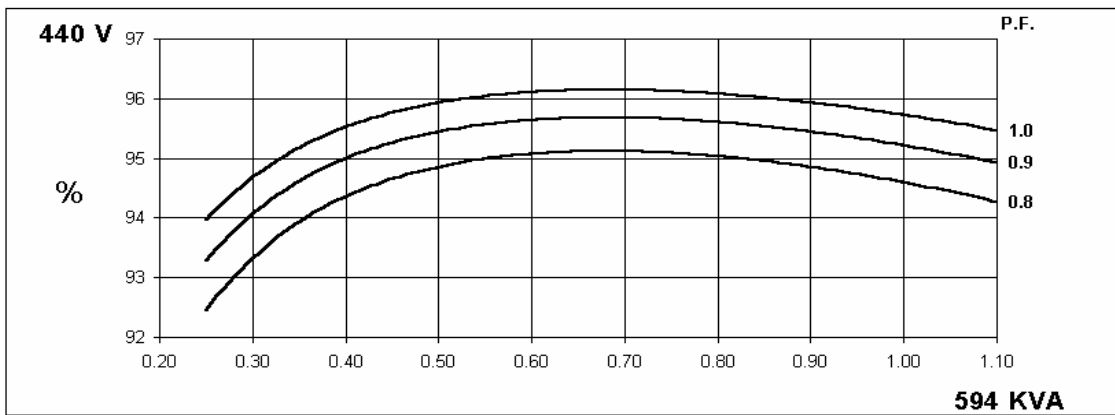
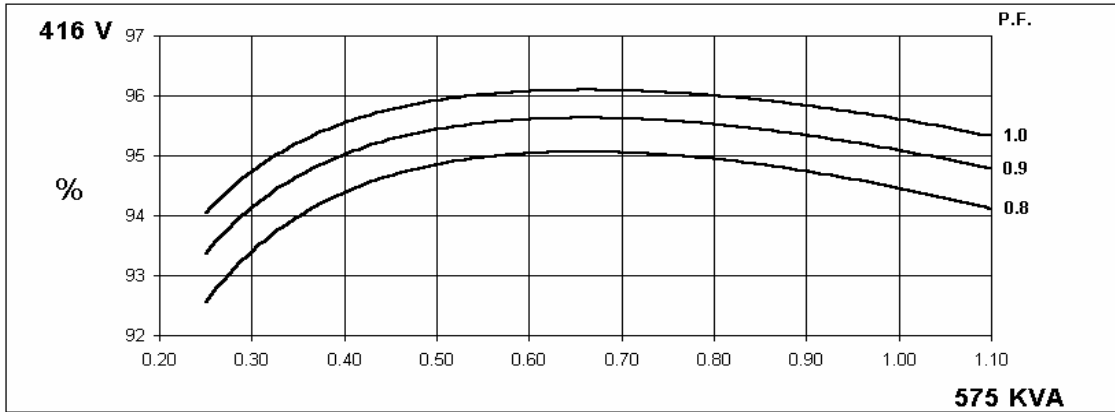

Locked Rotor Motor Starting Curve

50
Hz

MX

SX

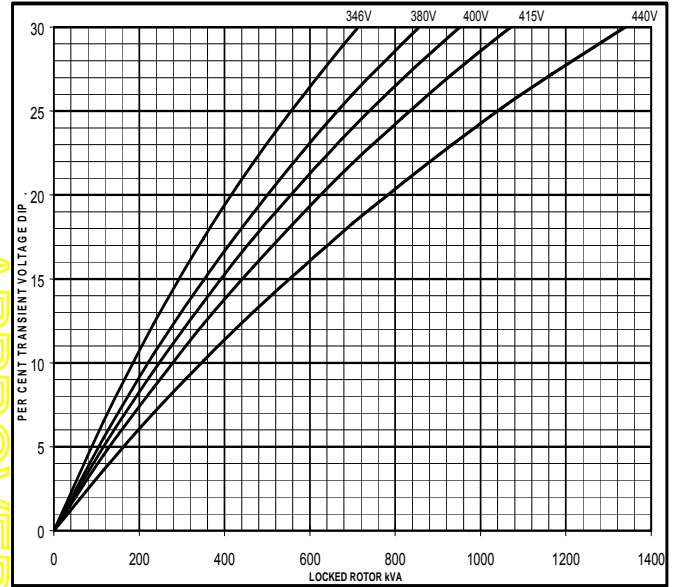
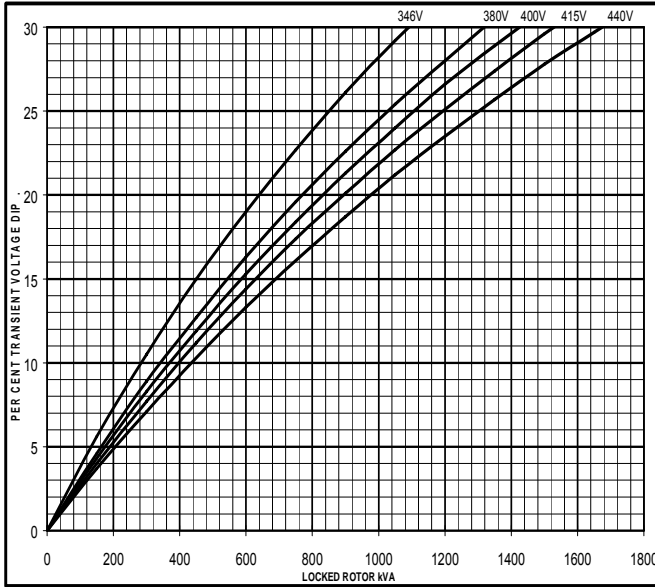

60
Hz

MX

SX

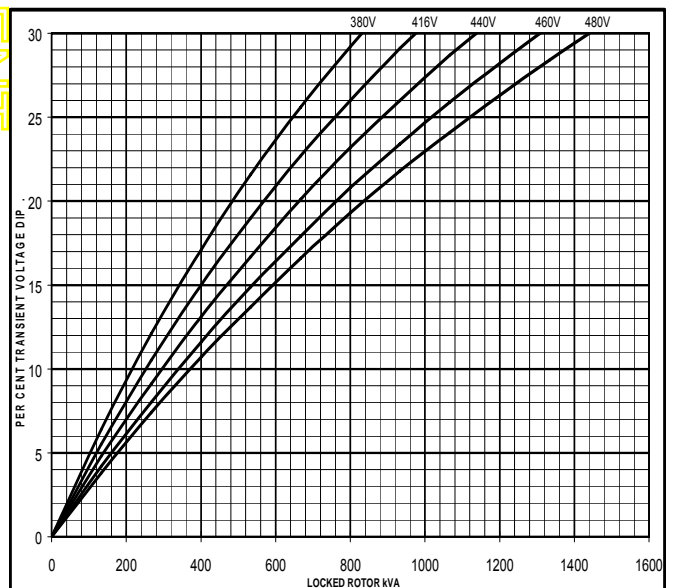
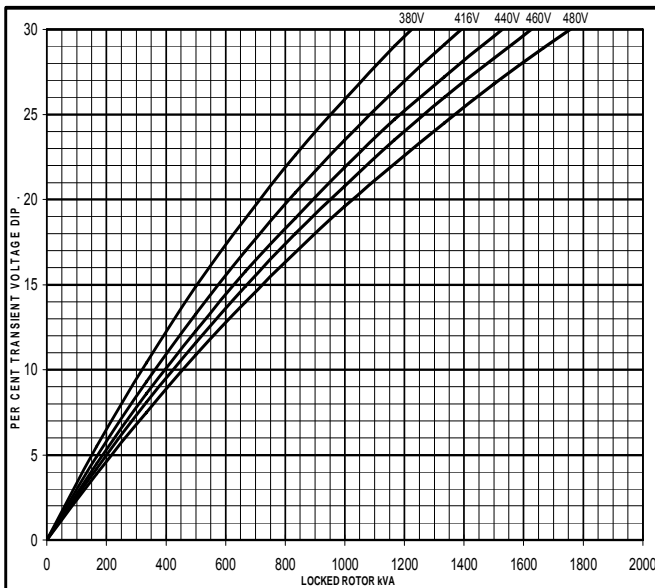

APPROVED DOCUMENT

**Three-phase Short Circuit Decrement Curve. No-load Excitation at Rated Speed
Based on star (wye) connection.**

50
Hz

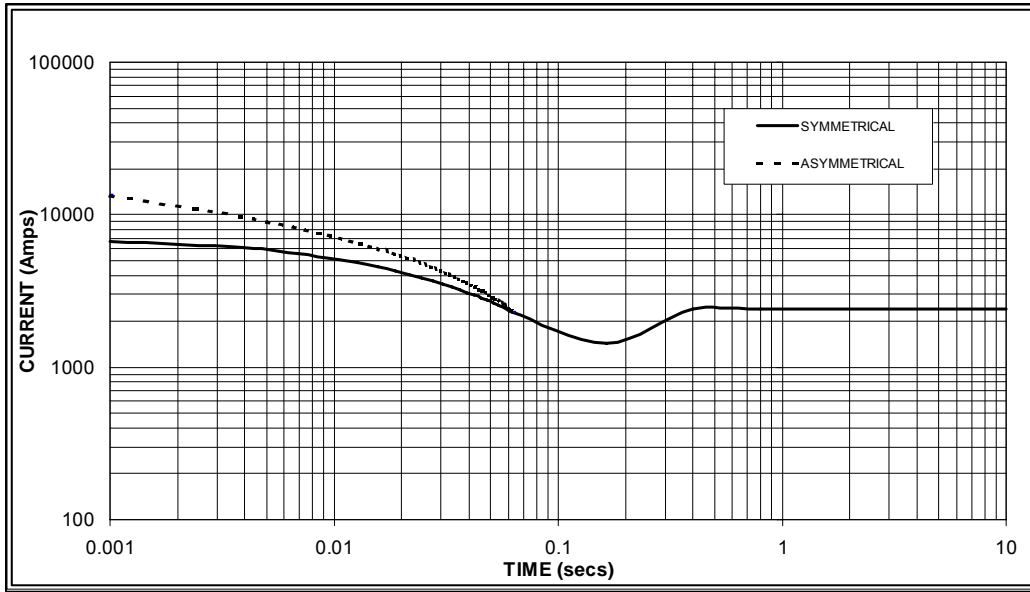

Sustained Short Circuit = 2,400 Amps



60
Hz

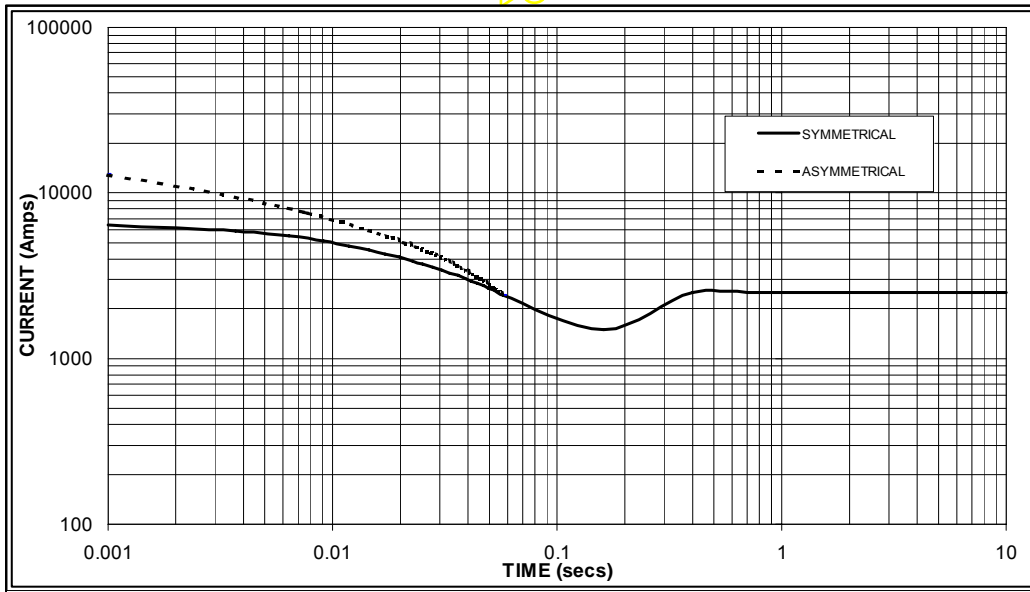

Sustained Short Circuit = 2,500 Amps

Note 1

The following multiplication factors should be used to adjust the values from curve between time 0.001 seconds and the minimum current point in respect of nominal operating voltage :

| 50Hz | | 60Hz | |
|---------|--------|---------|--------|
| Voltage | Factor | Voltage | Factor |
| 380v | X 1.00 | 416v | X 1.00 |
| 400v | X 1.06 | 440v | X 1.06 |
| 415v | X 1.09 | 460v | X 1.12 |
| 440v | X 1.12 | 480v | X 1.20 |

The sustained current value is constant irrespective of voltage level

Note 2

The following multiplication factor should be used to convert the values calculated in accordance with NOTE 1 to those applicable to the various types of short circuit :

| | 3-phase | 2-phase L-L | 1-phase L-N |
|-------------------------|---------|-------------|-------------|
| Instantaneous | x 1.00 | x 0.87 | x 1.30 |
| Minimum | x 1.00 | x 1.80 | x 3.20 |
| Sustained | x 1.00 | x 1.50 | x 2.50 |
| Max. sustained duration | 10 sec. | 5 sec. | 2 sec. |

All other times are unchanged

Note 3

Curves are drawn for Star (Wye) connected machines. For other connections the following multipliers should be applied to current values as shown :

Parallel Star = Curve current value X 2

Series Delta = Curve current value X 1.732

HCI534D/544D

STAMFORD

Winding 311 0.8 Power Factor

RATINGS

| Class - Temp Rise | Cont. F - 105/40°C | | | | Cont. H - 125/40°C | | | | Standby - 150/40°C | | | | Standby - 163/27°C | | | | |
|-------------------|--------------------|------|------|------|--------------------|------|------|------|--------------------|------|------|------|--------------------|------|------|------|-----|
| 50 Hz | Series Star (V) | 380 | 400 | 415 | 440 | 380 | 400 | 415 | 440 | 380 | 400 | 415 | 440 | 380 | 400 | 415 | 440 |
| | Parallel Star (V) | 190 | 200 | 208 | 220 | 190 | 200 | 208 | 220 | 190 | 200 | 208 | 220 | 190 | 200 | 208 | 220 |
| | Series Delta (V) | 220 | 230 | 240 | 254 | 220 | 230 | 240 | 254 | 220 | 230 | 240 | 254 | 220 | 230 | 240 | 254 |
| kVA | 450 | 495 | 450 | 450 | 500 | 550 | 500 | 500 | 515 | 575 | 515 | 515 | 550 | 590 | 550 | 530 | |
| kW | 360 | 396 | 360 | 360 | 400 | 440 | 400 | 400 | 412 | 460 | 412 | 412 | 440 | 472 | 440 | 424 | |
| Efficiency (%) | 94.8 | 94.7 | 95.0 | 95.1 | 94.5 | 94.3 | 94.8 | 94.9 | 94.4 | 94.1 | 94.7 | 94.9 | 94.1 | 94.0 | 94.5 | 94.8 | |
| kW Input | 380 | 418 | 379 | 379 | 423 | 467 | 422 | 421 | 436 | 489 | 435 | 434 | 468 | 502 | 466 | 447 | |

| | | | | | | | | | | | | | | | | | |
|----------------|-------------------|------|------|------|------|------|------|------|------|------|------|------|------|------|------|------|-----|
| 60 Hz | Series Star (V) | 416 | 440 | 460 | 480 | 416 | 440 | 460 | 480 | 416 | 440 | 460 | 480 | 416 | 440 | 460 | 480 |
| | Parallel Star (V) | 208 | 220 | 230 | 240 | 208 | 220 | 230 | 240 | 208 | 220 | 230 | 240 | 208 | 220 | 230 | 240 |
| | Delta (V) | 240 | 254 | 266 | 277 | 240 | 254 | 266 | 277 | 240 | 254 | 266 | 277 | 240 | 254 | 266 | 277 |
| kVA | 519 | 538 | 563 | 588 | 575 | 594 | 625 | 644 | 588 | 625 | 655 | 675 | 606 | 644 | 673 | 694 | |
| kW | 415 | 430 | 450 | 470 | 460 | 475 | 500 | 515 | 470 | 500 | 524 | 540 | 485 | 515 | 538 | 555 | |
| Efficiency (%) | 94.7 | 94.8 | 94.9 | 94.9 | 94.5 | 94.6 | 94.6 | 94.7 | 94.4 | 94.4 | 94.5 | 94.5 | 94.3 | 94.3 | 94.4 | 94.4 | |
| kW Input | 438 | 454 | 475 | 496 | 487 | 502 | 529 | 544 | 498 | 530 | 554 | 571 | 514 | 546 | 570 | 588 | |

DIMENSIONS

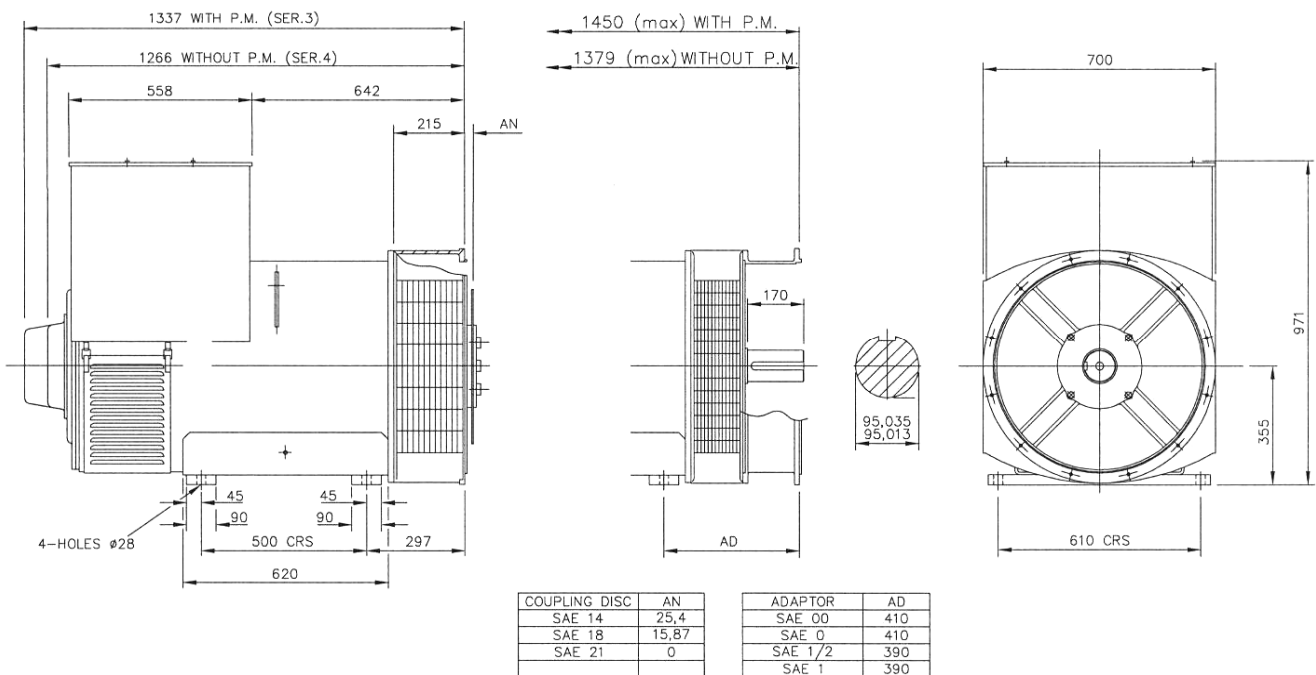

APPROVED DOCUMENT

STAMFORD

Head Office Address:
Barnack Road, Stamford
Lincolnshire, PE9 2NB
United Kingdom
Tel: +44 (0) 1780 484000
Fax: +44 (0) 1780 484100

www.cumminsgeneratortechnologies.com

Copyright 2010, Cummins Generator Technologies Ltd, All Rights Reserved
Stamford and AvK are registered trade marks of Cummins Generator Technologies Ltd
Cummins and the Cummins logo are registered trade marks of Cummins Inc.

STAMFORD®

HCI534C/544C - Winding 17

Technical  Data Sheet

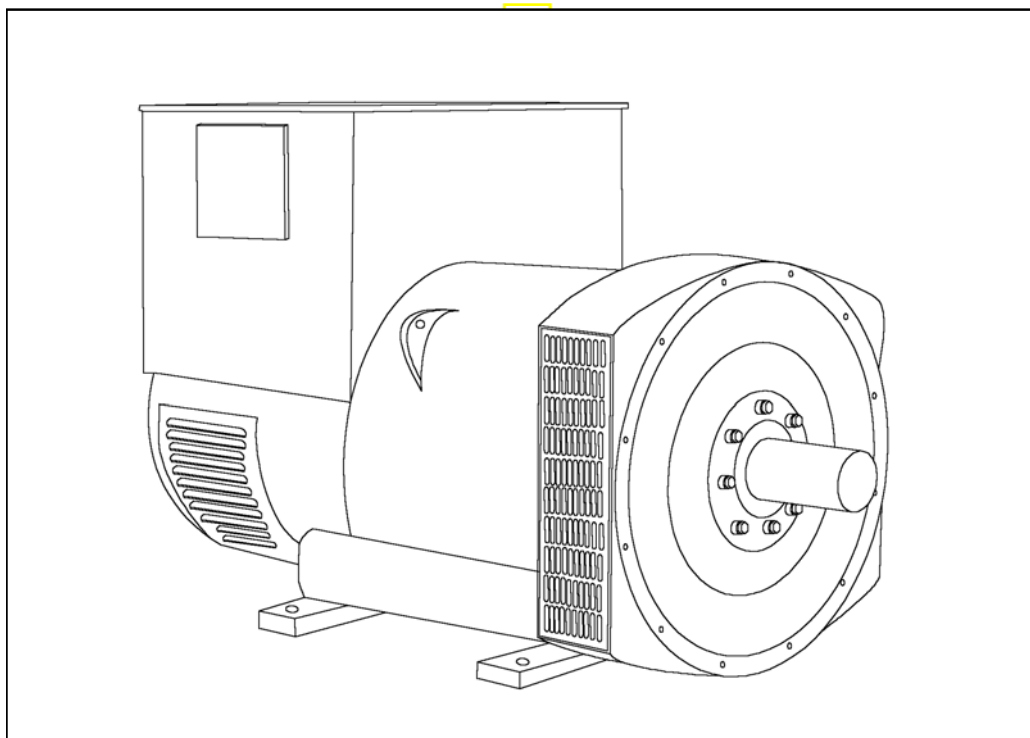

HCI534C/544C

SPECIFICATIONS & OPTIONS

STAMFORD

STANDARDS

Stamford industrial generators meet the requirements of BS EN 60034 and the relevant section of other international standards such as BS5000, VDE 0530, NEMA MG1-32, IEC34, CSA C22.2-100, AS1359. Other standards and certifications can be considered on request.

VOLTAGE REGULATORS

AS440 AVR - STANDARD

With this self-excited system the main stator provides power via the Automatic Voltage Regulator (AVR) to the exciter stator. The high efficiency semi-conductors of the AVR ensure positive build-up from initial low levels of residual voltage.

The exciter rotor output is fed to the main rotor through a three-phase full-wave bridge rectifier. The rectifier is protected by a surge suppressor against surges caused, for example, by short circuit or out-of-phase paralleling.

The AS440 will support a range of electronic accessories, including a 'droop' Current Transformer (CT) to permit parallel operation with other ac generators.

MX341 AVR

This sophisticated AVR is incorporated into the Stamford Permanent Magnet Generator (PMG) control system.

The PMG provides power via the AVR to the main exciter, giving a source of constant excitation power independent of generator output. The main exciter output is then fed to the main rotor, through a full wave bridge, protected by a surge suppressor. The AVR has in-built protection against sustained over-excitation, caused by internal or external faults. This de-excites the machine after a minimum of 5 seconds.

An engine relief load acceptance feature can enable full load to be applied to the generator in a single step.

If three-phase sensing is required with the PMG system the MX321 AVR must be used.

We recommend three-phase sensing for applications with greatly unbalanced or highly non-linear loads.

MX321 AVR

The most sophisticated of all our AVRs combines all the features of the MX341 with, additionally, three-phase rms sensing, for improved regulation and performance.

Over voltage protection is built-in and short circuit current level adjustments is an optional facility.

WINDINGS & ELECTRICAL PERFORMANCE

All generator stators are wound to 2/3 pitch. This eliminates triplen (3rd, 9th, 15th ...) harmonics on the voltage waveform and is found to be the optimum design for trouble-free supply of non-linear loads. The 2/3 pitch design avoids excessive neutral currents sometimes seen with higher winding pitches, when in parallel with the mains. A fully connected damper winding reduces oscillations during paralleling. This winding, with the 2/3 pitch and carefully selected pole and tooth designs, ensures very low waveform distortion.

TERMINALS & TERMINAL BOX

Standard generators are 3-phase reconnectable with 12 ends brought out to the terminals, which are mounted on a cover at the non-drive end of the generator. A sheet steel terminal box contains the AVR and provides ample space for the customers' wiring and gland arrangements. It has removable panels for easy access.

SHAFT & KEYS

All generator rotors are dynamically balanced to better than BS6861:Part 1 Grade 2.5 for minimum vibration in operation. Two bearing generators are balanced with a half key.

INSULATION/IMPREGNATION

The insulation system is class 'H'.

All wound components are impregnated with materials and processes designed specifically to provide the high build required for static windings and the high mechanical strength required for rotating components.

QUALITY ASSURANCE

Generators are manufactured using production procedures having a quality assurance level to BS EN ISO 9001.

The stated voltage regulation may not be maintained in the presence of certain radio transmitted signals. Any change in performance will fall within the limits of Criteria 'B' of EN 61000-6-2:2001. At no time will the steady-state voltage regulation exceed 2%.

DE RATES

All values tabulated on page 6 are subject to the following reductions

5% when air inlet filters are fitted.

3% for every 500 metres by which the operating altitude exceeds 1000 metres above mean sea level.

3% for every 5 C by which the operational ambient temperature exceeds 40 C.

Note: Requirement for operating in an ambient exceeding 60 C must be referred to the factory.

NB Continuous development of our products entitles us to change specification details without notice, therefore they must not be regarded as binding.

Front cover drawing typical of product range.

APPROVED DOCUMENT

HCI534C/544C

STAMFORD

WINDING 17

| | | | |
|--|--|---|--------------------------|
| CONTROL SYSTEM | SEPARATELY EXCITED BY P.M.G. | | |
| A.V.R. | MX321 | MX341 | |
| VOLTAGE REGULATION | ± 0.5 % | ± 1.0 % | With 4% ENGINE GOVERNING |
| SUSTAINED SHORT CIRCUIT | REFER TO SHORT CIRCUIT DECREMENT CURVES (page 5) | | |
| CONTROL SYSTEM | SELF EXCITED | | |
| A.V.R. | AS440 | | |
| VOLTAGE REGULATION | ± 1.0 % | | With 4% ENGINE GOVERNING |
| SUSTAINED SHORT CIRCUIT | WILL NOT SUSTAIN A SHORT CIRCUIT | | |
| INSULATION SYSTEM | CLASS H | | |
| PROTECTION | IP23 | | |
| RATED POWER FACTOR | 0.8 | | |
| STATOR WINDING | DOUBLE LAYER LAP | | |
| WINDING PITCH | TWO THIRDS | | |
| WINDING LEADS | 12 | | |
| STATOR WDG. RESISTANCE | 0.0105 Ohms PER PHASE AT 22°C SERIES STAR CONNECTED | | |
| ROTOR WDG. RESISTANCE | 1.55 Ohms at 22°C | | |
| EXCITER STATOR RESISTANCE | 17 Ohms at 22°C | | |
| EXCITER ROTOR RESISTANCE | 0.092 Ohms PER PHASE AT 22°C | | |
| R.F.I. SUPPRESSION | BS EN 61000-6-2 & BS EN 61000-6-4, VDE 0875G, VDE 0875N. refer to factory for others | | |
| WAVEFORM DISTORTION | NO LOAD < 1.5% NON-DISTORTING BALANCED LINEAR LOAD < 5.0% | | |
| MAXIMUM OVERSPEED | 2250 Rev/Min | | |
| BEARING DRIVE END | BALL. 6220 (ISO) | | |
| BEARING NON-DRIVE END | BALL. 6314 (ISO) | | |
| | 1 BEARING | 2 BEARING | |
| WEIGHT COMP. GENERATOR | 1263 kg | 1275 kg | |
| WEIGHT WOUND STATOR | 584 kg | 584 kg | |
| WEIGHT WOUND ROTOR | 502 kg | 473 kg | |
| WR ² INERTIA | 6.8928 kgm ² | 6.6149 kgm ² | |
| SHIPPING WEIGHTS in a crate | 1355 kg | 1395 kg | |
| PACKING CRATE SIZE | 166 x 87 x 124 (cm) | 166 x 87 x 124 (cm) | |
| TELEPHONE INTERFERENCE | THF<2% | TIF<50 | |
| COOLING AIR | 1.312 m ³ /sec 2780 cfm | | |
| VOLTAGE SERIES STAR | 600V | | |
| VOLTAGE PARALLEL STAR | 300V | | |
| VOLTAGE SERIES DELTA | 346V | | |
| KVA BASE RATING FOR REACTANCE VALUES | 563 | | |
| X _d DIR. AXIS SYNCHRONOUS | 2.95 | | |
| X' _d DIR. AXIS TRANSIENT | 0.13 | | |
| X'' _d DIR. AXIS SUBTRANSIENT | 0.10 | | |
| X _q QUAD. AXIS REACTANCE | 2.33 | | |
| X'' _q QUAD. AXIS SUBTRANSIENT | 0.26 | | |
| X _L LEAKAGE REACTANCE | 0.06 | | |
| X ₂ NEGATIVE SEQUENCE | 0.18 | | |
| X ₀ ZERO SEQUENCE | 0.08 | | |
| REACTANCES ARE SATURATED | | VALUES ARE PER UNIT AT RATING AND VOLTAGE INDICATED | |
| T' _d TRANSIENT TIME CONST. | 0.08 s | | |
| T'' _d SUB-TRANSTIME CONST. | 0.012 s | | |
| T' _{do} O.C. FIELD TIME CONST. | 2 s | | |
| T _a ARMATURE TIME CONST. | 0.017 s | | |
| SHORT CIRCUIT RATIO | 1/X _d | | |

HC1534C/544C

STAMFORD

Winding 17

SX

Locked Rotor Motor Starting Curves

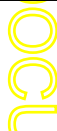
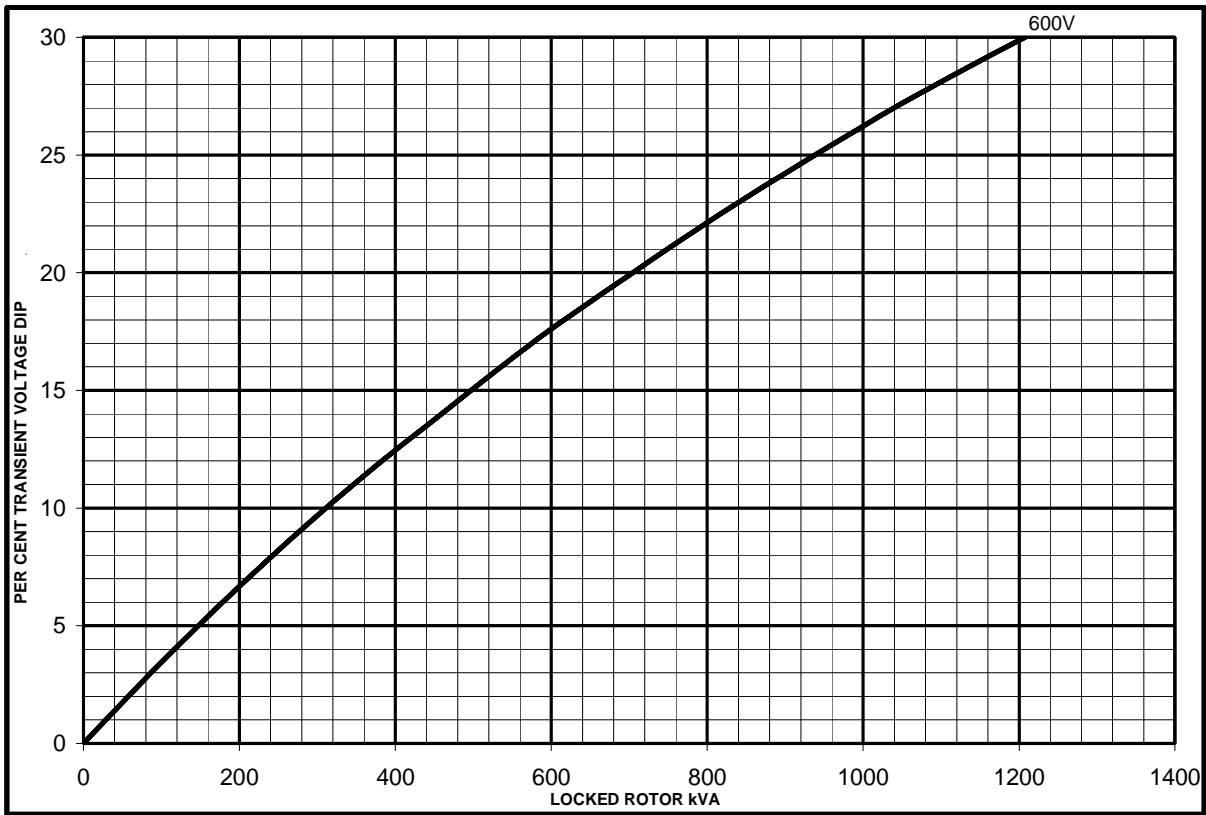

MX

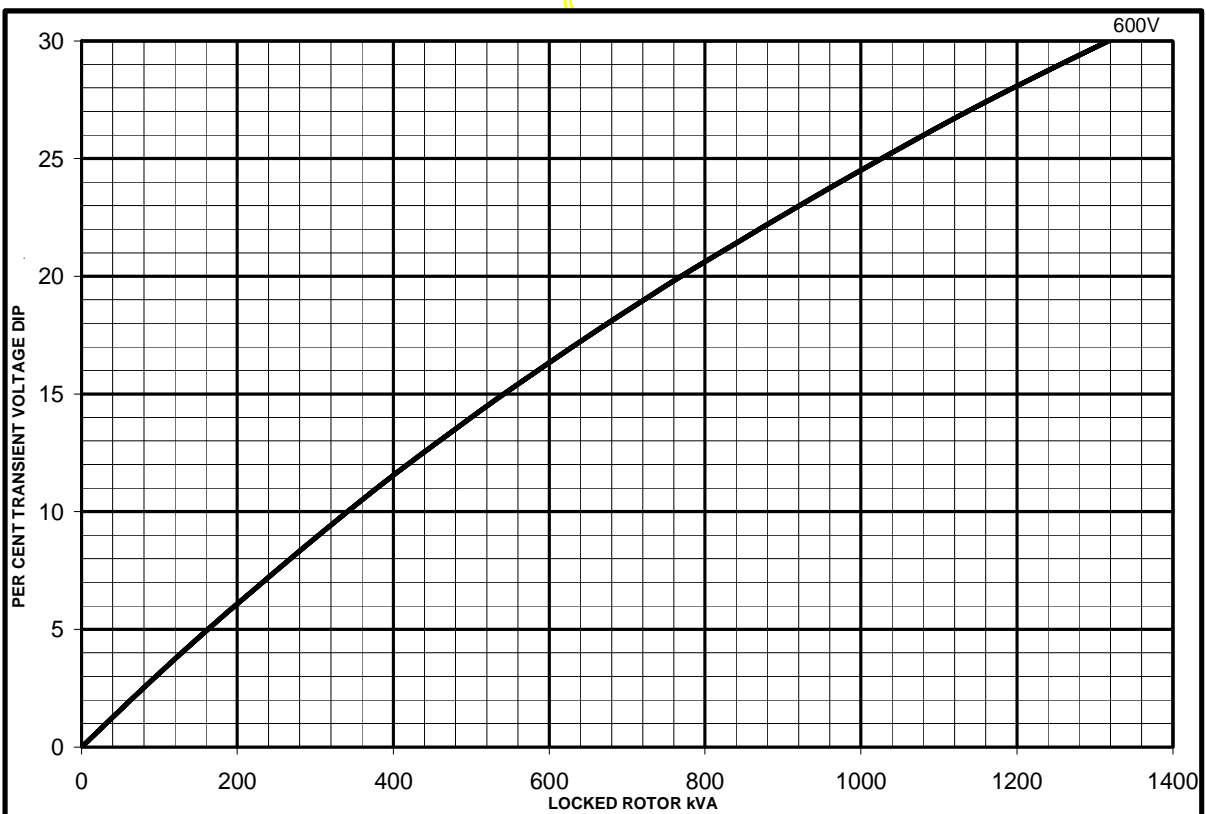

HCI534C/544C
Winding 17

STAMFORD

THREE PHASE EFFICIENCY CURVES

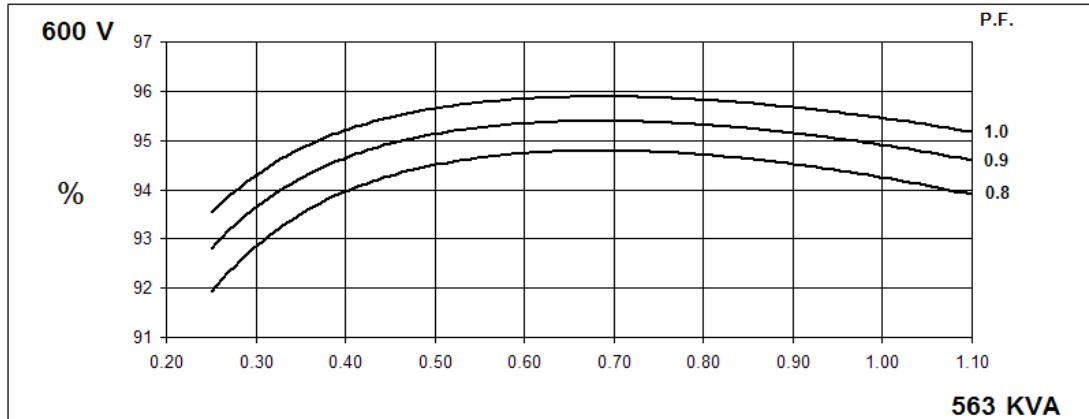

Three-phase Short Circuit Decrement Curve. No-load Excitation at Rated Speed Based on star (wye) connection.

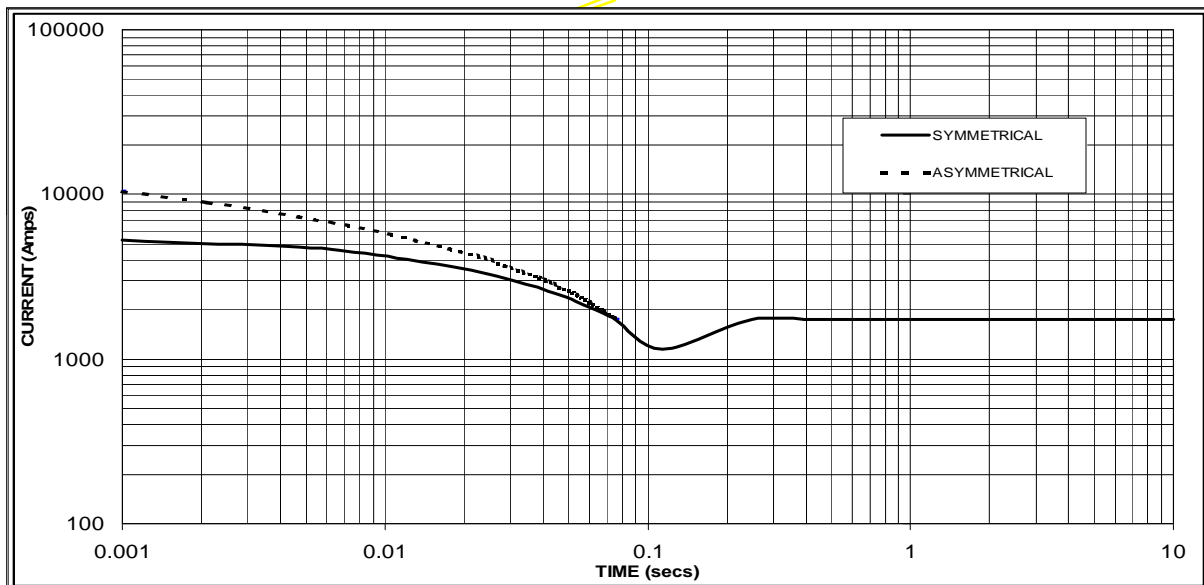

Sustained Short Circuit = 1750 Amps

Note

The following multiplication factor should be used to convert the values from curve for the various types of short circuit :

| | 3-phase | 2-phase L-L | 1-phase L-N |
|-------------------------|---------|-------------|-------------|
| Instantaneous | x 1.00 | x 0.87 | x 1.30 |
| Minimum | x 1.00 | x 1.80 | x 3.20 |
| Sustained | x 1.00 | x 1.50 | x 2.50 |
| Max. sustained duration | 10 sec. | 5 sec. | 2 sec. |

All other times are unchanged

HCI534C/544C
Winding 17 / 0.8 Power Factor

STAMFORD

60Hz

RATINGS

| Class - Temp Rise | Cont. F - 105/40°C | Cont. H - 125/40°C | Standby - 150/40°C | Standby - 163/27°C |
|-------------------|--------------------|--------------------|--------------------|--------------------|
| Series Star (V) | 600 | 600 | 600 | 600 |
| Parallel Star (V) | 300 | 300 | 300 | 300 |
| Series Delta (V) | 346 | 346 | 346 | 346 |
| kVA | 515 | 563 | 595 | 615 |
| kW | 412 | 450 | 476 | 492 |
| Efficiency (%) | 94.5 | 94.2 | 94.1 | 93.9 |
| kW Input | 436 | 478 | 506 | 524 |

APPROVED

DIMENSIONS

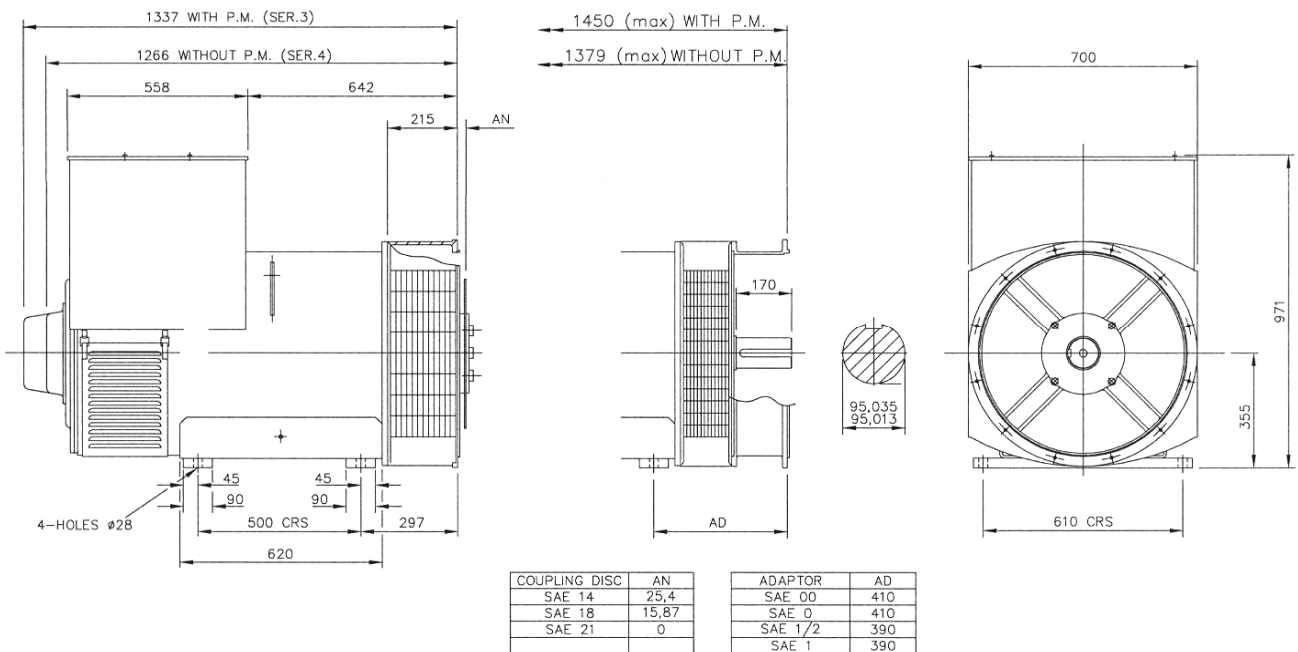

APPROVED DOCUMENT

STAMFORD

Head Office Address:
Barnack Road, Stamford
Lincolnshire, PE9 2NB
United Kingdom
Tel: +44 (0) 1780 484000
Fax: +44 (0) 1780 484100

www.cumminsgeneratortechnologies.com

Copyright 2010, Cummins Generator Technologies Ltd, All Rights Reserved
Stamford and AvK are registered trade marks of Cummins Generator Technologies Ltd
Cummins and the Cummins logo are registered trade marks of Cummins Inc.

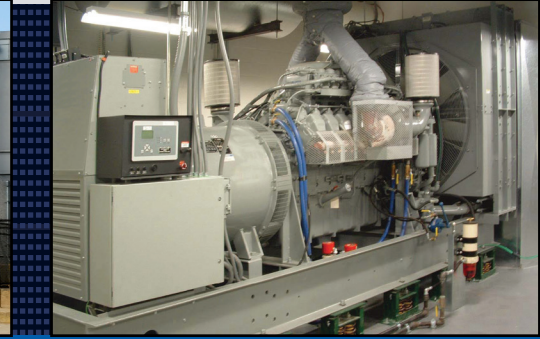

A highly advanced integrated genset control system, this device provides genset control, transfer switch control, metering, protection, and programmable logic in a simple, easy-to-use, reliable, rugged, and cost effective package.

FEATURES

- Generator metering (includes three-phase mains)
- Engine and generator protection: 27, 32R, 40Q, 59, 810/U
- Optional enhanced generator protection: 47, 51, 78, and 81ROCOF
- Load sharing and generator sequencing (via LSM-200 Load Share Module)
- Var sharing over Ethernet (via LSM-200)
- BESTCOMSP^{Plus}® Software
 - Programming and setup
 - Intuitive and powerful
 - Remote control and monitoring
 - Programmable logic
 - USB communications
- Automatic transfer switch control
- Automatic synchronizer (optional)
- Exercise timer
- SAE J1939 engine ECU communications
- Automatic generator configuration detection
- Expandable functionality via add-on modules
 - [LSM-200 Load Share Module](#)
 - [CEM-200 Contact Expansion Module](#)
 - [AEM-200 Analog Expansion Module](#)
- Multilingual capability
- Remote communications to Basler's RDP-110 (remote display panel)
- Sixteen programmable contact inputs
- Up to 15 contact outputs: 3 contacts rated for 30 Adc and up to 12 programmable contacts rated for 2 Adc

BENEFITS

- Provides integrated engine-genset control, protection, and metering in a single package.
- The Offline Simulator, provided in BESTlogic™*Plus*, helps test and troubleshoot logic without the need for expensive hardware.
- Flexible programmable logic and programmable I/O make it easy to expand the DGC-200's inputs and outputs with the CEM-200 (Contact Expansion Module) and the AEM-200 (Analog Expansion Module). This saves time and money by eliminating unnecessary external PLCs and control relaying.

Visit www.basler.com
FOR ADDITIONAL INFORMATION.

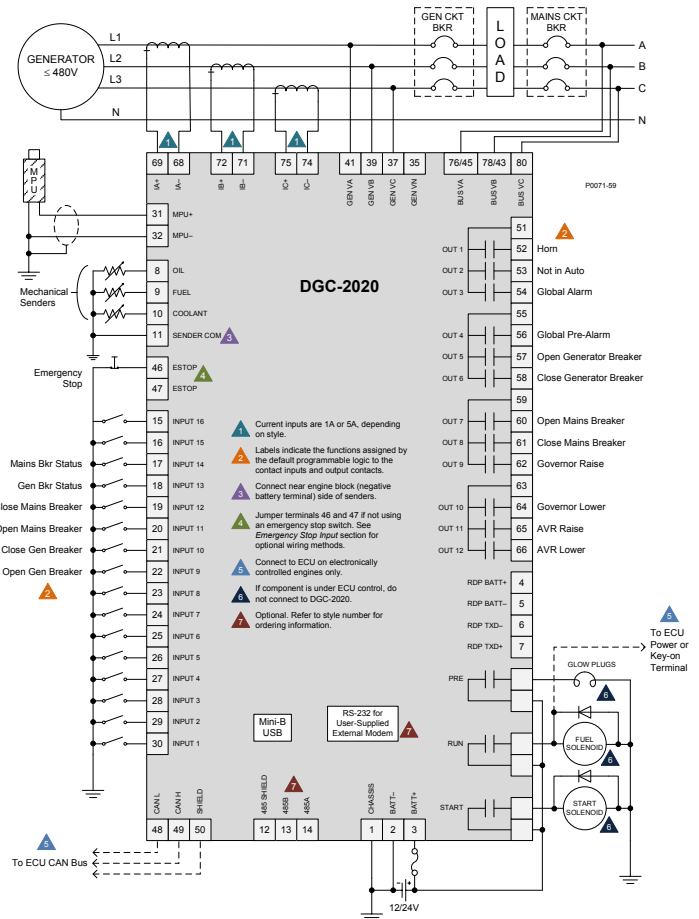

Figure 1 - DGC-200 Connection Diagram for a Typical Application

SPECIFICATIONS

Power Supply

| | |
|-----------------------|--|
| Nominal: | 12 or 24 Vdc |
| Range: | 6 to 32 Vdc |
| Battery Ride Through: | Starting at 10 Vdc, withstands cranking ride-through down to 0 V for 50 ms |

Power Consumption

| | |
|--------------------------|--------|
| Sleep Mode: | 5 W |
| Normal Operational Mode: | 7.9 W |
| Maximum: | 14.2 W |

Current Sensing

| | |
|--------------|---|
| 1 A Sensing: | 0.02 to 1.0 Aac, continuous 2 Aac for 1 second |
| 5 A Sensing: | 0.1 to 5.0 Aac, continuous 10 Aac for 1 second |
| Burden: | 1 VA |

Voltage Sensing

| | |
|--------------------|--|
| Range: | 12 to 576 Vrms L-L |
| Frequency Range: | 10 to 72 Hz for 50/60 Hz style, 10 to 480 Hz for 400 Hz style |
| Burden: | 1 VA |
| One-second Rating: | 720 Vrms |

Contact Sensing

| | |
|----------------------|---|
| Contact Inputs (16): | Accepts normally open (N.O.), Dry Contacts, programmable |
| Emergency Stop: | Normally closed (N.C.), Dry Contact |

Engine Speed Sensing

| | |
|--------------------------|-----------------|
| Magnetic Pickup: | |
| Voltage Range: | 6 to 70 Vpp |
| Frequency Range: | 32 to 10,000 Hz |
| Generator Frequency: | |
| Generator Voltage Range: | 12 to 576 Vrms |
| Via ECU over J1939 | |

Resistive Senders

| | |
|----------------------|-----------------------|
| Fuel Level Sender: | 0 to 250 Ω nominal |
| Coolant Temp Sender: | 10 to 2,750 Ω nominal |
| Oil Pressure Sender: | 0 to 250 Ω nominal |

Output Contacts

| | |
|--|--|
| Fuel Solenoid, Engine Crank, Pre-Start Relays Rating: | 30 Adc at 28 Vdc- make, break, and carry |
| Programmable Relays: Rating: | Up to 12 2 Adc at 28 Vdc- make, break, and carry |

Protection

| | |
|------------|--|
| Generator: | 27, 32R, 40Q, 59, 81O/U (standard) 47, 51, 78, 81 ROCOF (optional) |
| Engine: | Oil pressure, coolant temperature, overcrank, ECU-specific elements, and diagnostic reporting. |

Agency Approvals

- CSA certified, NFPA compliant, CE compliant,
- UL recognized (Hazardous Location certification available upon request), EAC certified

Communication

| | |
|---------------------|--|
| USB Port: | USB 2.0, Mini-B jack |
| RS-485 (optional): | 9600 baud, 8 data bits, no parity |
| RDP-110 (optional): | 4,000 ft (1,219 m) max wire length, 20 AWG (0.52 mm ²) min wire size |
| Modem (optional): | DB-9 connector (male) |
| CAN bus: | 250 kb/s communication rate, 1.5 to 3 Vdc differential bus |

Environmental

| | |
|---------------------|---------------------------------------|
| Operating Temp: | -40°C to 70°C (-40°F to 158°F) |
| Storage Temp: | -40°C to 85°C (-40°F to 185°F) |
| Humidity: | IEC 68-2-38 |
| Salt Fog: | ASTM B 17-73, IEC 68-2-11 |
| Ingress Protection: | IEC IP54 for front panel |
| Shock: | 15 G in three perpendicular planes |
| Vibration: | |
| 5 to 29 Hz: | 1.5 G peak |
| 29 to 52 Hz: | 0.036" (0.914 mm) double amplitude |
| 52 to 500 Hz: | 5 G peak |

Physical

| | |
|---------------------|---|
| Weight: | 4.4 lb (2 kg) |
| Dimensions (WxHxD): | 11.77 x 8.27 x 2.69 inches (299 x 210 x 69 mm) |

For complete specifications, download the instruction manual at www.basler.com.

STYLE CHART

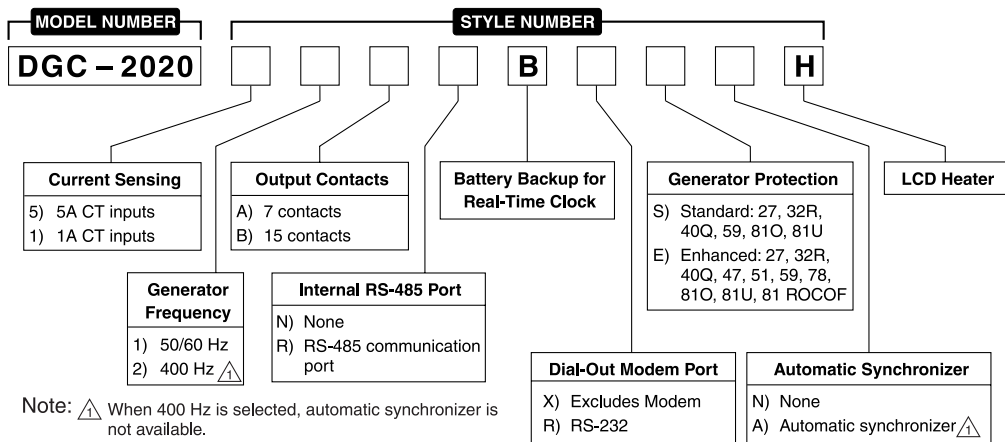

RELATED PRODUCTS

- [BE1-11g Generator Protection System](#)
- A complete generator protection system.
- [DECS-250 Digital Excitation Control System](#)
- Total control in a compact package provides precise voltage, var and power factor regulation, exceptional system response, and generator protection.

ACCESSORIES

- [AEM-2020 Analog Expansion Module](#)
- Easily increases the functionality by seamlessly adding analog inputs and outputs.
- [CEM-2020, CEM-2020H Contact Expansion Module](#)
- Each module adds 10 inputs and up to 24 outputs that are easily programmed through BESTCOMSPUs[®] for easy integration into the system.
- [LSM-2020 Load Share Module](#)
- The simple-to-use LSM-2020 easily adds paralleling capabilities with little effort and expense.
- [RDP-110 Remote Display Panel](#)
- Provides remote alarm and pre-alarm indication and annunciation of system status, easily meeting the annunciation requirements of NFPA-110 applications.



12570 State Route 143, Highland, Illinois 62249-1074 USA
Tel +1 618.654.2341 Fax +1 618.654.2351
email: info@basler.com www.basler.com

P.A.E. Les Pins, 67319 Wasselonne Cedex, FRANCE
Tel +33 3.88.87.1010 Fax +33 3.88.87.0808
e-mail: franceinfo@basler.com

No. 59 Heshun Road Loufeng District (N),
Suzhou Industrial Park, 215122, Suzhou, P.R.China
Tel +86(0)512.8227.2888 Fax +86(0)512.8227.2887
e-mail: chinainfo@basler.com

111 North Bridge Road #15-06 Peninsula Plaza
Singapore 179098
Tel +65 68.44.6445 Fax +65 68.44.8902
e-mail: singaporeinfo@basler.com

Annex to the
technical catalog



Tmax T8

Low voltage molded case
circuit breaker up to 3000 A

UL 489 and CSA C22.2 Standard

1SDC210026D0201 – 2008 Edition



ABB

Main characteristics

The Tmax family, conforming to the UL 489 and CSA C22.2 No. 5.1 Standards, is enriched with the Tmax T8 size, which allows 3000 A to be reached. Also available in the 1600 A, 2000 A and 2500 A frames, Tmax T8 is equipped with the same electronic trip units as Tmax T7, thereby guaranteeing extremely high performances able to satisfy all installation requirements. Adequately sized for the performances offered (W=16.8 / D=11.2 / H=15.0 in). Tmax T8 is able to interrupt the following short-circuit currents: 125 kA@480 V and 100 kA@600 V.



Main characteristics

General characteristics

The Tmax T8 size has both circuit breakers and molded case switches (MCS). The following tables show the main characteristics of these ranges.

Circuit breakers for power distribution

| | | | Tmax T8 |
|-------------------------------|------------------|--------------|---------------------|
| Frame size | | [A] | 1600/2000/2500/3000 |
| Number of poles | | [No] | 3/4 |
| Rated voltage | (AC) 50-60 Hz | [V] | 600 |
| | (DC) | [V] | – |
| Test voltage (1 min) 50-60 Hz | | [V] | 3000 |
| Interrupting ratings | | [kA rms] | V |
| | 240 V AC | [kA rms] | 125 |
| | 480 V AC | [kA rms] | 125 |
| | 600 V AC | [kA rms] | 100 |
| Trip units | Electronic | PR232/P-T8 | ■ |
| | | PR331/P | ■ |
| | | PR332/P | ■ |
| Dimensions fixed version (3p) | H | [in-mm] | 15.0 - 382 |
| | W | [in-mm] | 16.8 - 427 |
| | D | [in-mm] | 11.2 - 282 |
| Mechanical life | | [operations] | 15000 |
| Weight (fixed 3p) | 1600/2000/2500 A | [lbs] | 161 |
| | 3000 A | [lbs] | 236 |

Molded case switches (MCS)

The Tmax T8 MCS are derived from the corresponding circuit breakers, of which they keep the overall dimensions, the versions, the fixing systems and the possibility of mounting accessories unchanged. This version only differs from the circuit breakers in the absence of the protection trip units. All molded case switches comply with the UL 489 and CSA C22.2 Standards and are self-protected.

| | | | Tmax T8V-D |
|-------------------|---------------|------|-------------------|
| Rating | | [A] | 2000/2500/3000 |
| Poles | | [No] | 3/4 |
| Magnetic override | | [A] | 40000 |
| Rated voltage | AC (50-60 Hz) | [V] | 600 |
| | DC | [V] | – |

Tmax-Molded Case Circuit Breakers

T7 1200A Frame

AC Circuit Breakers and Switches

3 and 4 Pole

Motor Circuit Protectors

Higher Performances in Less Space

Field Installable Accessories and Trip Units



Dimensions 3P Fixed Version 10.55H x 8.26W x 6.06D

Weight 21.4 (lbs)

Compliance with Standards

UL 489

CSA C22.2 No.5.1

IEC 60947-2

Standards

EC directive:

– “Low Voltage Directives” (LVD) no. 73/23 EEC

– “Electromagnetic Compatibility Directive” (EMC) no.89/336 EEC

The ABB Quality System complies with the international ISO 9001 - 2000 Standard (model for quality assurance in design, development, construction, and installation and service) and with the equivalent European EN ISO 9001 and Italian UNI EN ISO 9001 Standards

| Interrupting ratings (RMS sym. kAmps) | | T7 | | |
|---------------------------------------|------|------|-----|-----|
| Continuous Current Rating | | 1200 | | |
| Number of Poles | | 3-4 | | |
| | | S | H | L |
| AC | | | | |
| | 240V | 65 | 100 | 150 |
| | 480V | 50 | 65 | 100 |
| | 600V | 25 | 50 | 65 |



Company Quality Systems and Environmental Systems

The new Tmax series has a hologram on the front, obtained using special anti-imitation techniques, which guarantees the quality and that the circuit breaker is an original ABB product.

Attention to protection of the environment and to health and safety in the work place is another priority commitment for ABB and, as confirmation of this, the company environmental management system has been certified by RINA in 1997, in conformity with the international ISO 14001 Standard. This certification has been integrated in 1999 with the Management System for Health and Safety in the workplace, according to OHSAS 18001 (British Standards), obtaining one of the first certification of integrated management System, QES (Quality, Environment,

Safety) issued by RINA. ABB - the first industry in the electro-mechanical section in Italy to obtain this recognition - thanks to a revision of the production process with an eye to ecology has been able to reduce the consumption of raw materials and waste from processing by 20%. ABB's commitment to safeguarding the environment is also shown in a concrete way by the Life Cycle Assessments of its products carried out directly by the ABB Research and Development in collaboration with the ABB Research Center. Selection of materials, processes and packing materials is made optimizing the true environmental impact of the product, also foreseeing the possibility of its being recycled.

Mounting

Fixed
Drawout

Connections

Busbar connection or compression lugs
Pressure-type terminals for bare cables
Rear connections

Trip Unit

PR231/P, PR232/P, PR331DS, and PR332DS/P electronic trip unit

Auxiliary Devices for Indication and Control

- Auxiliary contacts - AUX
- Undervoltage release - UVR
- Shunt trip - SOR
- Terminal covers
- Padlock provision - PLL
- Direct rotary handle - RHD
- Key lock - KLF
- Early auxiliary contact - AUE
- Transmitted rotary handle - RHE
- Front extended terminal - EF
- Front terminal for copper-aluminum - FC CuAl
- Front extended spread terminal - ES
- Rear orientated terminal - R
- Phase separators
- Residual current relay (IEC Only)



ABB Inc.

1206 Hatton Road
Wichita Falls, TX 76302
For more information and
the location of your local
field office please go to
www.abb-control.com

Tmax-Molded Case Circuit Breakers

T5 400A and 600A Frame

AC Circuit Breakers and Switches

DC Circuit Breakers and Switches (400A Only)

3 and 4 Pole

Motor Circuit Protectors

Higher Performances in Less Space

Field Installable Accessories and Trip Units



Dimensions 3P Fixed Version 8.07H x 5.51W x 4.07D

Compliance with Standards

UL 489

CSA C22.2 No.5.1

IEC 60947-2

Standards

EC directive:

- "Low Voltage Directives" (LVD) no. 73/23 EEC

- "Electromagnetic Compatibility Directive" (EMC) no.89/336 EEC

The ABB Quality System complies with the international ISO 9001 - 2000 Standard (model for quality assurance in design, development, construction, and installation and service) and with the equivalent European EN ISO 9001 and Italian UNI EN ISO 9001 Standards

Interrupting ratings (RMS sym. kAmps)

T5

Continuous Current Rating

400-600A

Number of Poles

3-4

| | | N | S | H | L | V |
|--------------------|-------------------|----|-----|-----|-----|-----|
| AC | | | | | | |
| 240V | | 65 | 100 | 150 | 200 | 200 |
| 480V | | 25 | 35 | 65 | 100 | 150 |
| 600V | | 18 | 25 | 35 | 65 | 100 |
| DC* (400 A only) | | | | | | |
| 500V | 2 poles in series | 25 | 35 | 50 | 65 | 100 |
| 600V | 3 poles in series | 16 | 25 | 35 | 50 | 65 |

*Thermo Magnetic Trip Only



Company Quality Systems and Environmental Systems

The new Tmax series has a hologram on the front, obtained using special anti-imitation techniques, which guarantees the quality and that the circuit breaker is an original ABB product.

Attention to protection of the environment and to health and safety in the work place is another priority commitment for ABB and, as confirmation of this, the company environmental management system has been certified by RINA in 1997, in conformity with the international ISO 14001 Standard. This certification has been integrated in 1999 with the Management System for Health and Safety in the workplace, according to OHSAS 18001 (British Standards), obtaining one of the first certification of integrated management System, QES (Quality, Environment,

Safety) issued by RINA. ABB - the first industry in the electro-mechanical section in Italy to obtain this recognition - thanks to a revision of the production process with an eye to ecology has been able to reduce the consumption of raw materials and waste from processing by 20%. ABB's commitment to safeguarding the environment is also shown in a concrete way by the Life Cycle Assessments of its products carried out directly by the ABB Research and Development in collaboration with the ABB Research Center. Selection of materials, processes and packing materials is made optimizing the true environmental impact of the product, also foreseeing the possibility of its being recycled.

Mounting

Fixed
Plug-in
Drawout

Connections

Busbar connection or compression lugs
Pressure-type terminals for bare cables
Rear connections

Trip Unit

TMA thermo magnetic trip units, with adjustable thermal threshold ($I_1 = 0.7 \dots 1 \times I_n$) and adjustable magnetic threshold ($I_3 = 5 \dots 10 \times I_n$).

PR221DS, PR222DS/P and PR222DS/PD-A electronic trip unit

| | |
|---------------------|------|
| Weight (lbs) | 8.55 |
|---------------------|------|

Auxiliary Devices for Indication and Control

- Auxiliary contacts - AUX
- Undervoltage release - UVR
- Shunt trip - SOR
- Terminal covers
- Front for lever operating mechanism - FLD
- Direct rotary handle - RHD
- Stored energy motor operator - MOE
- Key lock - KLF
- Early auxiliary contact - AUE
- Transmitted rotary handle - RHE
- Front terminal for copper cable - FC Cu
- Front extended terminal - EF
- Front terminal for copper-aluminum - FC CuAl
- Front extended spread terminal - ES
- Distribution lugs
- Rear orientated terminal - R
- Phase separators
- Residual current release (IEC Only)



ABB Inc.

1206 Hatton Road
Wichita Falls, TX 76302
For more information and
the location of your local
field office please go to
www.abb-control.com

Digital Linear Chargers

On-Board Chargers Today

- Current Supplier provides quality product and design services. However, services are at their pacing with limited resources; and a history of issues meeting launch dates. PC charger delays prompted a re-evaluation of our controls and processes
- Resulted in a renewed commitment to the charger category
 - Allow supplier to focus on what they do well... build product
 - All charger development controlled by Minn Kota engineering
- Minn Kota designs, tests, and qualifies
- Supplier manufactures – period
- Revised product plan
 - 2011 Digital Linear On-board chargers
 - 2012 Precision Charge On-board chargers

New Digital Linear On-Board Chargers

- Taking existing Linear On-board family of chargers and raising the bar
 - Analog to Digital designs; New “D” designation in model name



Digital Linear Chargers

New Digital Linear On-Board Chargers (cont.)

- New microprocessor controlled linear design provides software enriched features and functionality
 - More repeatable set points (voltage limit and current) = improved charge curves
 - Maintenance mode time-out feature (auto-off)
 - Arc protection
 - Enhanced status codes
 - System okay
 - Charge stage indication (Bulk, Absorption, or Maintenance)
 - Full charge
 - Maintenance mode status
 - Multiple specific error indications – low battery voltage, damaged temp sensor, no output lead attached, etc.
- Up to 2X Faster Charge Times in high heat conditions

LED Status Code Detail

1. A GREEN power light is lit to indicate AC power is applied
2. A YELLOW light is lit for each bank to indicate the battery is charging in the Bulk Mode
3. A flashing YELLOW light is lit for each bank to indicate the battery is charging in the Absorption Mode
4. A flashing GREEN light is lit for each bank to indicate the battery is in maintenance mode and ready to use
5. A GREEN light is lit for each bank to indicate the battery is in long term maintenance mode and ready to use
6. A RED light for each bank is lit if any of the following apply:
 - a) No battery is connected to an output cord - this may also indicate a blown fuse in the fuse holder
 - b) The battery is connected reverse polarity
 - c) A short circuit
 - d) The battery voltage is below 4 volts - the bank will not charge a battery in this condition

Digital Linear Chargers

LED Status Code Detail (cont.)

- e) The battery voltage is above 18 volts - the bank will not charge a battery in this condition
7. A flashing RED light is lit for each bank if there is a damaged temperature sensor on the output cord - the bank will not operate if this occurs.
8. Flashing RED and GREEN lights are lit for each bank if any of the following apply:
 - a) The battery voltage does not rise above 10.5V after 3 hours - the battery may be damaged and will not be charged
 - b) Charging in Bulk Mode exceeds 20 hours - the battery may be damaged and will not be charged

Digital Linear Charging Technologies

Automatic 3-Stage Charging

- Bulk – high amps at low voltage until battery reaches ~75% charge
- Absorption – at ~75% charge, current tapers down until the battery voltage reaches 14.4V* (full charge)
- Maintenance (or Float) – when the battery voltage reaches full charge, charger output is dropped to 13.4V* (.1A-.3A). After 24 hours, the charger automatically turns off and automatically turns on when the battery voltage drops below 12.6 volts

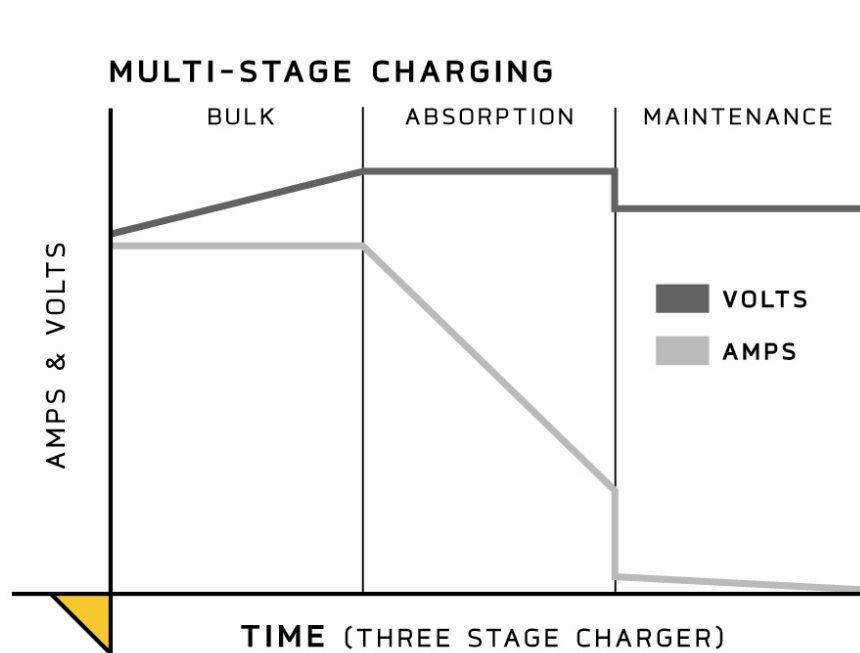

* At 77 degrees Fahrenheit

Digital Linear Chargers

Digital Linear Charging Technologies (cont.)

Automatic Temperature Compensation

- Senses temperature and adjusts output voltage
- Protects batteries from overcharging at high temperatures
- Maintains gassing threshold for a full charge

Gassing Threshold

- Voltage level at which electrolyte begins moving within the battery
- This threshold must be reached in order to fully charge a battery

Effect of Temperature

- Gassing threshold is higher at lower temps, lower at higher temps
- Too much voltage at high temperatures can “boil” and destroy a battery

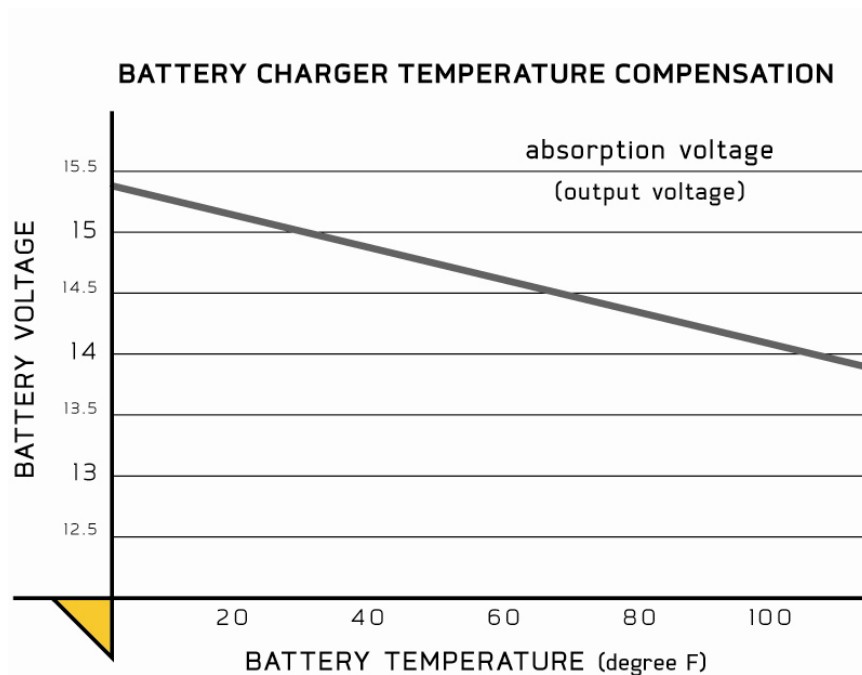

Digital Linear Chargers

Specifications

- Waterproof, shock-and vibration-resistant aluminum construction
- Saltwater tested and fully corrosion-resistant
- Short circuit, reverse polarity, and ignition protected
- For use with 12V/6 cell batteries that are flooded/wet cell, maintenance free or starved electrolyte (AGM) only
- FCC compliant
- UL listed to marine standard 1236
- 3 year warranty
- Replaces all existing current on-board chargers (excluding portables)
- No Price Increase
- Availability: November 2010



DIGITAL LINEAR ON-BOARD CHARGERS

| PRODUCT CODE | PRODUCT DESCRIPTION |
|--------------|----------------------------|
| 1821065 | MK 106D (1 bank x 6 amps) |
| 1821105 | MK-110D (1 bank x 10 amps) |
| 1822105 | MK-210D (2 bank x 5 amps) |
| 1823155 | MK-315D (3 bank x 5 amps) |
| 1822205 | MK-220D (2 bank x 10 amps) |
| 1823305 | MK-330D (3 bank x 10 amps) |
| 1824405 | MK-440D (4 bank x 10 amps) |
| 1822305 | MK-230D (2 bank x 15 amps) |
| 1823455 | MK-345D (3 bank x 15 amps) |
| 1824605 | MK-460D (4 bank x 15 amps) |

T4D-4000 OPEN DIMENSIONAL OVERVIEW

TOP VIEW

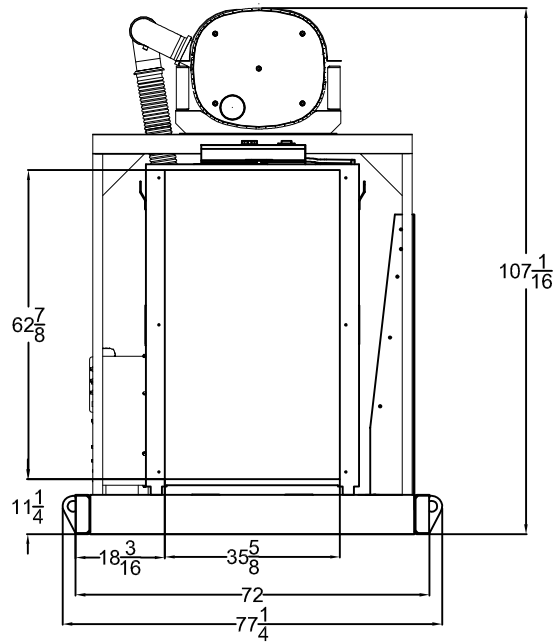
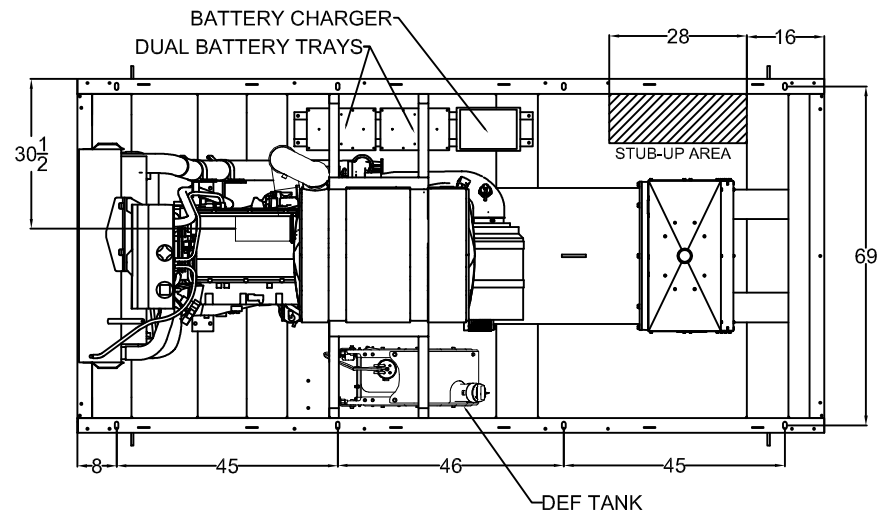

RADIATOR VIEW

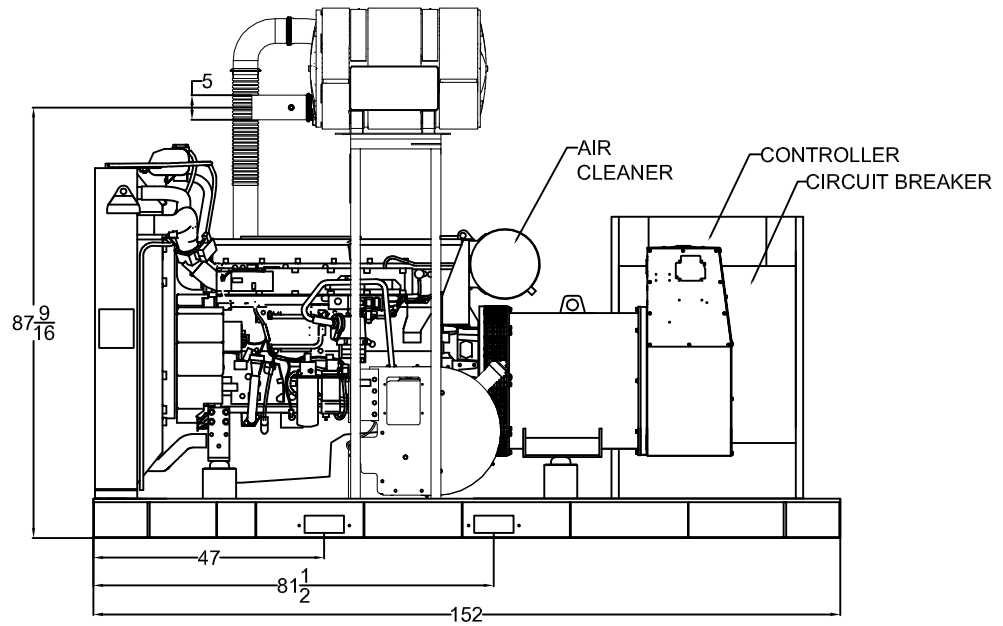

SIDE VIEW

T4D-3500 THRU T4D-4000 LEVEL 2 ENCLOSURE OUTLINE DIMENSIONS WITH RESIDENTIAL GRADE SILENCER

TOP VIEW

(GEN-SET HAS (6) DOORS, (3) SHOWN OPEN ARE TYPICAL FOR BOTH SIDES)

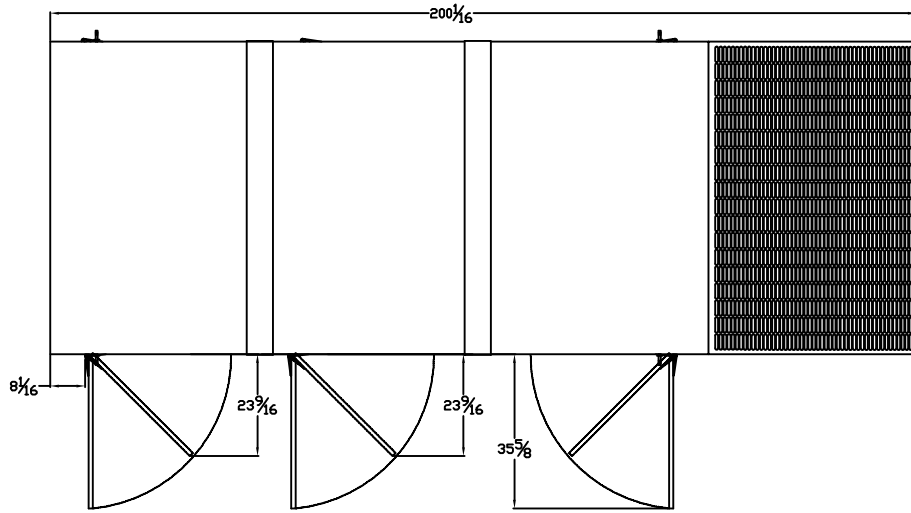

FRAME VIEW

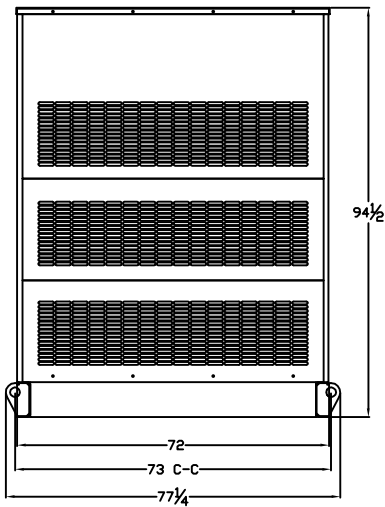
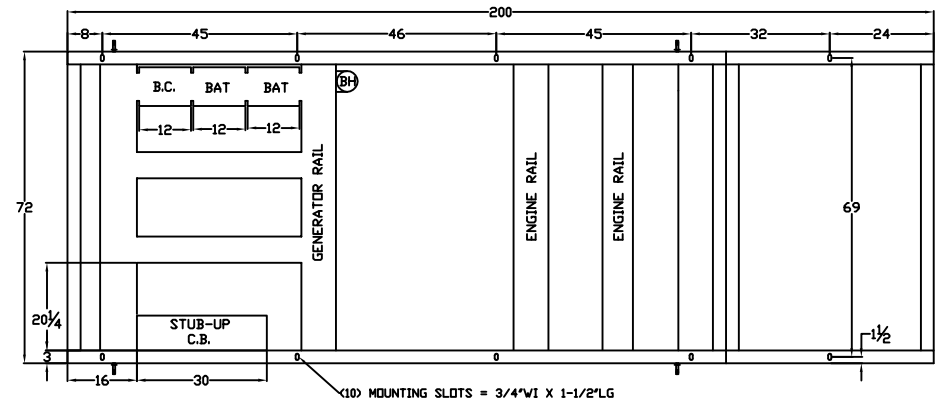

GENERATOR END VIEW

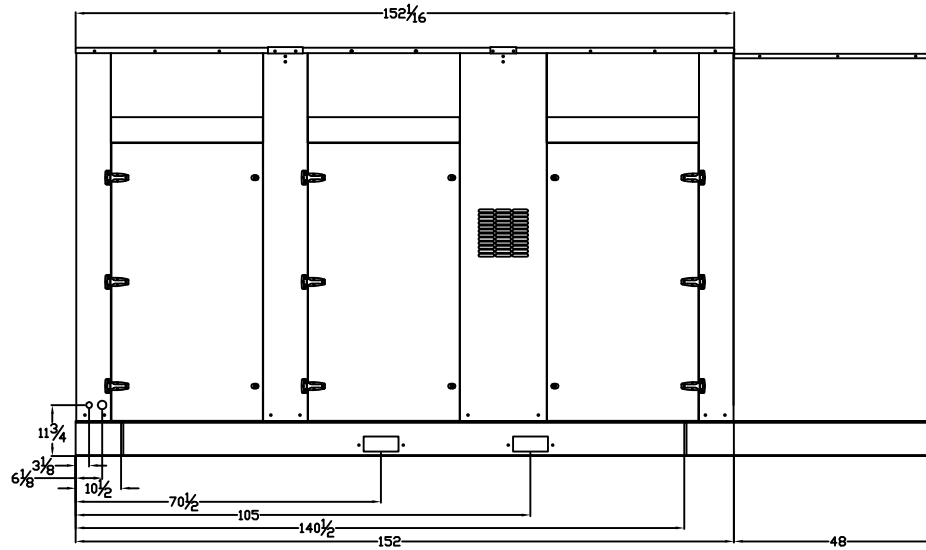

SIDE VIEW

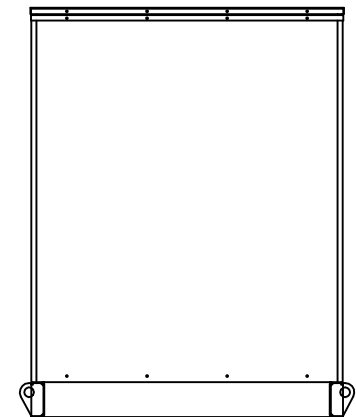

RADIATOR END VIEW