



# GILLETTE GENERATORS

60 HZ MODEL  
**SPVD-4000**

**LIQUID COOLED DIESEL ENGINE GENERATOR SET**

Model	HZ	STANDBY 120°C RISE
	60	400
<b>SPVD-4000-60 HERTZ</b>		



All generator sets are USA prototype built and thoroughly tested. Production models are USA factory built and 100% load tested.



**UL2200, UL1446, UL508, UL142, UL498**



**NFPA 110, 99, 70, 37**

All generator sets meet NFPA-110 Level 1, when equipped with the necessary accessories and installed per NFPA standards.



**NEC 700, 701, 702, 708**



**NEMA ICS10, MG1, ICS6, AB1**



**ANSI C62.41, 27, 59, 32, 480, 40Q, 81U, 360-05**



**ASCE 7-05 & 7-10**

All generator sets meet 180 MPH rating.



**EPA 40CFR Part 60, 1048, 1054, 1065, 1068**

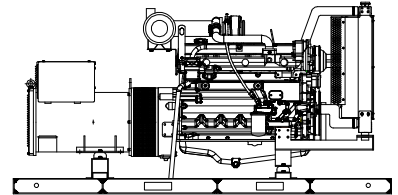

“OPEN” GEN-SET

There is no enclosure, so gen-set must be placed within a weather protected area, uninhabited by humans or animals, with proper ventilation. Silencer not supplied, as installation requirements are not known. However, this item is available as optional equipment.

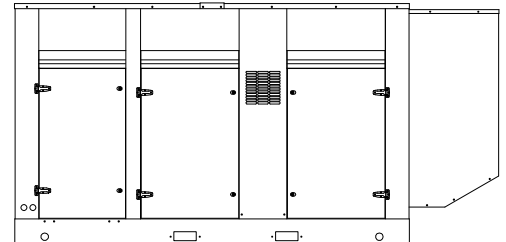

“LEVEL 2” HOUSED GEN-SET

Full aluminum weather protection and superior sound attenuation for specific low noise applications. Critical grade muffler is standard.

## GENERATOR RATINGS

GENERATOR MODEL	VOLTAGE		PH	HZ	120°C RISE STANDBY RATING		POWER LEAD CONNECTIONS
	L-N	L-L			KW/KVA	AMP	
SPVD-4000-3-2	120	208	3	60	400/500	1390	12 LEAD LOW WYE
SPVD-4000-3-3	120	240	3	60	400/500	1200	12 LEAD HIGH DELTA
SPVD-4000-3-4	277	480	3	60	400/500	600	12 LEAD HIGH WYE
SPVD-4000-3-5	127	220	3	60	400/500	1314	12 LEAD LOW WYE
SPVD-4000-3-16	346	600	3	60	400/500	481	4 LEAD DEDICATED 3 PH

RATINGS: All single phase gen-sets are dedicated 4 lead windings, rated at unity (1.0) power factor. All three phase gen-sets are 12 lead windings, rated at .8 power factor. 120° C “STANDBY RATINGS” are strictly for gen-sets that are used for back-up emergency power to a failed normal utility power source. This standby rating allows varying loads, with no overload capability, for the entire duration of utility power outage. All gen-set power ratings are based on temperature rise measured by resistance method as defined by MIL-STD 705C and IEEE STD 115, METHOD 6.4.4. All generators have class H (180°C) insulation system on both rotor and stator windings. All factory tests and KW/KVA charts shown above are based 120°C (standby) R/R winding temperature, within a maximum 40°C ambient condition. Generators operated at standby power ratings must not exceed the temperature rise limitation for class H insulation system, as specified in NEMA MG1-22.40. Specifications & ratings are subject to change without prior notice.

# APPLICATION & ENGINEERING DATA FOR MODEL SPVD-4000-60 HZ

## GENERATOR SPECIFICATIONS

Manufacturer.....Stamford Electric Generators  
Model & Type..... S4L1D-G311, 4 Pole, 12 Lead, Three Phase  
.....S4L1D-F311, 4 Pole, 12 Lead, 480V, Three Phase  
.....HCI434F-17, 4 Pole, 6 Lead, 600V, Three Phase  
Exciter.....Brushless, shunt excited  
Voltage Regulator.....Solid State, HZ/Volts  
Voltage Regulation.....½%, No load to full load  
Frequency.....60 HZ  
Frequency Regulation.....± ½% (1/2 cycle, no load to full load)  
Unbalanced Load Capability.....100% of standby amps  
One Step Load Acceptance.....100% of nameplate rating  
Total Stator and Load Insulation.....Class H, 180°C  
Temperature Rise.....120°C R/R, standby rating @ 40°C amb.  
3 Ø Motor Starting @ 30% Voltage Dip (208-240V).....490 kVA  
3 Ø Motor Starting @ 30% Voltage Dip (480V).....1100 kVA  
3 Ø Motor Starting @ 30% Voltage Dip (600V).....1260 kVA  
Bearing.....1, Pre-lubed and sealed  
Coupling.....Direct flexible disc.  
Total Harmonic Distortion.....Max 3½% (MIL-STD705B)  
Telephone Interference Factor.....Max 50 (NEMA MG1-22)  
Deviation Factor.....Max 5% (MIL-STD 405B)  
Alternator.....Self ventilating and drip-proof  
Ltd. Warranty Period.....24 Months from start-up date or  
.....1000 hours use, first to occur.

## GENERATOR FEATURES

- World Renown Stamford Electric Generator having UL-1446 certification.
- Full generator protection with **Basler DGC-2020** controller, having UL-508 certification.
- Automatic voltage regulator with over-excitation, under-frequency compensation, under-speed protection, and EMI filtering. Entire solid-state board is encapsulated for moisture protection.
- Generator power ratings are based on temperature rise, measured by resistance method, as defined in MIL-STD 705C and IEEE STD 115, Method 6.4.4.
- Power ratings will not exceed temperature rise limitation for class H insulation as per NEMA MG1-22.40.
- Insulation resistance to ground, exceeds 1.5 meg-ohm.
- Stator receives 2000 V. hi-potential test on main windings, and rotor windings receive a 1500 V. hi-potential test, as per MIL-STD 705B.
- Full amortisseur windings with UL-1446 certification.
- Complete engine-generator torsional acceptance, confirmed during initial prototype testing.
- Full load testing on all engine-generator sets, before shipping.

## ENGINE SPECIFICATIONS AND APPLICATIONS DATA

### ENGINE

Manufacturer.....VOLVO-PENTA  
Model and Type.....TAD1353GE, 4 cycle, liquid Cooled  
Aspiration.....Turbo After Cooler, Air to Air  
Charged Air Cooled System.....Air to Air  
Cylinder Arrangement.....6 Cylinders, In-Line  
Displacement Cu. In. (Liters).....780(12.8)  
Bore & Stroke in (Cm).....5.16 x 6.22 (13.1 x 15.8)  
Compression Ratio.....18:1  
Main Bearings.....Tin Overlay with Babbit Backing  
Cylinder Head.....Cast Iron with overhead Cam  
Pistons.....Aluminum Alloy with Graphite Coating  
Crankshaft.....Induction Hardened, Heat Treated Forged  
Valves.....Heat Treated and Hardened Exhaust Valve  
Governor.....Electronic, EMS 2.2  
Frequency Regulation.....± 1/4%  
Air Cleaner.....Dry, Replaceable Cartridge  
Engine Speed.....1800 rpm  
Max Power, bhp (kwm) Standby.....611 (449)  
BMEP: psi (MPa) Standby.....340 (2.3)  
Ltd. Warranty Period.....2 Year or 1000 hrs, first to occur

### FUEL SYSTEM

Type.....Diesel Fuel Oil (ASTM No. 2-D)  
Combustion System.....Direct Injection  
Fuel Injection Pump.....Electronic, Delphi E3  
24 VDC Coolant heaters.....Optional Equipment  
Fuel Filter.....Yes with Water Separator

### FUEL CONSUMPTION

GAL/HR (LITER/HR)	STANDBY
100% LOAD	27.9 (105.6)
75% LOAD	21.9 (82.9)
50% LOAD	15.0 (56.8)

### OIL SYSTEM

Type.....Full Pressure  
Oil Pan Capacity qt. (L).....31.6 (29.9)  
Oil Pan Cap. W/ filter qt. (L).....38 (35.9)  
Oil Filter.....3, Replaceable Cartridge type

### ELECTRICAL SYSTEM

Ignition System.....Electronic  
Eng. Alternator/Starter: 24 VDC, negative ground, 80 amp/hr.

Recommended battery to -18°C (0° F): ... (2) 12 VDC, BCI# 27, Max. Dimensions: 12"lg x 6 3/4" wi x 9" hi, with standard round posts. Min output 700 CCA. Battery tray (max. dim. at 12"lg x 7"wi). This model has (2) battery trays, (2) hold down straps, (2) sets of battery cables, and (1) battery charger. Installation of (2) 12VDC starting batteries connected in series for 24VDC output is required, with possible higher AMP/HR rating, as described above, if the normal environment temperature averages -13° F (-25°C) or cooler.

### CERTIFICATIONS

All engines are EPA emissions certified. All emergency stationary diesel engines are Tier III compliant.

# APPLICATION & ENGINEERING DATA FOR MODEL SPVD-4000-60 HZ

## COOLING SYSTEM

Type of System ..... Air to Air, Charged Air Cooler  
 Coolant Pump .....Pre-lubricated, self-sealing  
 Cooling Fan Type .....Pusher  
 Fan Diameter inches (cm).....35.1 (89)  
 Fan drive ratio..... 0.99:1  
 Ambient Capacity of Radiator °F (°C)..... 131 (55)  
 Engine Jacket Coolant Capacity gal. (L).....5.28 (20)  
 Radiator Coolant Capacity gal. (L)..... 11.7 (44)  
 Water Pump Capacity gpm (L/min)..... 87.0 (329)  
 Heat Reject Coolant: Btu/min .....10,123  
 Air to Air Heat Reject, BTU/min. ....5,346  
 Heat Radiated to Ambient, BTU/min .....3,415  
 Low Radiator Coolant Level Shutdown.....Standard  
 Note: Coolant temp. shut-down switch setting at 228°F (109°C) with 50/50 (water/antifreeze) mix.

## COOLING AIR REQUIREMENTS

Combustion Air cfm (m<sup>3</sup>/min) ..... 1,102 (31.2)  
 Max Air Intake Restrictions:  
 Clean Air Cleaner, KPA (psi) ..... 5 (1.5)  
 Radiator Cooling Air, SCFM (m<sup>3</sup>/min).....24,175 (684)

## EXHAUST SYSTEM

Exhaust Outlet Size .....6"  
 Max. Back Pressure in KPA (in. H<sub>2</sub>O)..... 10 (40)  
 Exhaust Flow, at rated KW, CFM (m<sup>3</sup>/min)..... 2,790 (79)  
 Exhaust Temp, (Stack) °F (°C) .....923 (495)

## SOUND LEVELS MEASURED IN dB(A)

	Open Set	Level 2 Encl.
Level 2, Critical Silencer .....	90	80
Level 3, Hospital Silencer.....		75

Note: Open sets (no enclosure) have optional silencer system choices due to unknown job-site applications. Level 2 enclosure has installed critical silencer with upgrade to Level 3 hospital silencer. Sound tests are averaged from several test points and taken at 23 ft. (7 m) from source of noise at normal operation.

## DERATE GENERATOR FOR ALTITUDE

3% per 1000 ft.(305 meters) above 3000 ft. (914 meters) from sea level.

## DERATE GENERATOR FOR TEMPERATURE

2% per 10°F (12°C) above 104°F (40°C)

## DIMENSIONS AND WEIGHTS

	Open Set	Level 2 Enclosure
Length in (cm).....	132 (335)	174 (442)
Width in (cm).....	52 (132)	52 (132)
Height in (cm).....	65 (165)	80 (203)
Net Weight lbs (kg).....	7292 (3308)	8699 (3946)
Ship Weight lbs (kg).....	7593 (3444)	9064 (4111)

# BASLER DGC-2020 DIGITAL MICROPROCESSOR CONTROLLER

### Basler DGC-2020



The “2020” controller is a highly advanced integrated gen-set control system for single gen-set applications. This controller includes a backlit LCD display which continuously displays the status of the engine and generator at all times.

Basler “DGC-2020” includes: Generator metering (including three phase) • Engine – Generator protections including IEEE-[27] under voltage, [32] power, [40] loss of excitation, [59] over voltage, [81] over and under frequency, Exercise timer • SAE J1939 engine ECU communications • Expansion capabilities for both inputs and outputs with expansion • Remote communications through RS-485 to Basler’s RDP110 remote Display panel • (16) programmable contact inputs • (15) programmable contact outputs- (3) for up to 30AmpDC and (12) for up to 2 Amp DC • Illuminated Text Display • Front panel menu scroll buttons • Front panel operation mode buttons for STOP, RUN and AUTO • Alarm Silence and Lamp Test buttons

This controller includes expansion features including, RS485 (using MODBUS), direct USB connection with PC, expansion optioned using BESTCOMSPPlus for remote annunciation and remote relay interfacing for a distance of up to 3300FT. The controller software is freely downloadable from the internet and allows monitoring with direct USB cable, LAN, or by internet via the built in web interface.



Further expansion is available by adding the optional RDP-110 remote display panel module. This featured device will allow Four programmable LEDs (2) alarms and (2) pre-alarms • (17) alarms and pre-alarms displayed from Basler controller • audible alarm horn • lamp test and alarm silence buttons • RD100 local power supply inputs of either 12vdc or 24vdc • connects through Basler controller through RS-485 communications protocol • conduit box included for (2) mounting configurations- either surface mount or semi-flush mounting.

# STANDARD FEATURES FOR MODEL SPVD-4000-60 HZ

## STANDARD FEATURES

### CONTROL PANEL:

- Basler DGC-2020 digital microprocessor with logic allows programming in the field. Controller has:
- STOP-MANUAL-AUTO modes and automatic engine shutdowns, signaled by full text LCD indicators:
  - Low oil pressure
  - High engine temp
  - Low Radiator Level
  - Three auxiliary alarms
  - Battery fail alarm
  - Engine fail to start
  - Engine over speed
  - Engine under speed
  - Over & under voltage

Also included is tamper-proof engine hour meter

### ENGINE:

- Fuel filter
- Full flow Oil filter
- Air filter
- Fuel pump
- Oil pump
- Solenoid type starter motor
- Hi-temp radiator
- Jacket water pump
- Thermostat
- Pusher fan and guard
- Exhaust manifold
- Electronic Governor
- 24 VDC battery charging alternator
- Flexible fuel and exhaust connectors
- Vibration isolators
- Open coolant recovery system with 50/50 water to anti-freeze mixture
- flexible oil & radiator hose
- Shut-down sensors for low oil pressure, high coolant temp., low coolant level, high ambient temp.

### AC GENERATOR SYSTEM:

- AC generator
- Shunt excited
- Brushless design
- Circuit Breaker installed and wired to gen-set
- Direct connection to engine with flex disc
- Class H, 180°C insulation
- Self ventilated
- Drip proof construction
- UL Certified

### VOLTAGE REGULATOR:

- 1% Voltage regulation
- EMI filter
- Under-speed protection
- Over-excitation protection
- total encapsulation

### DC ELECTRICAL SYSTEM:

- Battery trays
- Battery cables
- Battery hold down straps
- 3-stage battery charger with float, absorption, & bulk automatic charge stages

### WEATHER / SOUNDPROOF ALUMINUM HOUSING:

Corrosion Resistant Protection consisting of:

- (9) Heated and Agitated Wash Stages
- Zinc Phosphate Etching-Coating Stage
- Final Baked on Enamel Powder Coat
- 18/8 Stainless Steel Hardware

Design & specifications subject to change without prior notice. Dimensions shown are approximate. Contact Gillette for certified drawings.

DO NOT USE DIMENSIONS FOR INSTALLATION PURPOSES.

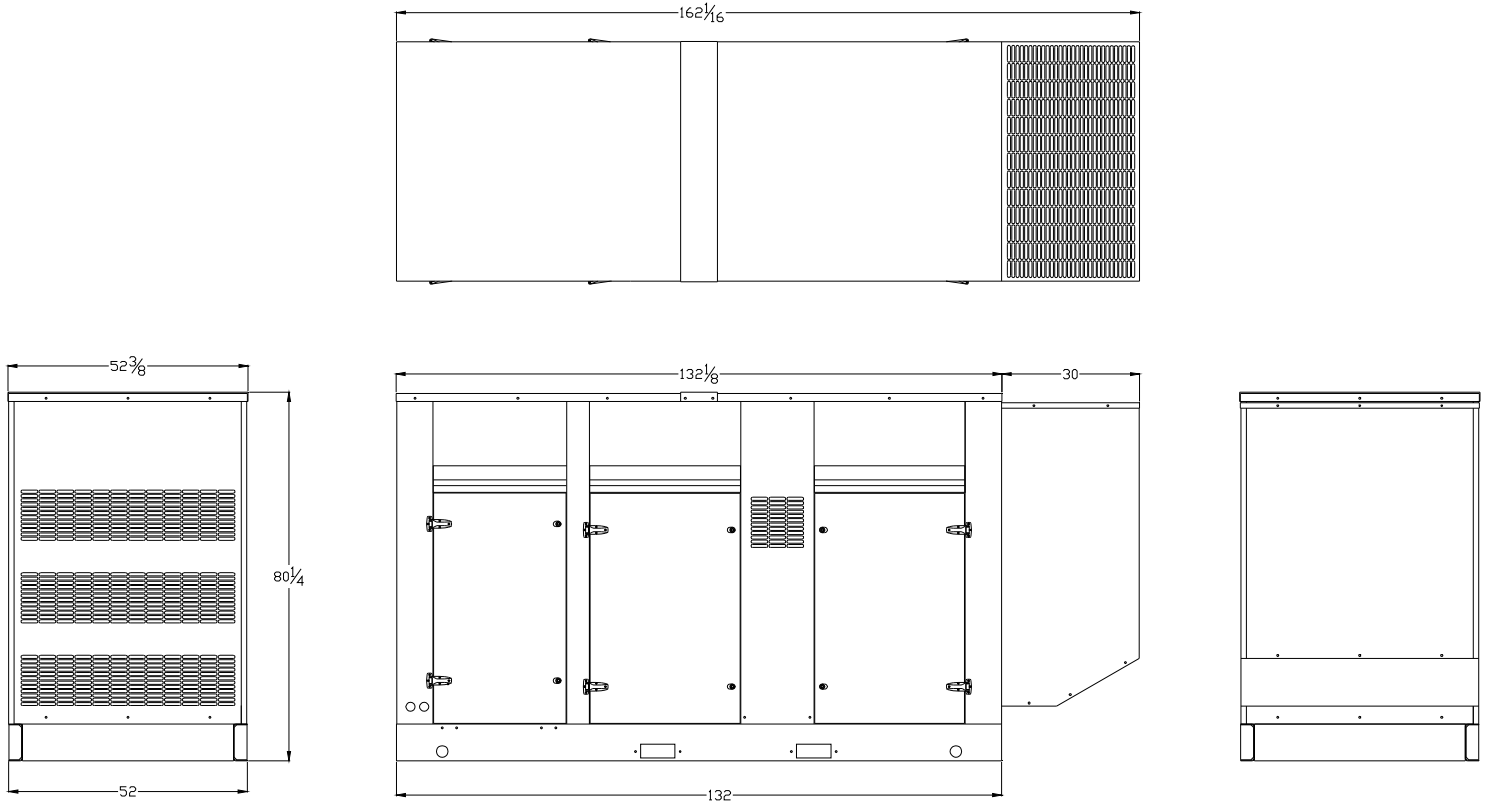



# VOLVO PENTA GENSET ENGINE

# TAD1353GE

449 kW (611 hp) at 1800 rpm, acc. ISO 3046

The TAD1353GE is a powerful, reliable and economical Generating Set Diesel Engine built on the dependable Volvo in-line six concept.

## Durability & low noise

Designed for easy, fast and economical installation. Field tested to ensure highest standard of durability and long life. Well-balanced to produce smooth and vibration-free operation with low noise level.

To maintain a controlled working temperature in cylinders and combustion chambers, the engine is equipped with piston cooling. The engine is also fitted with replaceable cylinder liners and valve seats/guides to ensure maximum durability and service life of the engine.

## Low exhaust emission

The state of the art, high-tech injection and highly efficient charge air system with low internal losses contributes to excellent combustion and low fuel consumption.

The TAD1353GE is EPA/CARB Tier 3 emission certified. These regulations are met by using V-ACT™ (Volvo Advanced Combustion technology).

V-ACT includes a flexible high pressure fuel injection system, an air management system including an internal exhaust gas recirculation device and an enhanced electronic controller.

## Easy service & maintenance

Easily accessible service and maintenance points contribute to the ease of service of the engine.

## Technical description

### Engine and block

- Cast iron cylinder block with optimum distribution of forces without the block being unnecessarily heavy.
- Wet, replaceable cylinder liners
- Piston cooling for low piston temperature and reduced ring temperature
- Tapered connecting rods for increased piston lifetime
- Crankshaft induction hardened bearing surfaces and fillets with seven bearings for moderate load on main and high-end bearings
- Case hardened and Nitrocarburized transmission gears for heavy duty operation
- Keystone top compression rings for long service life



## Features

- Excellent load acceptance
- High efficient cooling system (AOT 59 °C at Standby power)
- Optimized for 1800 rpm
- EMS 2
- EPA/CARB Tier 3 emission certified
- Wide range of optional equipment
- Compact design

- Viscous type crankshaft vibration dampers to withstand single bearing alternator torsional vibrations
- Replaceable valve guides and valve seats
- Over head camshaft and four valves per cylinder

### Lubrication system

- Full flow oil cooler
- Full flow disposable spin-on oil filter, for extra high filtration
- The lubricating oil level can be measured during operation
- Gear type lubricating oil pump, gear driven by the transmission

### Fuel system

- Electronic high pressure unit injectors
- Fuel prefilter with water separator and water-in-fuel indicator / alarm
- Gear driven low-pressure fuel pump
- Fine fuel filter with manual feed pump and fuel pressure switch

### Cooling system

- Efficient cooling with accurate coolant control through a water distribution duct in the cylinder block. Reliable sleeve thermostat with minimum pressure drop

- Belt driven coolant pump with high degree of efficiency

### Turbo charger

- Efficient and reliable turbo charger
- Electronically controlled Waste-gate
- Extra oil filter for the turbo charger

### Electrical system

- Engine Management System 2 (EMS 2), an electronically controlled processing system which optimizes engine performance. It also includes advanced facilities for diagnostics and fault tracing
- The instruments and controls connect to the engine via the CAN SAE J1939 interface, either through the Control Interface Unit (CIU) or the Digital Control Unit (DCU). The CIU converts the digital CAN bus signal to an analog signal, making it possible to connect a variety of instruments. The DCU is a control panel with display, engine control, monitoring, alarm, parameter setting and diagnostic functions. The DCU also presents error codes in clear text.
- Sensors for oil pressure, oil temp, boost pressure, boost temp, coolant temp, fuel temp, water in fuel, fuel pressure and two speed sensors.

**VOLVO  
PENTA**

# TAD1353GE

## Technical Data

### General

Engine designation .....	TAD1353GE
No. of cylinders and configuration .....	in-line 6
Method of operation .....	4-stroke
Bore, mm (in.) .....	131 (5.16)
Stroke, mm (in.) .....	158 (6.22)
Displacement, l (in <sup>3</sup> ) .....	12.78 (780)
Compression ratio .....	18.1:1
Dry weight, kg (lb) .....	1295 (2855)
Dry weight with Gen Pac, kg (lb) .....	1715 (3781)
Wet weight, kg (lb) .....	1325 (2921)
Wet weight ith Gen Pac, kg (lb) .....	1790 (3946)

### Performance

with fan, kW (hp) at:	<b>1800 rpm</b>
Prime Power	391 (532)
Standby Power	430 (585)

### Lubrication system

Oil consumption, liter/h (US gal/h) at:	<b>1800 rpm</b>
Prime Power	0.04 (0.011)
Standby Power	0.05 (0.013)
Oil system capacity incl filters, liter .....	36

### Fuel system

Specific fuel consumption at:	<b>1800 rpm</b>
Prime Power, g/kWh (lb/hph)	
25 %	250 (0.405)
50 %	219 (0.355)
75 %	210 (0.340)
100 %	201 (0.326)
Standby Power, g/kWh (lb/hph)	
25 %	247 (0.400)
50 %	215 (0.349)
75 %	209 (0.339)
100 %	200 (0.324)

### Intake and exhaust system

Air consumption, m <sup>3</sup> /min (cfm) at:	<b>1800 rpm</b>
Prime Power	29 (1038)
Standby Power	31 (1102)
Max allowable air intake restriction, kPa (PSI) .....	5 (0.7)
Heat rejection to exhaust, kW (BTU/min) at:	
Prime Power	306 (17402)
Standby Power	338 (19222)
Exhaust gas temperature after turbine, °C (°F) at:	
Prime Power	485 (905)
Standby Power	495 (923)
Max allowable back-pressure in exhaust line, kPa (PSI) .....	10 (1.5)
Exhaust gas flow, m <sup>3</sup> /min (cfm) at:	
Prime power	74.0 (2613)
Standby Power	79.0 (2790)

### Cooling system

Heat rejection radiation from engine, kW (BTU/min) at:	<b>1800 rpm</b>
Prime Power	10 (569)
Standby Power	11 (626)
Heat rejection to coolant kW (BTU/min) at:	
Prime Power	165 (9383)
Standby Power	178 (10123)
Fan power consumption, kW (hp)	19 (26)

## Standard equipment

### Engine

- Automatic belt tensioner
- Lift eyelets

### Flywheel

- Flywheel housing with conn. acc. to SAE 1
- Flywheel for 14" flex. plate and flexible coupling

### Engine suspension

- Fixed front suspension

### Lubrication system

- Oil dipstick
- Full-flow oil filter of spin-on type
- By-pass oil filter of spin-on type
- Oil cooler, side mounted
- Low noise oil sump

### Fuel system

- Fuel filters of disposable type
- Electronic unit injectors
- Pre-filter with water separator

### Intake and exhaust system

- Air filter with replaceable paper insert
- Air restriction indicator
- Air cooled exhaust manifold
- Connecting flange for exhaust pipe
- Exhaust flange
- Turbo charger, low right side

### Cooling system

- Radiator incl intercooler
- Coolant pump
- Fan hub
- Thrust fan
- Fan guard
- Belt guard

### Control system

- Engine Management System (EMS) with CAN-bus interface SAE J1939

### Alternator

- Alternator 80 A

### Starting system

- Starter motor
- Connection facility for extra starter motor

### Instruments and senders

- Temp.- and oil pressure for automatic stop/alarm

### Other equipment

- Expandable base frame

### Engine Packing

- Plastic wrapping

- <sup>1)</sup> must be ordered, see order specification
- optional equipment or not applicable
- included in standard specification

For our wide range of optional equipment, please see Order specification.

## Dimensions TAD1353GE

Not for installation

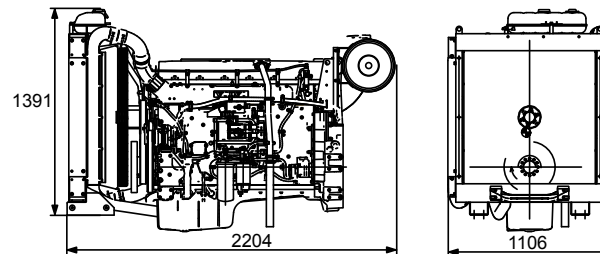

Note! Not all models, standard equipment and accessories are available in all countries. All specifications are subject to change without notice. The engine illustrated may not be entirely identical to production standard engines.

### Power Standards

The engine performance corresponds to ISO 3046, BS 5514 and DIN 6271. The technical data applies to an engine without cooling fan and operating on a fuel with calorific value of 42.7 MJ/kg (18360 BTU/lb) and a density of 0.84 kg/liter (7.01 lb/US gal), also where this involves a deviation from the standards. Power output guaranteed within 0 to +2% at rated ambient conditions at delivery. Ratings are based on ISO 8528. Engine speed governing in accordance with ISO 3046/IV, class A1 and ISO 8528-5 class G3

### Exhaust emissions

The engine complies with EU stage 3 emission legislation according to the Non Road Directive EU 97/68/EEC. The engine also complies with TA-luft -50% exhaust emission regulations.

### Rating Guidelines

PRIME POWER rating corresponds to ISO Standard Power for continuous operation. It is applicable for supplying electrical power at variable load for an unlimited number of hours instead of commercially purchased power. A10 % overload capability for governing purpose is available for this rating. STANDBY POWER rating corresponds to ISO Standard Fuel Stop Power. It is applicable for supplying standby electrical power at variable load in areas with well established electrical networks in the event of normal utility power failure. No overload capability is available for this rating. 1 hp = 1 kW x 1.36

# VOLVO PENTA

AB Volvo Penta  
SE-405 08 Göteborg, Sweden  
www.volvopenta.com

## S4L1D-G41 Wdg.311 - Technical Data Sheet

### Standards

Stamford industrial alternators meet the requirements of the relevant parts of the BS EN 60034 and the relevant section of other international standards such as BS5000, VDE 0530, NEMA MG1-32, IEC34, CSA C22.2-100 and AS1359. Other standards and certifications can be considered on request.

### Quality Assurance

Alternators are manufactured using production procedures having a quality assurance level to BS EN ISO 9001.



### Excitation and Voltage Regulators

Excitation System					
<b>AVR Type</b>	AS440	MX341	MX321		
<b>Voltage Regulation</b>	± 1%	± 1%	± 0.5%		with 4% Engine Governing
<b>AVR Power</b>	Self-Excited	PMG	PMG		

<b>No Load Excitation Voltage (V)</b>	12-10
<b>No Load Excitation Current (A)</b>	0.7-0.6
<b>Full Load Excitation Voltage (V)</b>	48-45
<b>Full Load Excitation Current (A)</b>	2.6-2.4
<b>Exciter Time Constant (seconds)</b>	0.105

# STAMFORD

## S4L1D-G41 Wdg.311

Electrical Data								
Insulation System	Class H							
Stator Winding	Double Layer Lap							
Winding Pitch	Two Thirds							
Winding Leads	12							
Winding Number	311							
Number of Poles	4							
IP Rating	IP23							
RFI Suppression	BS EN 61000-6-2 & BS EN 61000-6-4, VDE 0875G, VDE 0875N. Refer to factory for others							
Waveform Distortion	NO LOAD < 1.5% NON-DISTORTING BALANCED LINEAR LOAD < 5.0%							
Short Circuit Ratio	1/Xd							
Steady State X/R Ratio	15.8292							
	50 Hz				60 Hz			
Telephone Interference	THF<2%				TIF<50			
Cooling Air	0.78 m³/sec				0.94 m³/sec			
Voltage Star	380	400	415	440	416	440	460	480
kVA Base Rating (Class H) for Reactance Values	430	450	450	430	500	535	540	560
Saturated Values in Per Unit at Base Ratings and Voltages								
Xd Dir. Axis Synchronous	3.39	3.20	2.97	2.53	3.96	3.79	3.50	3.33
X'd Dir. Axis Transient	0.18	0.17	0.16	0.13	0.20	0.19	0.18	0.17
X''d Dir. Axis Subtransient	0.11	0.10	0.09	0.08	0.13	0.12	0.11	0.11
Xq Quad. Axis Reactance	2.63	2.48	2.31	1.96	3.07	2.93	2.71	2.58
X''q Quad. Axis Subtransient	0.32	0.30	0.28	0.24	0.37	0.36	0.33	0.31
XL Stator Leakage Reactance	0.09	0.09	0.08	0.07	0.10	0.10	0.09	0.09
X2 Negative Sequence Reactance	0.19	0.18	0.17	0.15	0.22	0.21	0.19	0.19
X0 Zero Sequence Reactance	0.03	0.03	0.02	0.02	0.03	0.03	0.03	0.02
Unsaturated Values in Per Unit at Base Ratings and Voltages								
Xd Dir. Axis Synchronous	4.07	3.84	3.57	3.03	4.75	4.54	4.20	4.00
X'd Dir. Axis Transient	0.20	0.19	0.18	0.15	0.23	0.22	0.20	0.19
X''d Dir. Axis Subtransient	0.13	0.12	0.11	0.09	0.15	0.14	0.13	0.13
Xq Quad. Axis Reactance	2.71	2.56	2.38	2.02	3.16	3.02	2.79	2.66
X''q Quad. Axis Subtransient	0.38	0.36	0.34	0.29	0.45	0.43	0.39	0.38
XL Stator Leakage Reactance	0.10	0.10	0.09	0.08	0.12	0.11	0.10	0.10
Xlr Rotor Leakage Reactance	0.11	0.11	0.10	0.09	0.13	0.13	0.12	0.11
X2 Negative Sequence Reactance	0.23	0.22	0.21	0.17	0.26	0.25	0.23	0.22
X0 Zero Sequence Reactance	0.03	0.03	0.03	0.02	0.03	0.03	0.03	0.03



# STAMFORD®

## S4L1D-G41 Wdg.311

Time Constants (Seconds)		
T'd TRANSIENT TIME CONST.	0.068	
T" d SUB-TRANSTIME CONST.	0.014	
T'do O.C. FIELD TIME CONST.	2.1	
Ta ARMATURE TIME CONST.	0.016	
T"q SUB-TRANSTIME CONST.	0.0092	
Resistances in Ohms ( $\Omega$ ) at 22°C		
Stator Winding Resistance (Ra), per phase for series connected	0.0066	
Rotor Winding Resistance (Rf)	1.44	
Exciter Stator Winding Resistance	18	
Exciter Rotor Winding Resistance per phase	0.068	
PMG Phase Resistance (Rpmg) per phase	1.9	
Positive Sequence Resistance (R1)	0.00825	
Negative Sequence Resistance (R2)	0.009504	
Zero Sequence Resistance (R0)	0.00825	
Saturation Factors	400V	480V
SG1.0	0.24	0.24
SG1.2	0.99	0.99
Mechanical Data		
Shaft and Keys	All alternator rotors are dynamically balanced to better than BS6861: Part 1 Grade 2.5 for minimum vibration in operation. Two bearing generators are balanced with a half key.	
	1 Bearing	2 Bearings
SAE Adaptor	SAE 0.5, 1	N/A
Moment of Inertia	5.6754kgm <sup>2</sup>	N/A
Weight Wound Stator	561kg	N/A
Weight Wound Rotor	482kg	N/A
Weight Complete Alternator	1190kg	N/A
Shipping weight in a Crate	1260kg	N/A
Packing Crate Size	155 x 87 x 107 (cm)	N/A
Maximum Over Speed	2250 RPM for two minutes	
Bearing Drive End	N/A	N/A
Bearing Non-Drive End	Ball 6314	N/A

# STAMFORD®

## S4L1D-G41 Wdg.311

### THREE PHASE EFFICIENCY CURVES

50Hz

60Hz

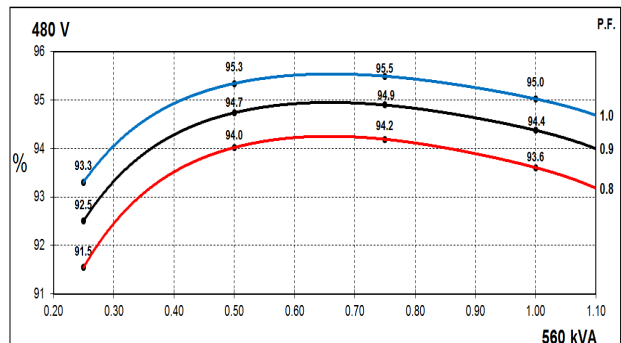
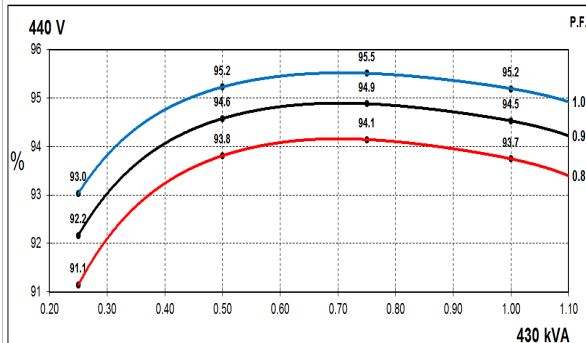
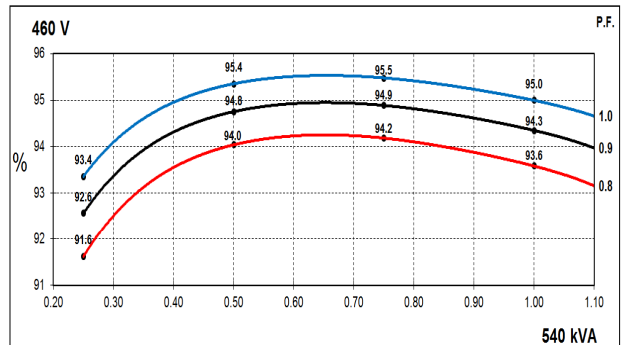
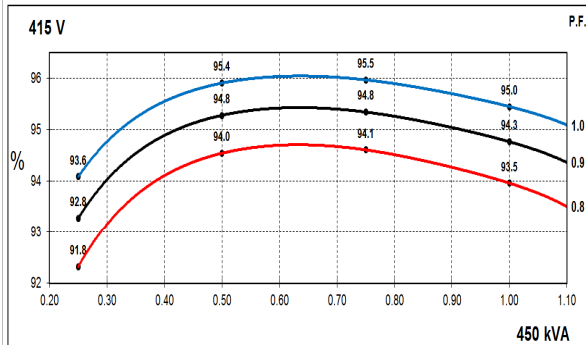
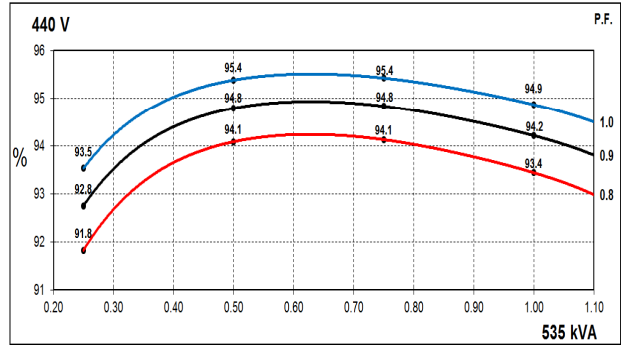
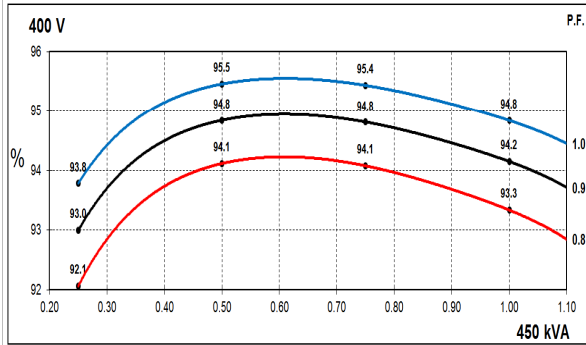
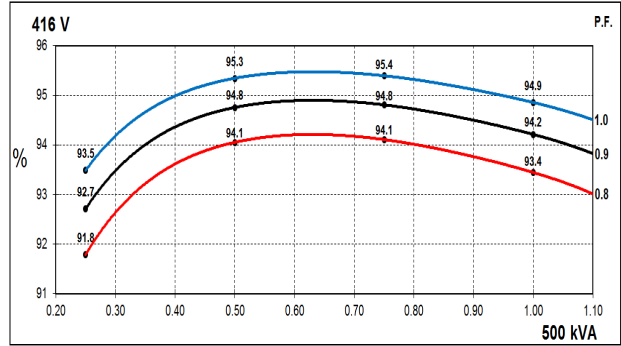
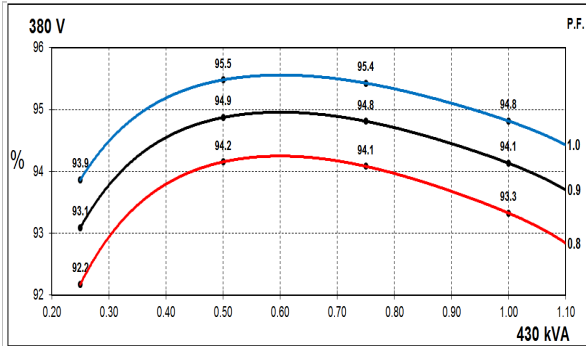

# STAMFORD

S4L1D-G41 Wdg.311

## Locked Rotor Motor Starting Curves - Separately Excited

**50Hz**

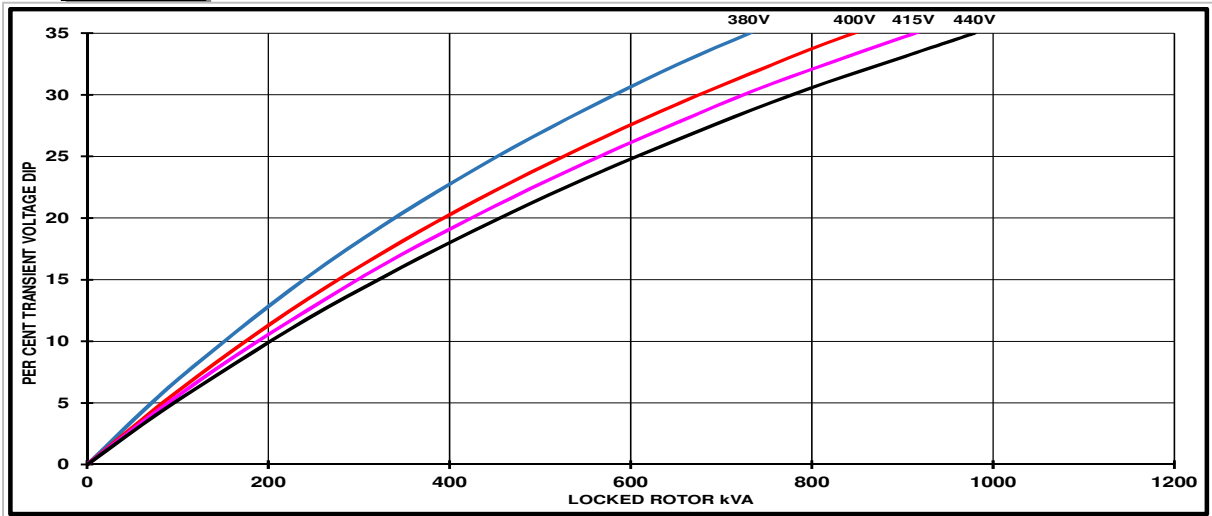

**60Hz**

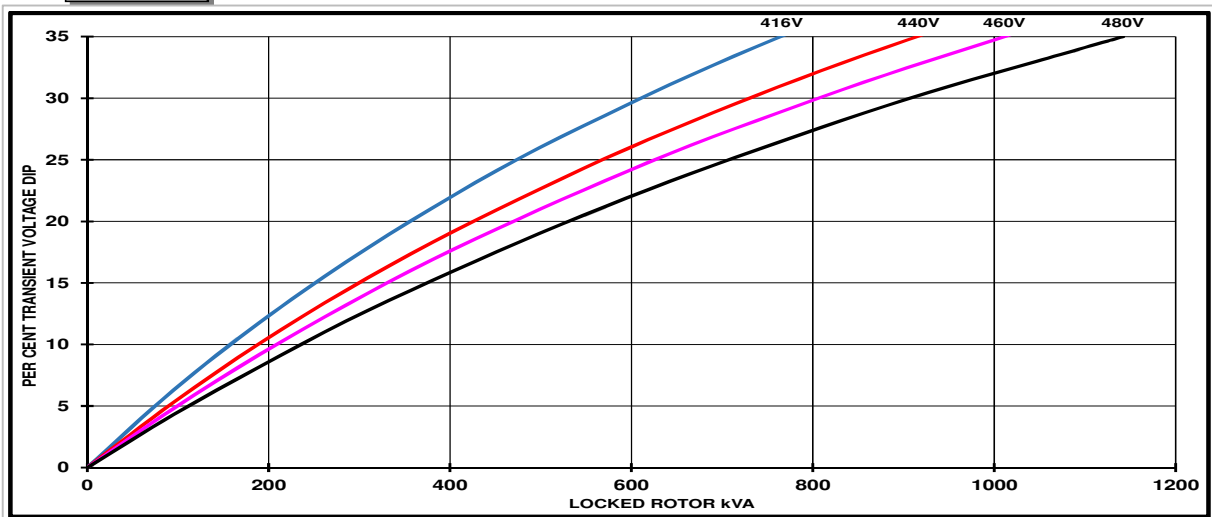

Transient Voltage Dip Scaling Factor		Transient Voltage Rise Scaling Factor
PF	Factor	For voltage rise multiply voltage dip by 1.25
< 0.5	1	
0.5	0.97	
0.6	0.93	
0.7	0.9	
0.8	0.85	
0.9	0.83	

# STAMFORD

S4L1D-G41 Wdg.311

## Locked Rotor Motor Starting Curves - Self Excited

**50Hz**

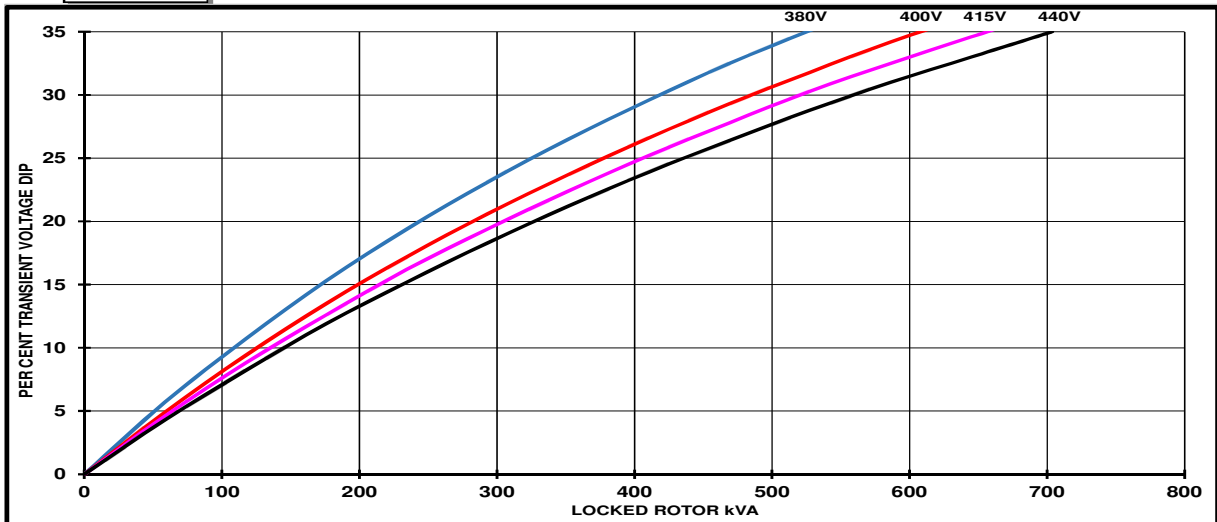

**60Hz**

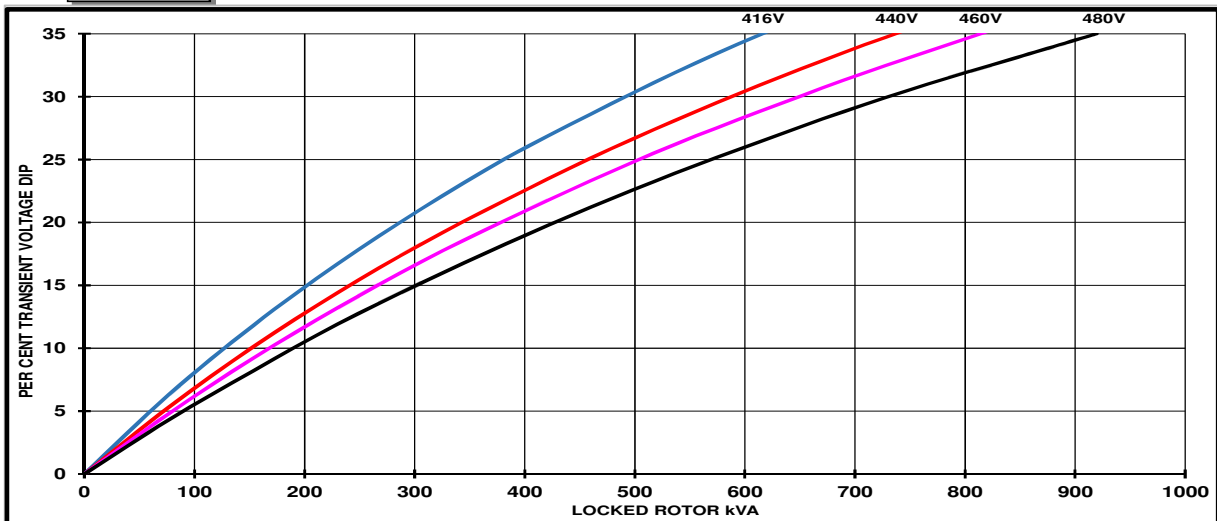

Transient Voltage Dip Scaling Factor		Transient Voltage Rise Scaling Factor
PF	Factor	
< 0.5	1	For voltage rise multiply voltage dip by 1.25
0.5	0.97	
0.6	0.93	
0.7	0.9	
0.8	0.85	
0.9	0.83	

# STAMFORD®

## S4L1D-G41 Wdg.311

### Three-phase Short Circuit Decrement Curve

**50Hz**

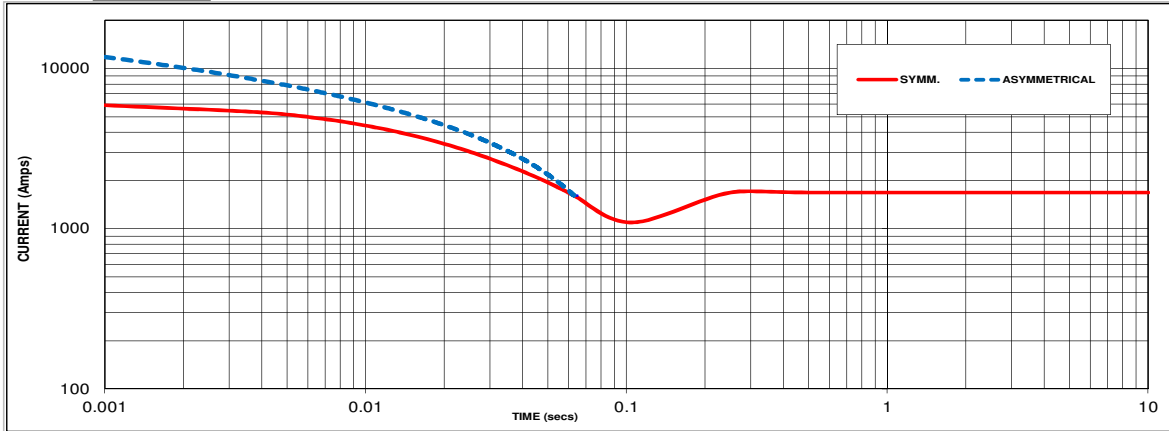

Sustained Short Circuit = 1680 Amps

**60Hz**

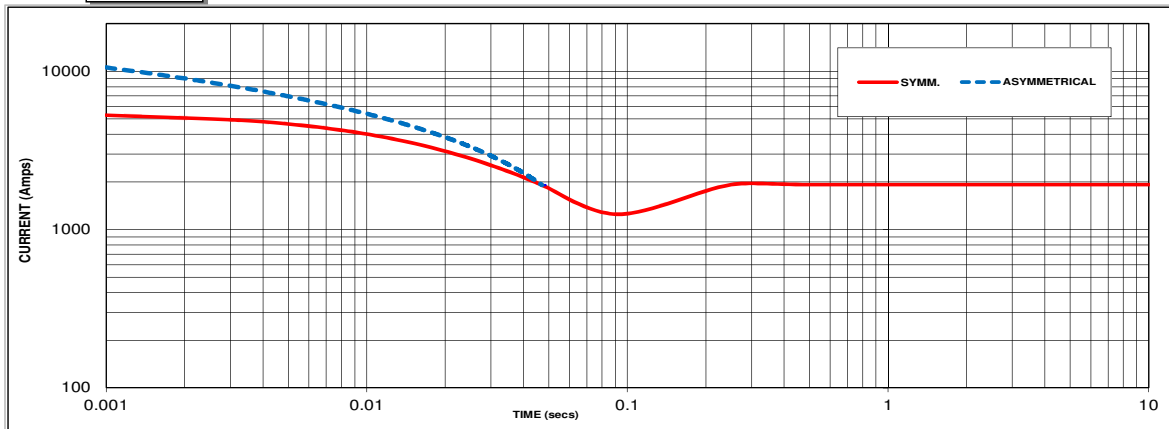

Sustained Short Circuit = 1920 Amps

**Note 1**

The following multiplication factors should be used to adjust the values from curve between time 0.001 seconds and the minimum current point in respect of nominal operating voltage :

50Hz		60Hz	
Voltage	Factor	Voltage	Factor
380V	X 1.00	416V	X 1.00
400V	X 1.05	440V	X 1.06
415V	X 1.09	460V	X 1.10
440V	X 1.16	480V	X 1.15

The sustained current value is constant irrespective of voltage level

**Note 2**

The following multiplication factor should be used to convert the values calculated in accordance with NOTE 1 to those applicable to the various types of short circuit :

	3-phase	2-phase L-L	1-phase L-N
Instantaneous	x 1.00	x 0.87	x 1.30
Minimum	x 1.00	x 1.80	x 3.20
Sustained	x 1.00	x 1.50	x 2.50
Max. sustained duration	10 sec.	5 sec.	2 sec.

All other times are unchanged

**Note 3**

Curves are drawn for Star connected machines under no-load excitation at rated speeds. For other connection the following multipliers should be applied to current values as shown :  
 Parallel Star = Curve current value X 2  
 Series Delta = Curve current value X 1.732



# STAMFORD

S4L1D-G41 Wdg.311

## Typical Alternator Operating Charts

**400V/50Hz**

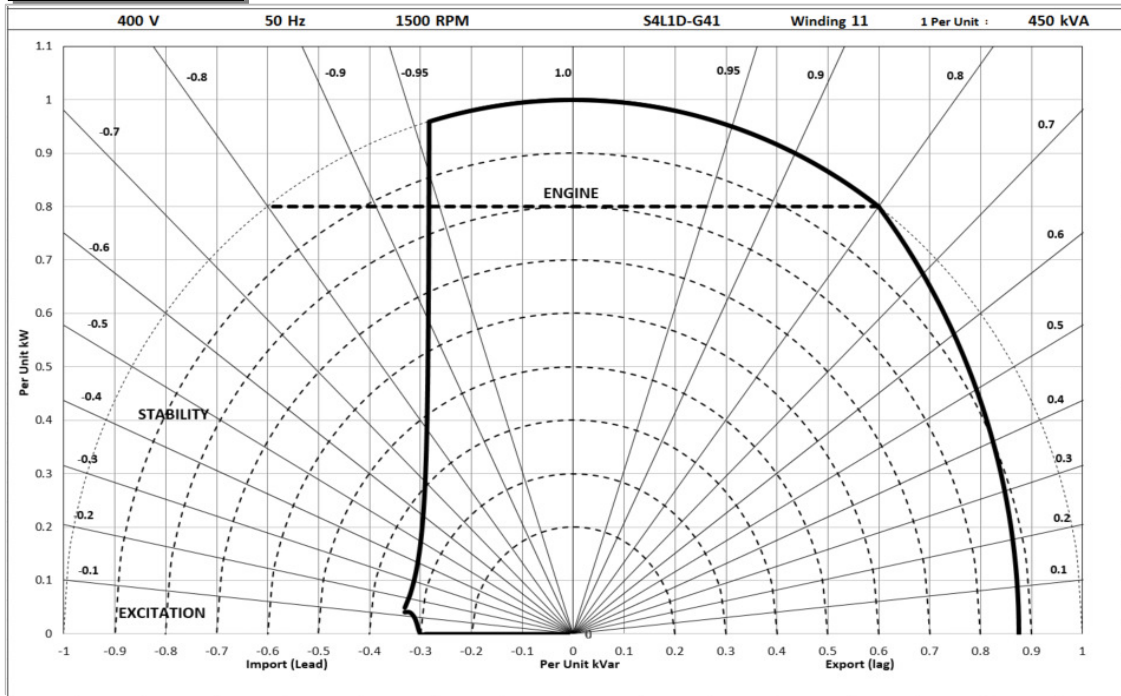

**480V/60Hz**

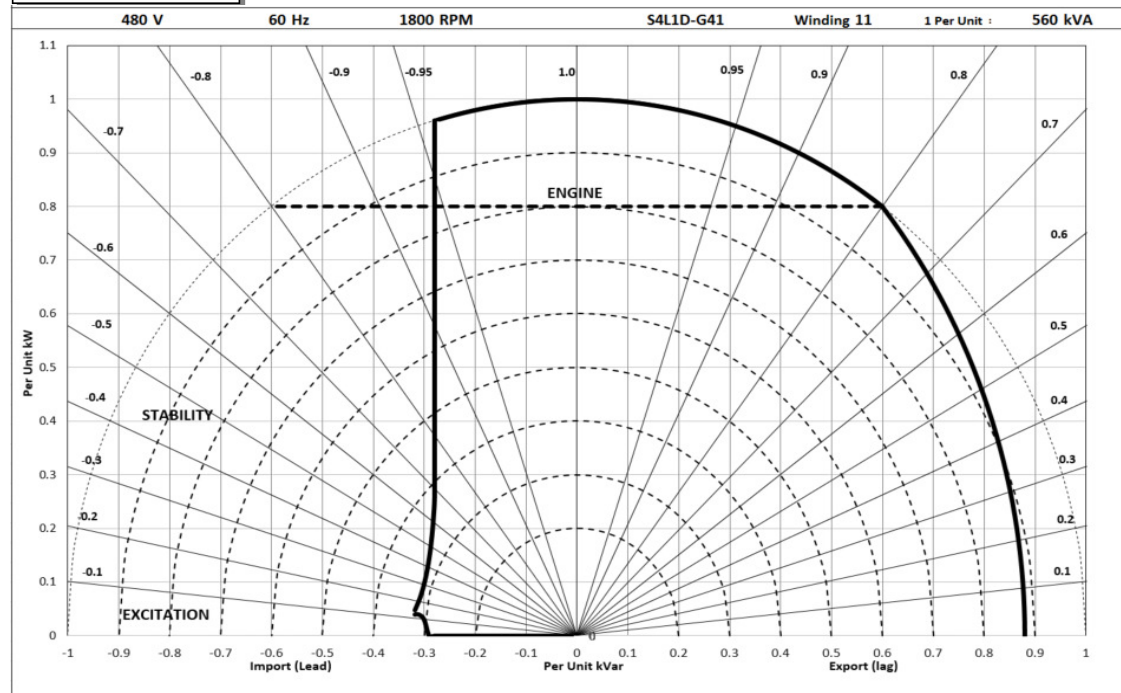

# STAMFORD®

## S4L1D-G41 Wdg.311

### RATINGS AT 0.8 POWER FACTOR

Class - Temp Rise		Standby - 163/27°C				Standby - 150/40°C				Cont. H - 125/40°C				Cont. F - 105/40°C			
<b>50 Hz</b>	Series Star (V)	380	400	415	440	380	400	415	440	380	400	415	440	380	400	415	440
	kVA	475	500	500	475	455	480	480	455	430	450	450	430	390	410	410	390
	kW	380	400	400	380	364	384	384	364	344	360	360	344	312	328	328	312
	Efficiency (%)	92.9	92.8	93.0	93.4	93.1	93.0	93.2	93.6	93.3	93.3	93.5	93.7	93.7	93.7	93.8	94.0
	kW Input	409	431	430	407	391	413	412	389	369	386	385	367	333	350	350	332

<b>60 Hz</b>	Series Star (V)	416	440	460	480	416	440	460	480	416	440	460	480	416	440	460	480
	kVA	565	600	600	625	535	575	575	600	500	535	540	560	455	485	490	510
	kW	452	480	480	500	428	460	460	480	400	428	432	448	364	388	392	408
	Efficiency (%)	92.9	92.9	93.1	93.1	93.2	93.1	93.3	93.3	93.4	93.4	93.6	93.6	93.7	93.8	93.9	93.9
	kW Input	487	517	515	537	459	494	493	514	428	458	462	479	388	414	418	435

#### De-Rates

All values tabulated above are subject to the following reductions:

- 5% when air inlet filters are fitted
- 3% for every 500 meters by which the operating altitude exceeds 1000 meters above mean sea level
- 3% for every 5°C by which the operational ambient temperature exceeds 40°C
- For any other operating conditions impacting the cooling circuit please refer to applications

Note: Requirement for operating in an ambient exceeding 60°C and altitude exceeding 4000 meters must be referred to applications.

#### Dimensional and Torsional Drawing

For dimensional and torsional information please refer to the alternator General Arrangement and rotor drawings available on our website (<http://stamford-avk.com/>)

**Note:** Continuous development of our products means that the information contained in our data sheets can change without notice, and specifications should always be confirmed with Cummins Generator Technologies prior to purchase.



Follow us @stamfordavk



Cummins Generator Technologies



View our videos at [youtube.com/stamfordavk](https://youtube.com/stamfordavk)

**[news.stamford-avk.com](https://news.stamford-avk.com)**

**For Applications Support:  
[applications@cummins.com](mailto:applications@cummins.com)**

**For Customer Service:  
[service-engineers@stamford-avk.com](mailto:service-engineers@stamford-avk.com)**

**For General Enquiries:  
[info@cumminsgeneratortechnologies.com](mailto:info@cumminsgeneratortechnologies.com)**

Copyright 2016. Cummins Generator Technologies Ltd. All rights reserved.  
Cummins and the Cummins logo are registered trade marks of Cummins Inc.  
STAMFORD is a registered trade mark of Cummins Generator Technologies Ltd.



## S4L1D-F41 Wdg.311 - Technical Data Sheet

### Standards

Stamford industrial alternators meet the requirements of the relevant parts of the BS EN 60034 and the relevant section of other international standards such as BS5000, VDE 0530, NEMA MG1-32, IEC34, CSA C22.2-100 and AS1359. Other standards and certifications can be considered on request.

### Quality Assurance

Alternators are manufactured using production procedures having a quality assurance level to BS EN ISO 9001.

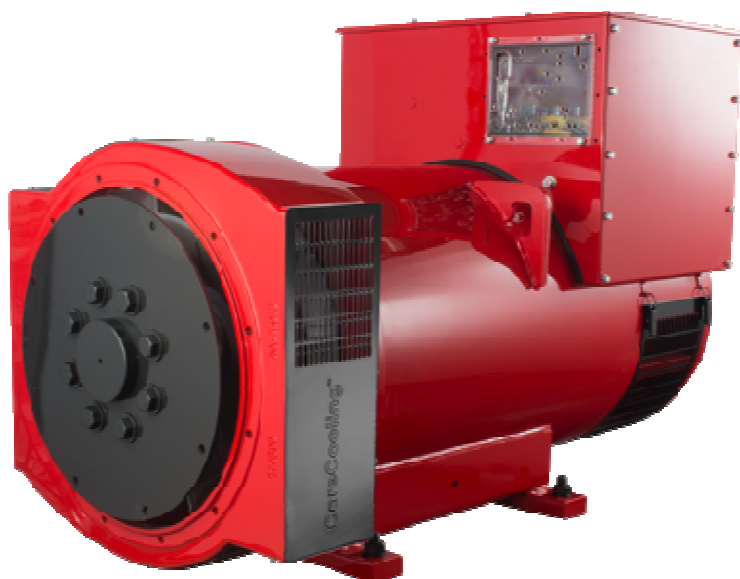

### Excitation and Voltage Regulators

Excitation System					
<b>AVR Type</b>	AS440	MX341	MX321		
<b>Voltage Regulation</b>	± 1%	± 1%	± 0.5%		with 4% Engine Governing
<b>Excitation Type</b>	Self-Excited	PMG	PMG		

<b>No Load Excitation Voltage (V)</b>	10 - 8
<b>No Load Excitation Current (A)</b>	0.7 - 0.5
<b>Full Load Excitation Voltage (V)</b>	41 - 37.5
<b>Full Load Excitation Current (A)</b>	2.3 - 2.1
<b>Exciter Time Constant (seconds)</b>	0.105

# STAMFORD

## S4L1D-F41 Wdg.311

Electrical Data								
Insulation System	Class H							
Stator Winding	Double Layer Lap							
Winding Pitch	Two Thirds							
Winding Leads	12							
Winding Number	311							
Number of Poles	4							
IP Rating	IP23							
RFI Suppression	BS EN 61000-6-2 & BS EN 61000-6-4, VDE 0875G, VDE 0875N. Refer to factory for others							
Waveform Distortion	NO LOAD < 1.5% NON-DISTORTING BALANCED LINEAR LOAD < 5.0%							
Short Circuit Ratio	1/Xd							
Steady State X/R Ratio	13.7389							
	50 Hz				60 Hz			
Telephone Interference	THF<2%				TIF<50			
Cooling Air	0.76 m <sup>3</sup> /sec				0.92 m <sup>3</sup> /sec			
Voltage Star	380	400	415	440	416	440	460	480
kVA Base Rating (Class H) for Reactance Values	400	415	415	400	455	500	500	520
Saturated Values in Per Unit at Base Ratings and Voltages								
Xd Dir. Axis Synchronous	2.71	2.54	2.36	2.02	3.28	3.23	2.95	2.82
X'd Dir. Axis Transient	0.18	0.17	0.16	0.13	0.18	0.18	0.16	0.16
X''d Dir. Axis Subtransient	0.13	0.13	0.12	0.10	0.13	0.13	0.12	0.11
Xq Quad. Axis Reactance	2.34	2.19	2.03	1.74	2.90	2.84	2.60	2.49
X''q Quad. Axis Subtransient	0.31	0.29	0.27	0.23	0.42	0.42	0.38	0.36
XL Stator Leakage Reactance	0.06	0.05	0.05	0.04	0.07	0.07	0.07	0.06
X2 Negative Sequence Reactance	0.22	0.21	0.20	0.17	0.29	0.29	0.26	0.25
X0 Zero Sequence Reactance	0.09	0.08	0.08	0.07	0.10	0.10	0.09	0.08
Unsaturated Values in Per Unit at Base Ratings and Voltages								
Xd Dir. Axis Synchronous	3.26	3.05	2.83	2.43	3.94	3.87	3.54	3.38
X'd Dir. Axis Transient	0.21	0.19	0.18	0.15	0.21	0.21	0.19	0.18
X''d Dir. Axis Subtransient	0.16	0.15	0.14	0.12	0.16	0.15	0.14	0.13
Xq Quad. Axis Reactance	2.41	2.26	2.10	1.80	2.98	2.93	2.68	2.56
X''q Quad. Axis Subtransient	0.37	0.35	0.32	0.28	0.51	0.50	0.46	0.44
XL Stator Leakage Reactance	0.06	0.06	0.05	0.05	0.08	0.08	0.07	0.07
Xlr Rotor Leakage Reactance	0.10	0.09	0.09	0.07	0.11	0.11	0.10	0.10
X2 Negative Sequence Reactance	0.27	0.25	0.23	0.20	0.35	0.34	0.31	0.30
X0 Zero Sequence Reactance	0.10	0.10	0.09	0.08	0.11	0.11	0.10	0.10



# STAMFORD®

## S4L1D-F41 Wdg.311

Time Constants (Seconds)		
T'd TRANSIENT TIME CONST.	0.08	
T''d SUB-TRANSTIME CONST.	0.019	
T'do O.C. FIELD TIME CONST.	1.7	
Ta ARMATURE TIME CONST.	0.018	
T''q SUB-TRANSTIME CONST.	0.009	
Resistances in Ohms ( $\Omega$ ) at 22°C		
Stator Winding Resistance (Ra), per phase for series connected	0.0073	
Rotor Winding Resistance (Rf)	1.37	
Exciter Stator Winding Resistance	18	
Exciter Rotor Winding Resistance per phase	0.068	
PMG Phase Resistance (Rpmg) per phase	1.9	
Positive Sequence Resistance (R1)	0.009125	
Negative Sequence Resistance (R2)	0.010512	
Zero Sequence Resistance (R0)	0.009125	
Saturation Factors	400V	480V
SG1.0	0.36	0.38
SG1.2	1.46	1.52
Mechanical Data		
Shaft and Keys	All alternator rotors are dynamically balanced to better than BS6861: Part 1 Grade 2.5 for minimum vibration in operation. Two bearing generators are balanced with a half key.	
	1 Bearing	2 Bearings
SAE Adaptor	SAE 0.5, 1	N/A
Moment of Inertia	5.4292kgm <sup>2</sup>	N/A
Weight Wound Stator	535kg	N/A
Weight Wound Rotor	463kg	N/A
Weight Complete Alternator	1160kg	N/A
Shipping weight in a Crate	1230kg	N/A
Packing Crate Size	155 x 87 x 107 (cm)	N/A
Maximum Over Speed	2250 RPM for two minutes	
Bearing Drive End	N/A	N/A
Bearing Non-Drive End	Ball 6314	N/A

# STAMFORD®

## S4L1D-F41 Wdg.311

### THREE PHASE EFFICIENCY CURVES

50Hz

60Hz

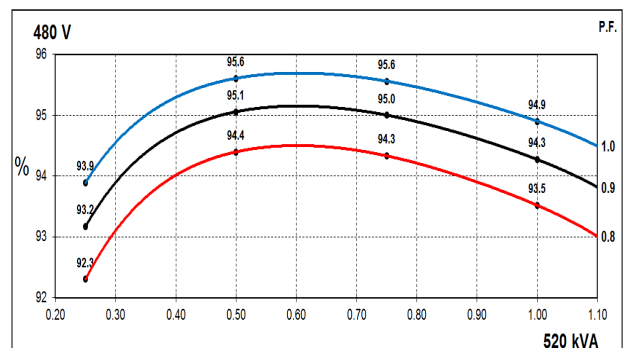
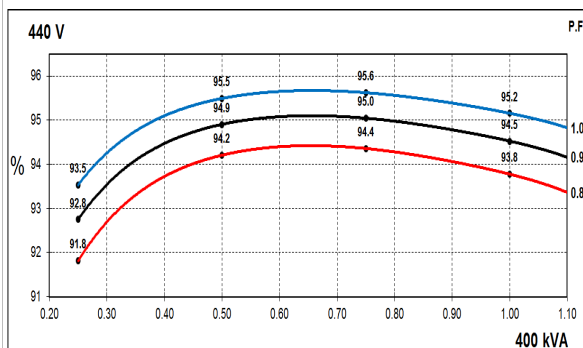
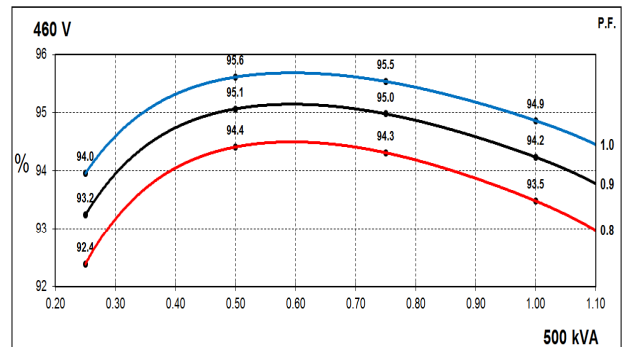
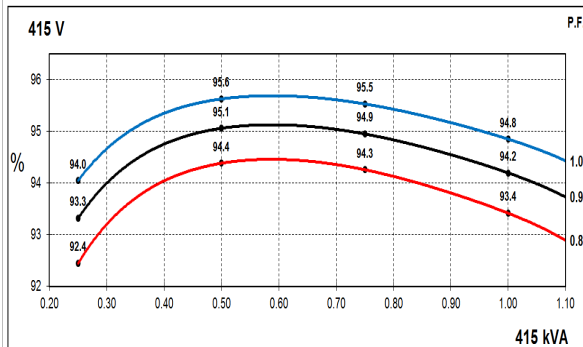
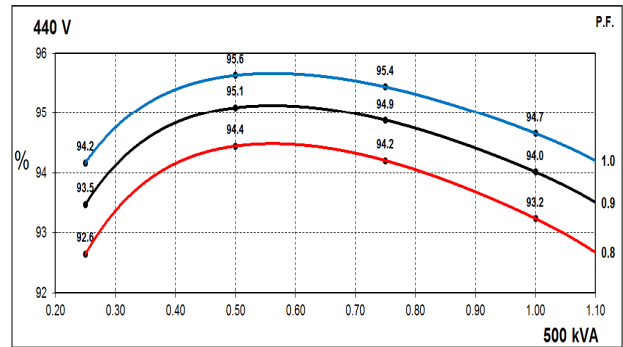
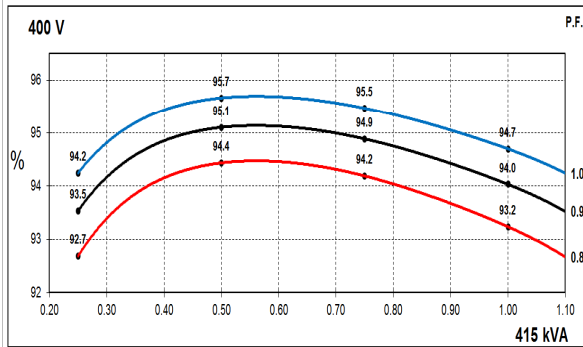
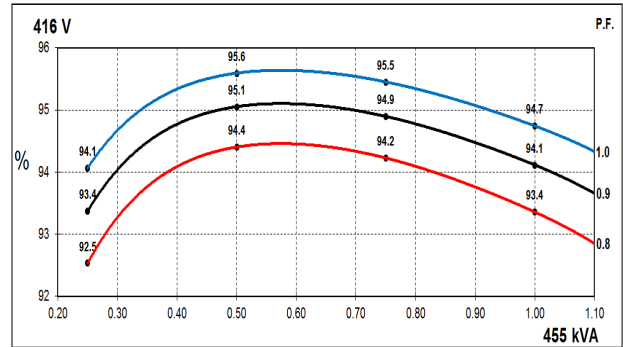
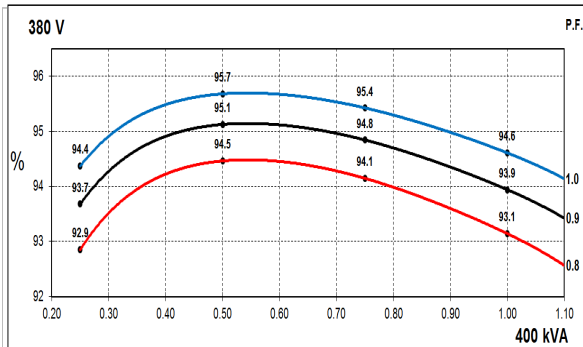

# STAMFORD

S4L1D-F41 Wdg.311

## Locked Rotor Motor Starting Curves - Separately Excited

**50Hz**

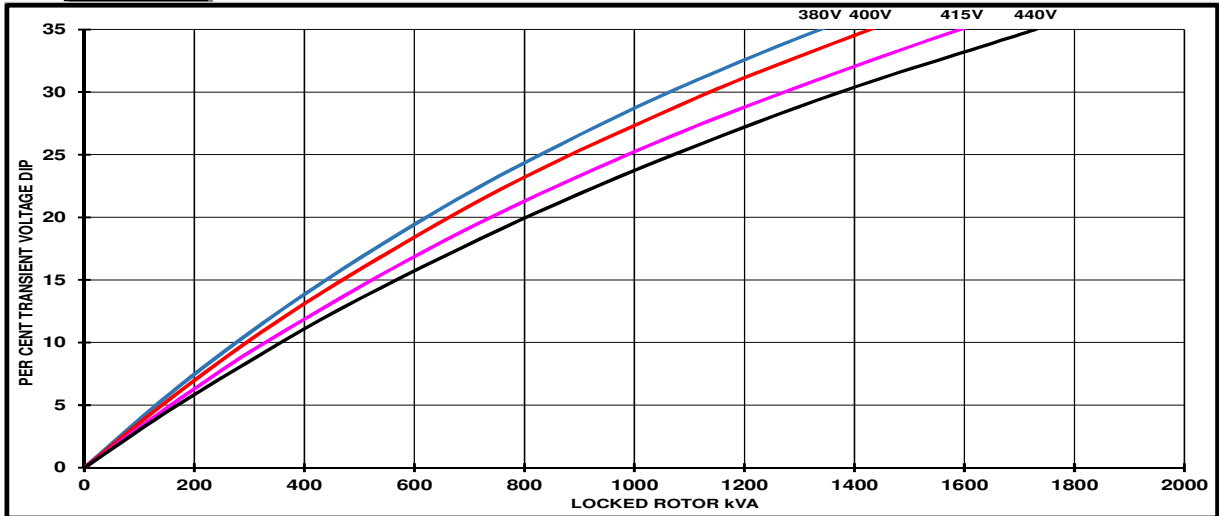

**60Hz**

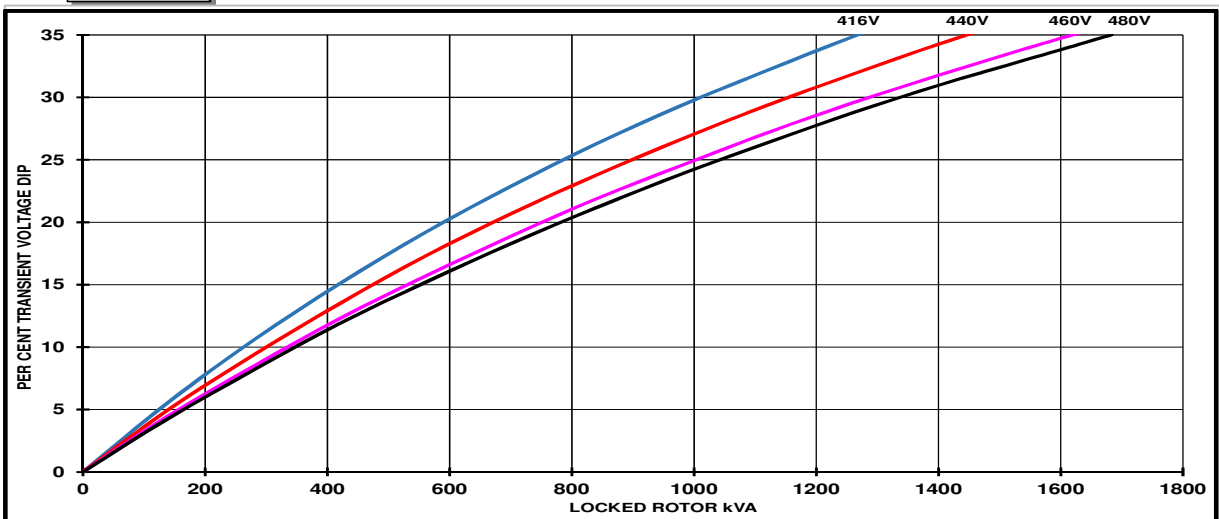

Transient Voltage Dip Scaling Factor		Transient Voltage Rise Scaling Factor
PF	Factor	
< 0.5	1	For voltage rise multiply voltage dip by 1.25
0.5	0.97	
0.6	0.93	
0.7	0.9	
0.8	0.85	
0.9	0.83	

# STAMFORD

S4L1D-F41 Wdg.311

## Locked Rotor Motor Starting Curves - Self Excited

**50Hz**

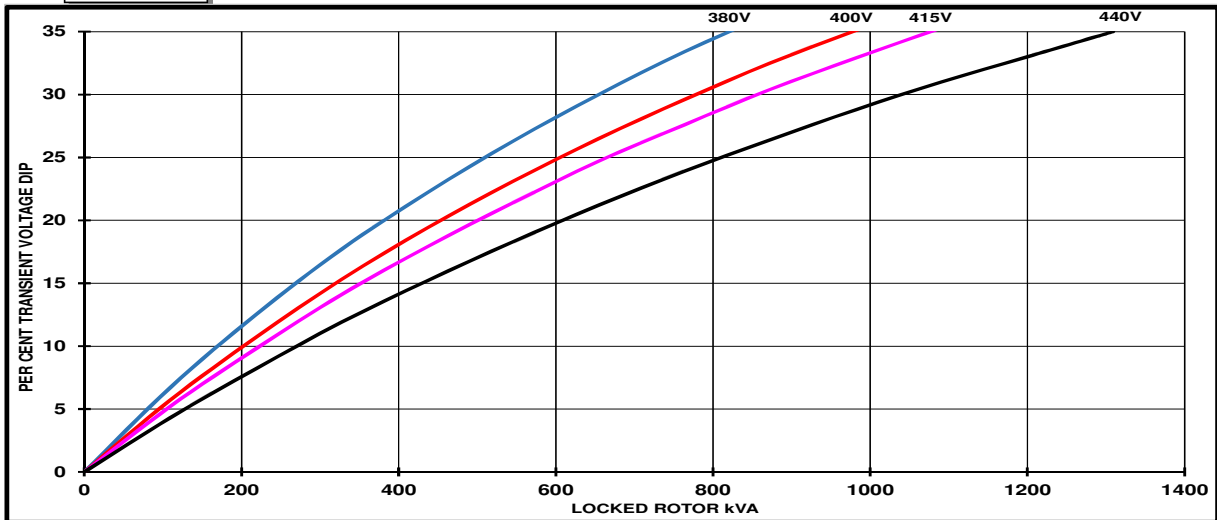

**60Hz**

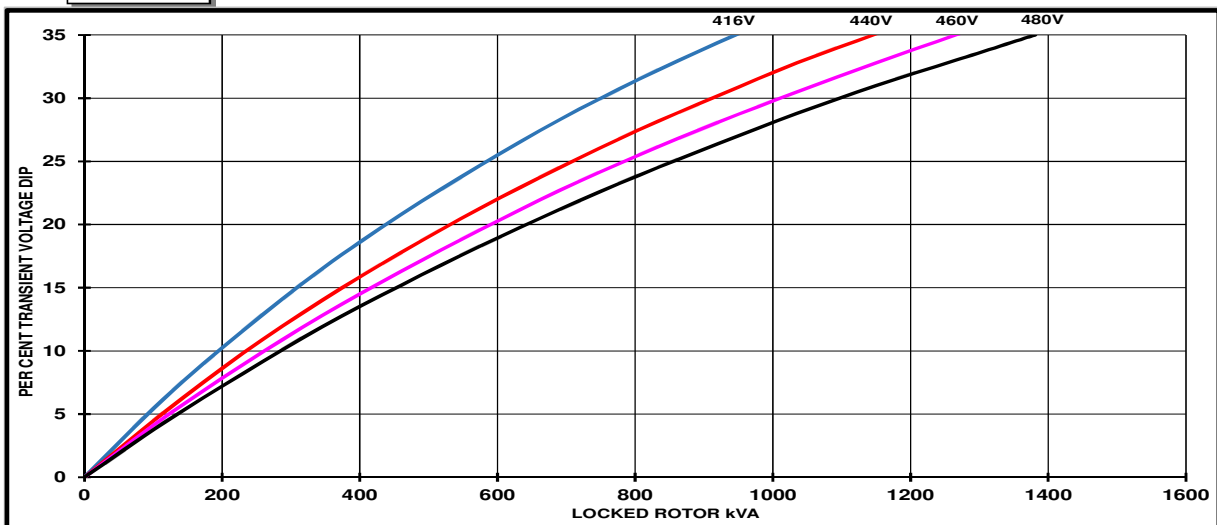

Transient Voltage Dip Scaling Factor		Transient Voltage Rise Scaling Factor
PF	Factor	
< 0.5	1	For voltage rise multiply voltage dip by 1.25
0.5	0.97	
0.6	0.93	
0.7	0.9	
0.8	0.85	
0.9	0.83	

# STAMFORD

S4L1D-F41 Wdg.311

## Three-phase Short Circuit Decrement Curve

**50Hz**

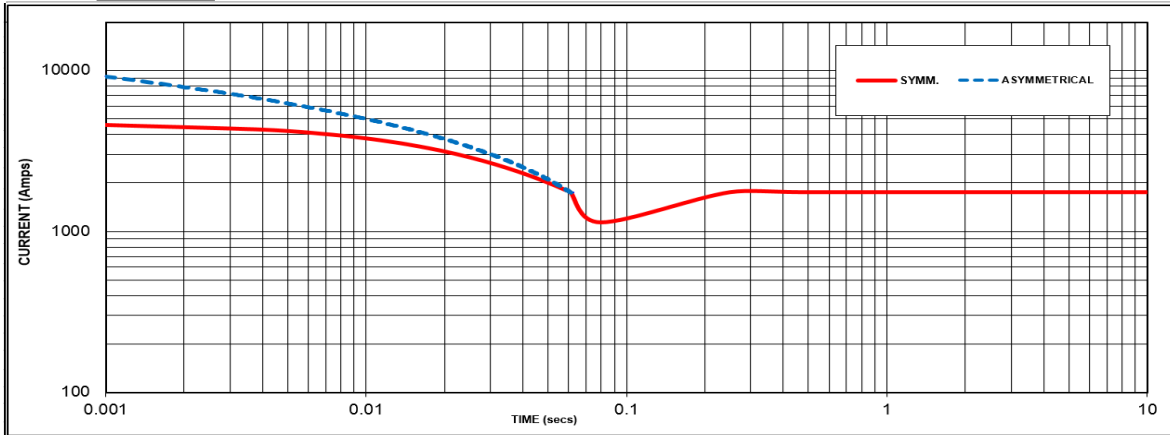

Sustained Short Circuit = 1750 Amps

**60Hz**

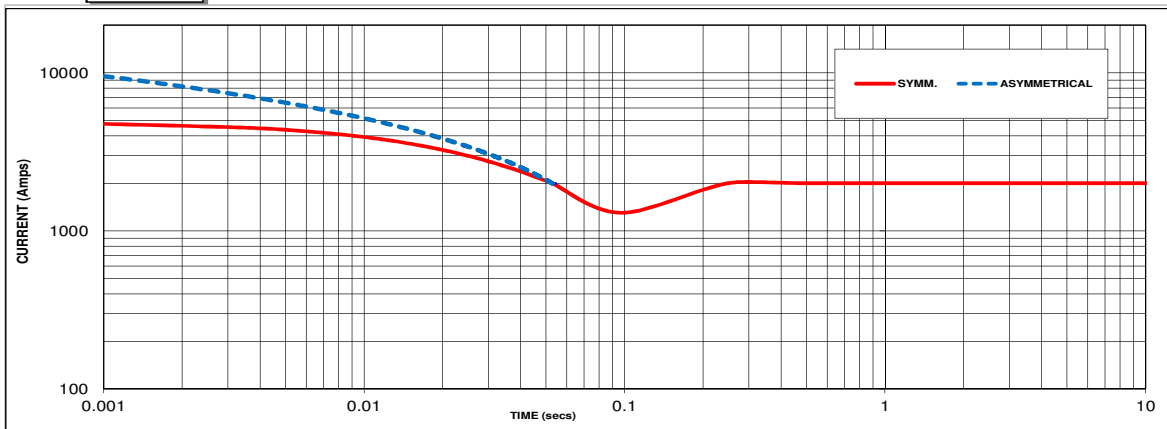

Sustained Short Circuit = 2000 Amps

**Note 1**

The following multiplication factors should be used to adjust the values from curve between time 0.001 seconds and the minimum current point in respect of nominal operating voltage :

50Hz		60Hz	
Voltage	Factor	Voltage	Factor
380V	X 1.00	416V	X 1.00
400V	X 1.05	440V	X 1.06
415V	X 1.09	460V	X 1.10
440V	X 1.16	480V	X 1.15

The sustained current value is constant irrespective of voltage level

**Note 2**

The following multiplication factor should be used to convert the values calculated in accordance with NOTE 1 to those applicable to the various types of short circuit :

	3-phase	2-phase L-L	1-phase L-N
Instantaneous	x 1.00	x 0.87	x 1.30
Minimum	x 1.00	x 1.80	x 3.20
Sustained	x 1.00	x 1.50	x 2.50
Max. sustained duration	10 sec.	5 sec.	2 sec.

All other times are unchanged

**Note 3**

Curves are drawn for Star connected machines under no-load excitation at rated speeds. For other connection the following multipliers should be applied to current values as shown :  
 Parallel Star = Curve current value X 2  
 Series Delta = Curve current value X 1.732



# STAMFORD

S4L1D-F41 Wdg.311

## Typical Alternator Operating Charts

**400V/50Hz**

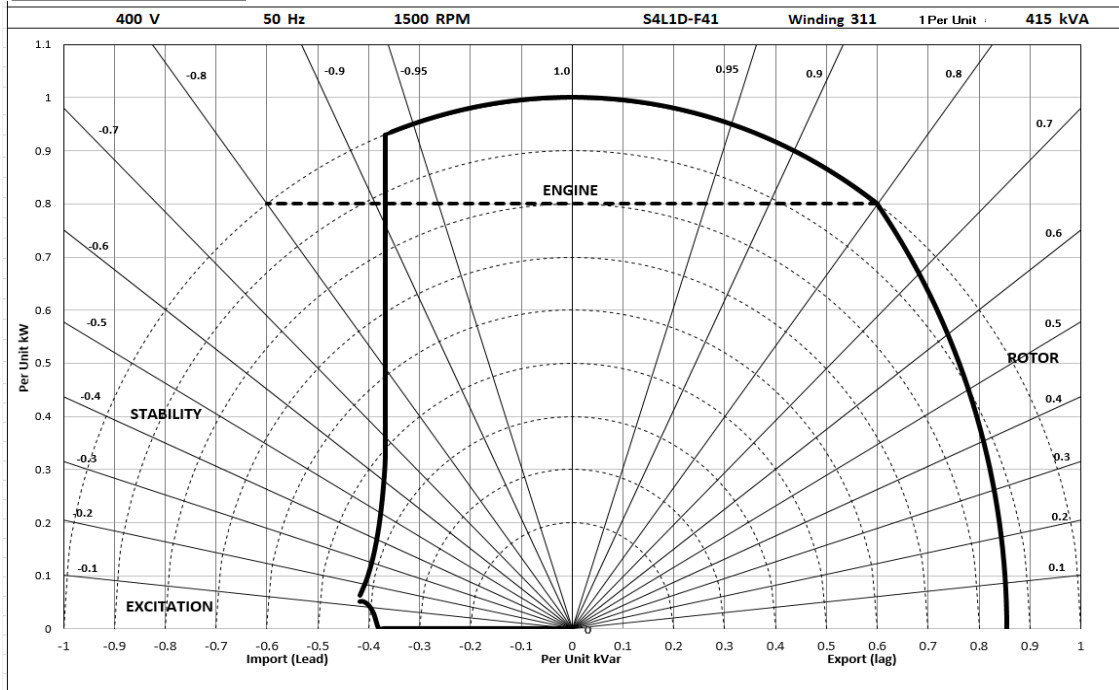

**480V/60Hz**

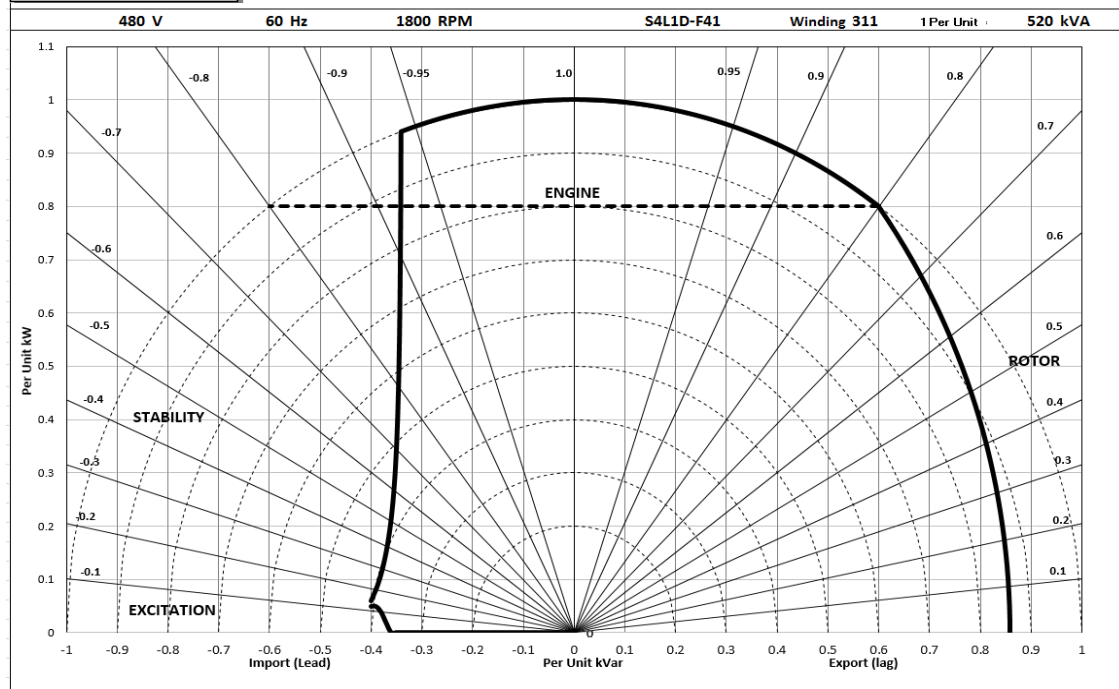

# STAMFORD®

## S4L1D-F41 Wdg.311

### RATINGS AT 0.8 POWER FACTOR

Class - Temp Rise		Standby - 163/27°C				Standby - 150/40°C				Cont. H - 125/40°C				Cont. F - 105/40°C			
<b>50 Hz</b>	Series Star (V)	380	400	415	440	380	400	415	440	380	400	415	440	380	400	415	440
	kVA	425	465	455	440	415	445	445	430	400	415	415	400	370	380	380	370
	kW	340	372	364	352	332	356	356	344	320	332	332	320	296	304	304	296
	Efficiency (%)	92.8	92.6	92.9	93.4	92.9	92.9	93.1	93.5	93.1	93.2	93.4	93.8	93.5	93.6	93.8	94.0
	kW Input	366	402	392	377	357	383	383	368	344	356	355	341	317	325	324	315

<b>60 Hz</b>	Series Star (V)	416	440	460	480	416	440	460	480	416	440	460	480	416	440	460	480
	kVA	500	550	550	575	485	535	535	555	455	500	500	520	420	465	465	480
	kW	400	440	440	460	388	428	428	444	364	400	400	416	336	372	372	384
	Efficiency (%)	92.9	92.7	93.0	93.0	93.0	92.9	93.2	93.2	93.4	93.2	93.5	93.5	93.7	93.6	93.8	93.8
	kW Input	431	475	473	495	417	461	459	476	390	429	428	445	359	398	397	409

#### De-Rates

All values tabulated above are subject to the following reductions:

- 5% when air inlet filters are fitted
- 3% for every 500 meters by which the operating altitude exceeds 1000 meters above mean sea level
- 3% for every 5°C by which the operational ambient temperature exceeds 40°C
- For any other operating conditions impacting the cooling circuit please refer to applications

Note: Requirement for operating in an ambient exceeding 60°C and altitude exceeding 4000 meters must be referred to applications.

#### Dimensional and Torsional Drawing

For dimensional and torsional information please refer to the alternator General Arrangement and rotor drawings available on our website (<http://stamford-avk.com/>)

**Note:** Continuous development of our products means that the information contained in our data sheets can change without notice, and specifications should always be confirmed with Cummins Generator Technologies prior to purchase.



Follow us @stamfordavk



Cummins Generator Technologies



View our videos at [youtube.com/stamfordavk](https://youtube.com/stamfordavk)

**[news.stamford-avk.com](https://news.stamford-avk.com)**

**For Applications Support:**  
**[applications@cummins.com](mailto:applications@cummins.com)**

**For Customer Service:**  
**[service-engineers@stamford-avk.com](mailto:service-engineers@stamford-avk.com)**

**For General Enquiries:**  
**[info@cumminsgeneratortechnologies.com](mailto:info@cumminsgeneratortechnologies.com)**

Copyright 2016. Cummins Generator Technologies Ltd. All rights reserved.  
Cummins and the Cummins logo are registered trade marks of Cummins Inc.  
STAMFORD is a registered trade mark of Cummins Generator Technologies Ltd.



# STAMFORD®

HCI434F/444F - Winding 17

Technical <sup>VA</sup>Data Sheet

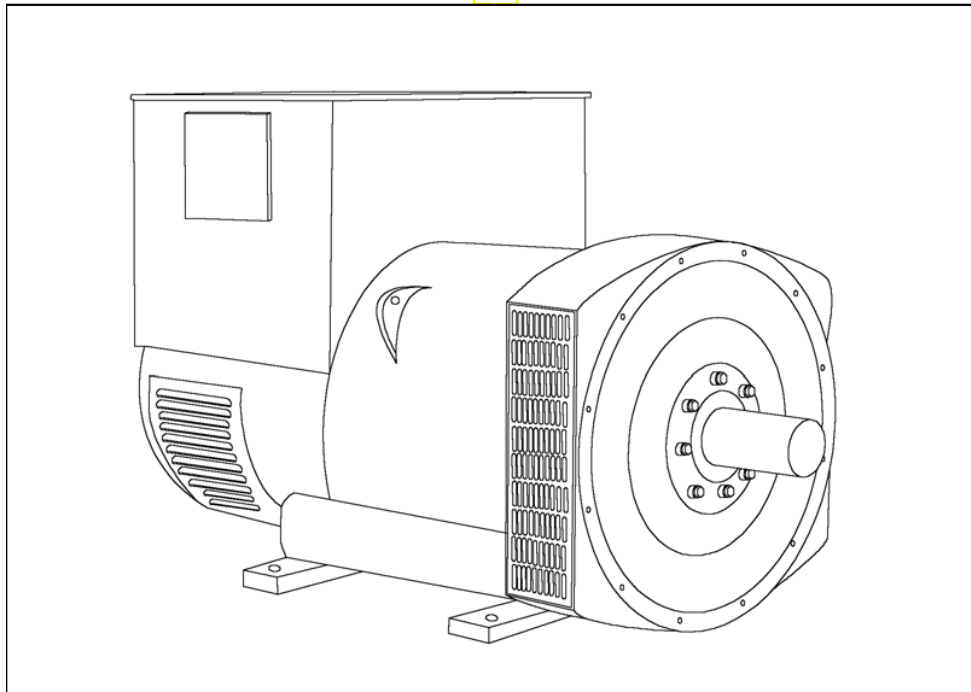

# HCI434F/444F

## SPECIFICATIONS & OPTIONS

**STAMFORD**

### STANDARDS

Stamford industrial generators meet the requirements of BS EN 60034 and the relevant section of other international standards such as BS5000, VDE 0530, NEMA MG1-32, IEC34, CSA C22.2-100, AS1359. Other standards and certifications can be considered on request.

### VOLTAGE REGULATORS

#### AS440 AVR - STANDARD

With this self-excited system the main stator provides power via the Automatic Voltage Regulator (AVR) to the exciter stator. The high efficiency semi-conductors of the AVR ensure positive build-up from initial low levels of residual voltage.

The exciter rotor output is fed to the main rotor through a three-phase full-wave bridge rectifier. The rectifier is protected by a surge suppressor against surges caused, for example, by short circuit or out-of-phase paralleling.

The AS440 will support a range of electronic accessories, including a 'droop' Current Transformer (CT) to permit parallel operation with other ac generators.

#### MX341 AVR

This sophisticated AVR is incorporated into the Stamford Permanent Magnet Generator (PMG) control system.

The PMG provides power via the AVR to the main exciter, giving a source of constant excitation power independent of generator output. The main exciter output is then fed to the main rotor, through a full wave bridge, protected by a surge suppressor. The AVR has in-built protection against sustained over-excitation, caused by internal or external faults. This de-excites the machine after a minimum of 5 seconds.

An engine relief load acceptance feature can enable full load to be applied to the generator in a single step.

If three-phase sensing is required with the PMG system the MX321 AVR must be used.

We recommend three-phase sensing for applications with greatly unbalanced or highly non-linear loads.

#### MX321 AVR

The most sophisticated of all our AVRs combines all the features of the MX341 with, additionally, three-phase rms sensing, for improved regulation and performance.

Over voltage protection is built-in and short circuit current level adjustments is an optional facility.

### WINDINGS & ELECTRICAL PERFORMANCE

All generator stators are wound to 2/3 pitch. This eliminates triplen (3rd, 9th, 15th ...) harmonics on the voltage waveform and is found to be the optimum design for trouble-free supply of non-linear loads. The 2/3 pitch design avoids excessive neutral currents sometimes seen with higher winding pitches, when in parallel with the mains. A fully connected damper winding reduces oscillations during paralleling. This winding, with the 2/3 pitch and carefully selected pole and tooth designs, ensures very low waveform distortion.

### TERMINALS & TERMINAL BOX

Standard generators are 3-phase reconnectable with 12 ends brought out to the terminals, which are mounted on a cover at the non-drive end of the generator. A sheet steel terminal box contains the AVR and provides ample space for the customers' wiring and gland arrangements. It has removable panels for easy access.

### SHAFT & KEYS

All generator rotors are dynamically balanced to better than BS6861:Part 1 Grade 2.5 for minimum vibration in operation. Two bearing generators are balanced with a half key.

### INSULATION/IMPREGNATION

The insulation system is class 'H'.

All wound components are impregnated with materials and processes designed specifically to provide the high build required for static windings and the high mechanical strength required for rotating components.

### QUALITY ASSURANCE

Generators are manufactured using production procedures having a quality assurance level to BS EN ISO 9001.

The stated voltage regulation may not be maintained in the presence of certain radio transmitted signals. Any change in performance will fall within the limits of Criteria 'B' of EN 61000-6-2:2001. At no time will the steady-state voltage regulation exceed 2%.

### DE RATES

All values tabulated on page 6 are subject to the following reductions

5% when air inlet filters are fitted.

3% for every 500 metres by which the operating altitude exceeds 1000 metres above mean sea level.

3% for every 5 C by which the operational ambient temperature exceeds 40 C.

Note: Requirement for operating in an ambient exceeding 60 C must be referred to the factory.

*NB Continuous development of our products entitles us to change specification details without notice, therefore they must not be regarded as binding.*

*Front cover drawing typical of product range.*

APPROVED DOCUMENT

# HCI434F/444F

**STAMFORD**

## WINDING 17

CONTROL SYSTEM	SEPARATELY EXCITED BY P.M.G.		
A.V.R.	MX321	MX341	
VOLTAGE REGULATION	± 0.5 %	± 1.0 %	With 4% ENGINE GOVERNING
SUSTAINED SHORT CIRCUIT	REFER TO SHORT CIRCUIT DECREMENT CURVES (page 5)		
CONTROL SYSTEM	SELF EXCITED		
A.V.R.	AS440		
VOLTAGE REGULATION	± 1.0 %		With 4% ENGINE GOVERNING
SUSTAINED SHORT CIRCUIT	WILL NOT SUSTAIN A SHORT CIRCUIT		
INSULATION SYSTEM	CLASS H		
PROTECTION	IP23		
RATED POWER FACTOR	0.8		
STATOR WINDING	DOUBLE LAYER LAP		
WINDING PITCH	TWO THIRDS		
WINDING LEADS	12		
STATOR WDG. RESISTANCE	0.011 Ohms PER PHASE AT 22°C SERIES STAR CONNECTED		
ROTOR WDG. RESISTANCE	1.37 Ohms at 22°C		
EXCITER STATOR RESISTANCE	18 Ohms at 22°C		
EXCITER ROTOR RESISTANCE	0.068 Ohms PER PHASE AT 22°C		
R.F.I. SUPPRESSION	BS EN 61000-6-2 & BS EN 61000-6-4, VDE 0875G, VDE 0875N. refer to factory for others		
WAVEFORM DISTORTION	NO LOAD < 1.5% NON-DISTORTING BALANCED LINEAR LOAD < 5.0%		
MAXIMUM OVERSPEED	2250 Rev/Min		
BEARING DRIVE END	BALL. 6317 (ISO)		
BEARING NON-DRIVE END	BALL. 6314 (ISO)		
	1 BEARING		2 BEARING
WEIGHT COMP. GENERATOR	1160 kg		1160 kg
WEIGHT WOUND STATOR	535 kg		535 kg
WEIGHT WOUND ROTOR	463 kg		440 kg
WR <sup>2</sup> INERTIA	5.4292 kgm <sup>2</sup>		5.2304 kgm <sup>2</sup>
SHIPPING WEIGHTS in a crate	1230 kg		1230 kg
PACKING CRATE SIZE	155 x 87 x 107 (cm)		155 x 87 x 107 (cm)
TELEPHONE INTERFERENCE	THF<2%		TIF<50
COOLING AIR	0.99 m <sup>3</sup> /sec 2100 cfm		
VOLTAGE SERIES STAR	600V		
VOLTAGE PARALLEL STAR	300V		
VOLTAGE SERIES DELTA	346V		
kVA BASE RATING FOR REACTANCE VALUES	500		
X <sub>d</sub> DIR. AXIS SYNCHRONOUS	2.73		
X' <sub>d</sub> DIR. AXIS TRANSIENT	0.19		
X'' <sub>d</sub> DIR. AXIS SUBTRANSIENT	0.13		
X <sub>q</sub> QUAD. AXIS REACTANCE	2.40		
X'' <sub>q</sub> QUAD. AXIS SUBTRANSIENT	0.36		
X <sub>L</sub> LEAKAGE REACTANCE	0.06		
X <sub>2</sub> NEGATIVE SEQUENCE	0.24		
X <sub>0</sub> ZERO SEQUENCE	0.08		
REACTANCES ARE SATURATED		VALUES ARE PER UNIT AT RATING AND VOLTAGE INDICATED	
T' <sub>d</sub> TRANSIENT TIME CONST.	0.08s		
T'' <sub>d</sub> SUB-TRANSTIME CONST.	0.019s		
T' <sub>do</sub> O.C. FIELD TIME CONST.	1.7s		
T <sub>a</sub> ARMATURE TIME CONST.	0.018s		
SHORT CIRCUIT RATIO	1/X <sub>d</sub>		

# HCI434F/444F

**STAMFORD**

Winding 17

**SX**

## Locked Rotor Motor Starting Curves

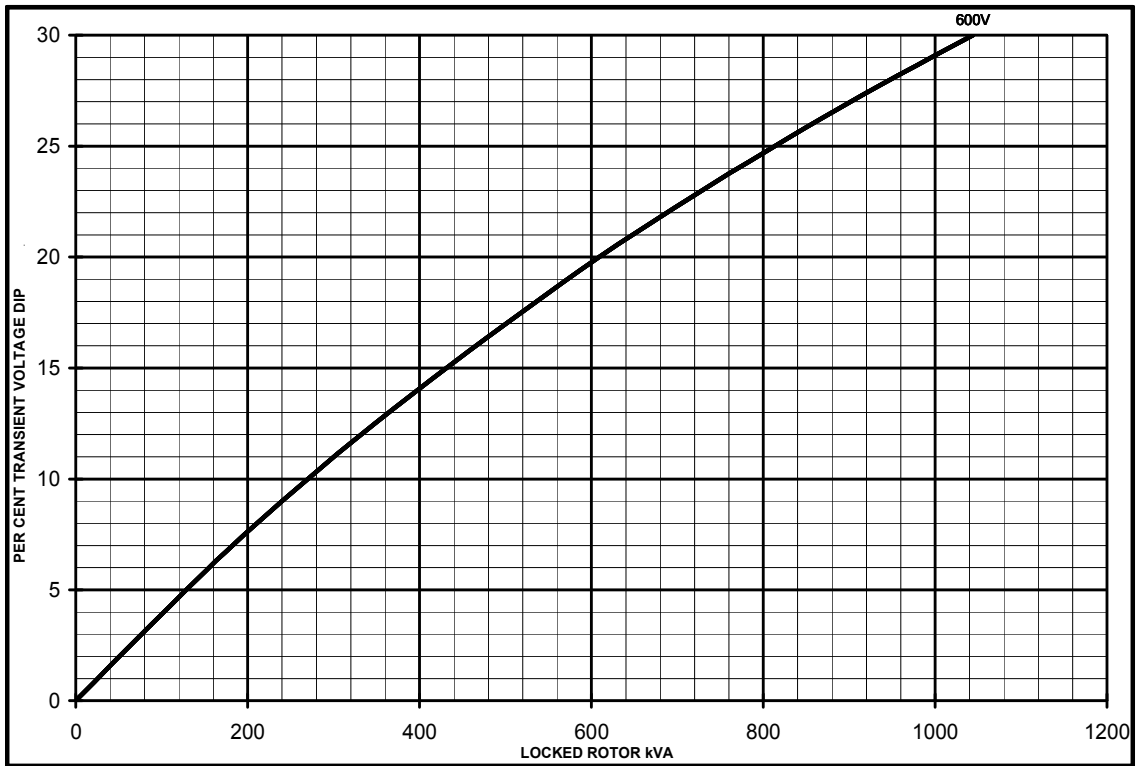

**MX**

OCU

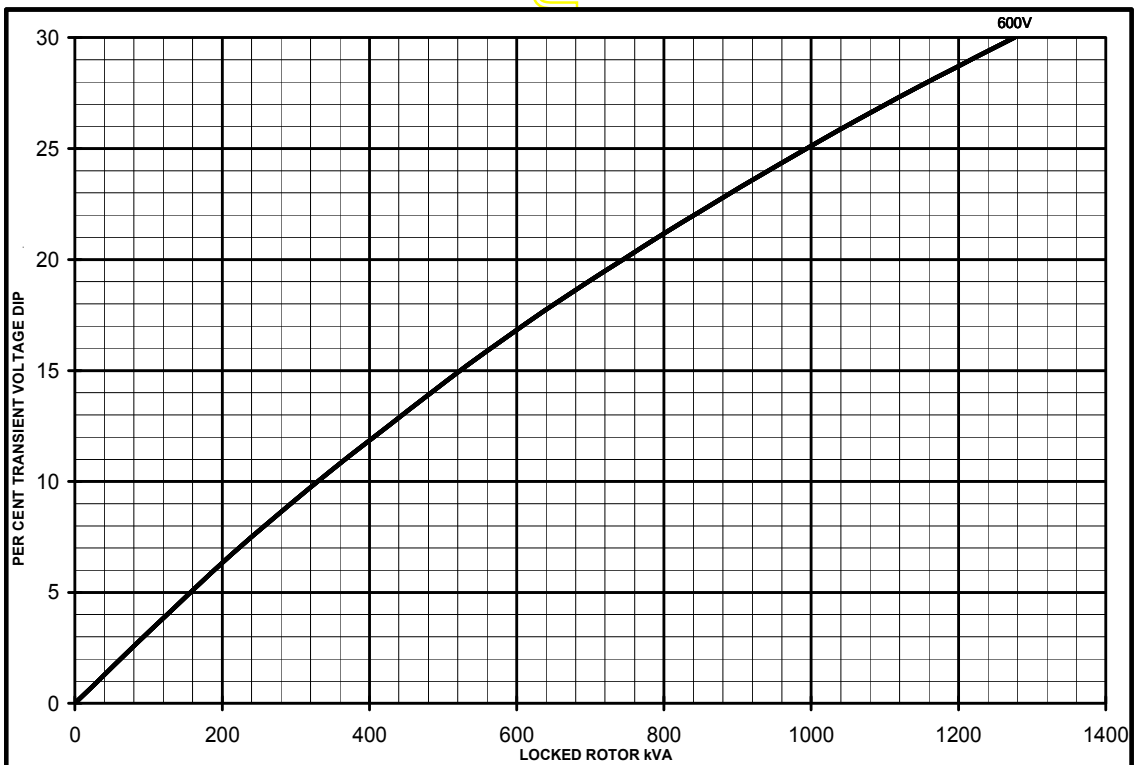

**HCI434F/444F**  
Winding 17

**STAMFORD**

**THREE PHASE EFFICIENCY CURVES**

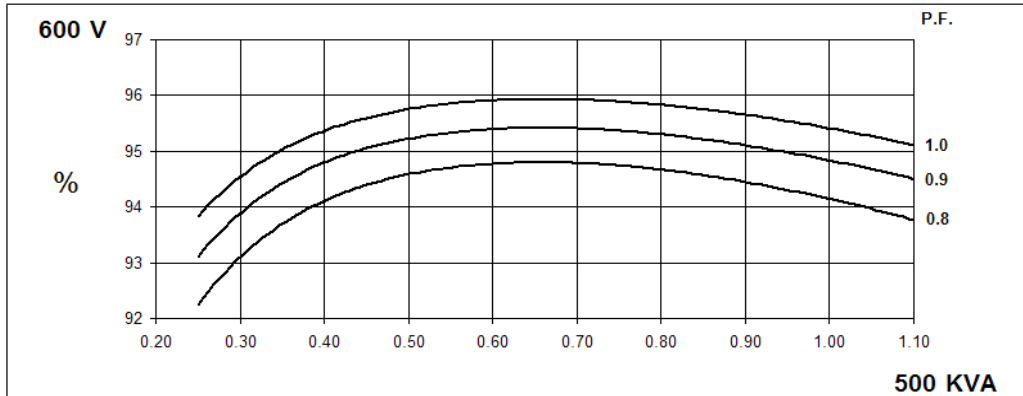

**Three-phase Short Circuit Decrement Curve. No-load Excitation at Rated Speed Based on star (wye) connection.**

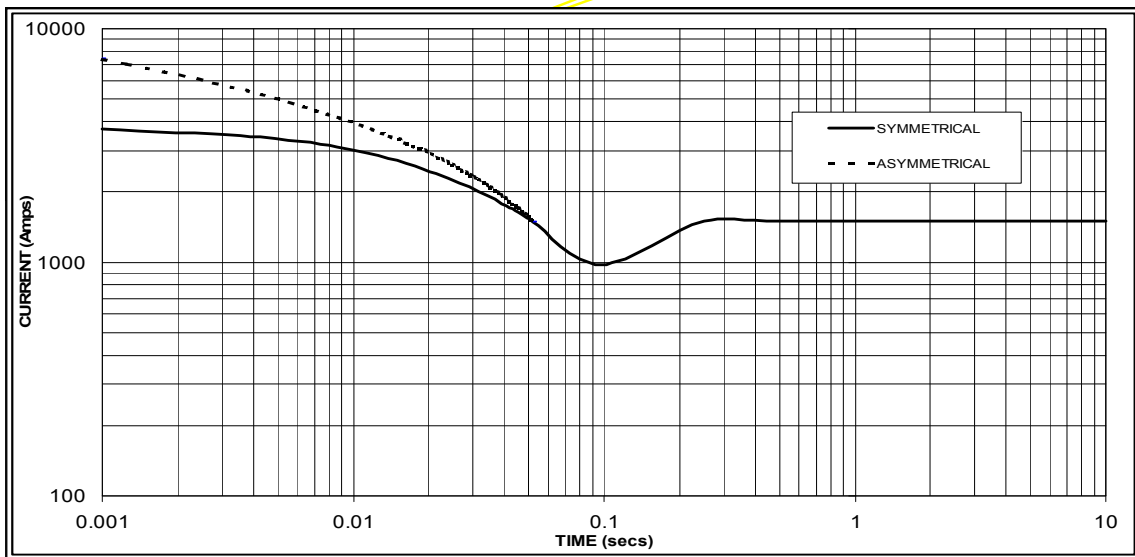

Sustained Short Circuit = 1500 Amps

**Note**

The following multiplication factor should be used to convert the values from curve for the various types of short circuit :

	3-phase	2-phase L-L	1-phase L-N
Instantaneous	x 1.00	x 0.87	x 1.30
Minimum	x 1.00	x 1.80	x 3.20
Sustained	x 1.00	x 1.50	x 2.50
Max. sustained duration	10 sec.	5 sec.	2 sec.

All other times are unchanged



# HCI434F/444F

**STAMFORD**

Winding 17 / 0.8 Power Factor

**60Hz**

## RATINGS

Class - Temp Rise	Cont. F - 105/40°C	Cont. H - 125/40°C	Standby - 150/40°C	Standby - 163/27°C
Series Star (V)	600	600	600	600
Parallel Star (V)	300	300	300	300
Series Delta (V)	346	346	346	346
kVA	465	500	535	550
kW	372	400	428	440
Efficiency (%)	94.4	94.1	93.9	93.8
kW Input	394	425	456	469

APPROXIMATE

## DIMENSIONS

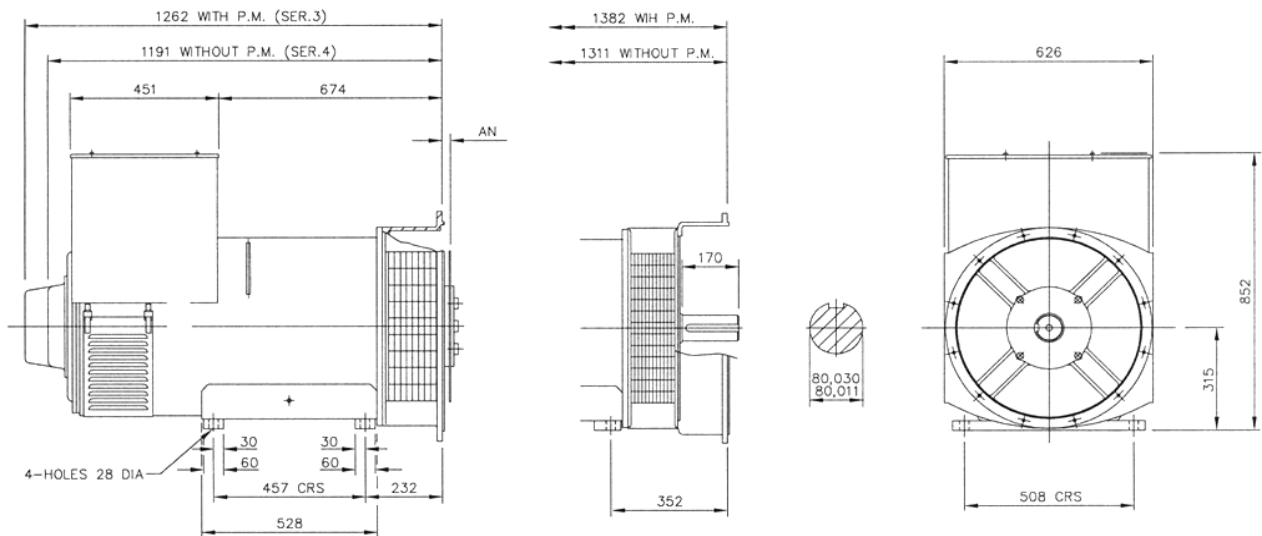

COUPLING DISC	AN
SAE 11,5	39,68
SAE 14	25,4
SAE 18	15,87

APPROVED DOCUMENT

**STAMFORD**

Head Office Address:  
Barnack Road, Stamford  
Lincolnshire, PE9 2NB  
United Kingdom  
Tel: +44 (0) 1780 484000  
Fax: +44 (0) 1780 484100

[www.cumminsgeneratortechnologies.com](http://www.cumminsgeneratortechnologies.com)

Copyright 2010, Cummins Generator Technologies Ltd, All Rights Reserved  
Stamford and AvK are registered trade marks of Cummins Generator Technologies Ltd  
Cummins and the Cummins logo are registered trade marks of Cummins Inc.

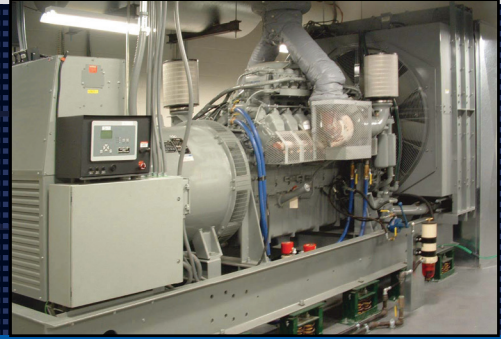

A highly advanced integrated genset control system, this device provides genset control, transfer switch control, metering, protection, and programmable logic in a simple, easy-to-use, reliable, rugged, and cost effective package.

**FEATURES**

- Generator metering (includes three-phase mains)
- Engine and generator protection: 27, 32R, 40Q, 59, 810/U
- Optional enhanced generator protection: 47, 51, 78, and 81ROCOF
- Load sharing and generator sequencing (via LSM-200 Load Share Module)
- Var sharing over Ethernet (via LSM-200)
- BESTCOMSP<sup>Plus</sup>® Software
  - Programming and setup
  - Intuitive and powerful
  - Remote control and monitoring
  - Programmable logic
  - USB communications
- Automatic transfer switch control
- Automatic synchronizer (optional)
- Exercise timer
- SAE J1939 engine ECU communications
- Automatic generator configuration detection
- Expandable functionality via add-on modules
  - [LSM-200 Load Share Module](#)
  - [CEM-200 Contact Expansion Module](#)
  - [AEM-200 Analog Expansion Module](#)
- Multilingual capability
- Remote communications to Basler's RDP-110 (remote display panel)
- Sixteen programmable contact inputs
- Up to 15 contact outputs: 3 contacts rated for 30 Adc and up to 12 programmable contacts rated for 2 Adc

**BENEFITS**

- Provides integrated engine-genset control, protection, and metering in a single package.
- The Offline Simulator, provided in BESTlogic™ Plus, helps test and troubleshoot logic without the need for expensive hardware.
- Flexible programmable logic and programmable I/O make it easy to expand the DGC-200's inputs and outputs with the CEM-200 (Contact Expansion Module) and the AEM-200 (Analog Expansion Module). This saves time and money by eliminating unnecessary external PLCs and control relaying.

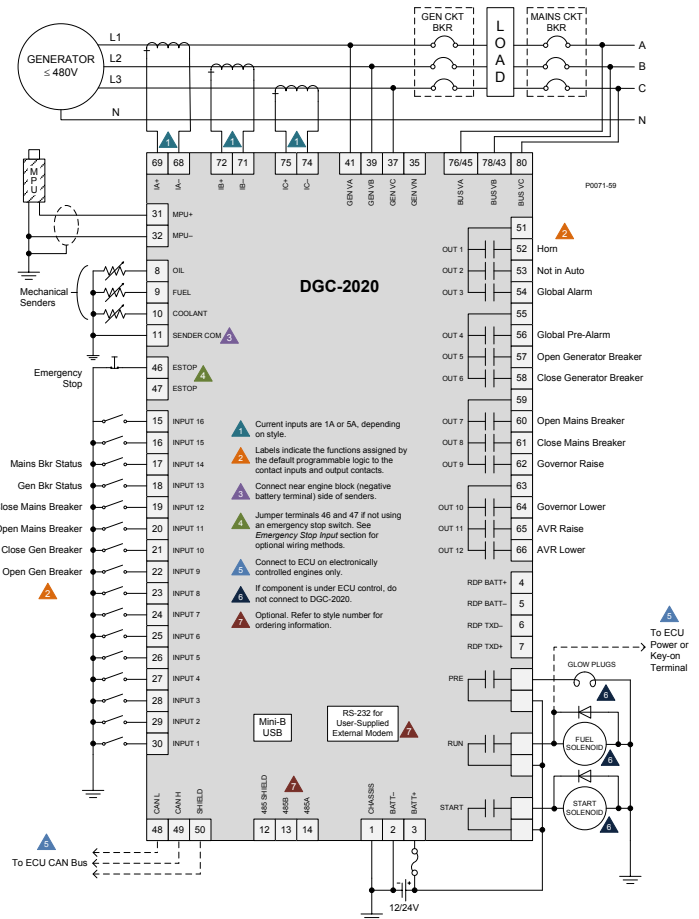

Figure 1 - DGC-200 Connection Diagram for a Typical Application

Visit [www.basler.com](http://www.basler.com)  
FOR ADDITIONAL INFORMATION.

SPECIFICATIONS

Power Supply

Nominal: 12 or 24 Vdc  
 Range: 6 to 32 Vdc  
 Battery Ride Through: Starting at 10 Vdc, withstands cranking ride-through down to 0 V for 50 ms

Power Consumption

Sleep Mode: 5 W  
 Normal Operational Mode: 7.9 W  
 Maximum: 14.2 W

Current Sensing

1 A Sensing: 0.02 to 1.0 Aac, continuous  
 2 Aac for 1 second  
 5 A Sensing: 0.1 to 5.0 Aac, continuous  
 10 Aac for 1 second  
 Burden: 1 VA

Voltage Sensing

Range: 12 to 576 Vrms L-L  
 Frequency Range: 10 to 72 Hz for 50/60 Hz style,  
 10 to 480 Hz for 400 Hz style  
 Burden: 1 VA  
 One-second Rating: 720 Vrms

Contact Sensing

Contact Inputs (16): Accepts normally open (N.O.), Dry Contacts, programmable  
 Emergency Stop: Normally closed (N.C.), Dry Contact

Engine Speed Sensing

Magnetic Pickup:  
 Voltage Range: 6 to 70 Vpp  
 Frequency Range: 32 to 10,000 Hz  
 Generator Frequency:  
 Generator Voltage Range: 12 to 576 Vrms  
 Via ECU over J1939

Resistive Senders

Fuel Level Sender: 0 to 250 Ω nominal  
 Coolant Temp Sender: 10 to 2,750 Ω nominal  
 Oil Pressure Sender: 0 to 250 Ω nominal

Output Contacts

Fuel Solenoid, Engine Crank,  
 Pre-Start Relays Rating: 30 Adc at 28 Vdc-make, break, and carry  
 Programmable Relays: Up to 12  
 Rating: 2 Adc at 28 Vdc-make, break, and carry

Protection

Generator: 27, 32R, 40Q, 59, 810/U (standard)  
 47, 51, 78, 81 ROCOF (optional)  
 Engine: Oil pressure, coolant temperature, overcrank, ECU-specific elements, and diagnostic reporting.

Agency Approvals

CSA certified, NFPA compliant, CE compliant,  
 UL recognized (Hazardous Location certification available upon request), EAC certified

Communication

USB Port: USB 2.0, Mini-B jack  
 RS-485 (optional): 9600 baud, 8 data bits, no parity  
 RDP-110 (optional): 4,000 ft (1,219 m) max wire length, 20 AWG (0.52 mm<sup>2</sup>) min wire size  
 Modem (optional): DB-9 connector (male)  
 CAN bus: 250 kb/s communication rate, 1.5 to 3 Vdc differential bus

Environmental

Operating Temp: -40°C to 70°C (-40°F to 158°F)  
 Storage Temp: -40°C to 85°C (-40°F to 185°F)  
 Humidity: IEC 68-2-38  
 Salt Fog: ASTM B 17-73, IEC 68-2-11  
 Ingress Protection: IEC IP54 for front panel  
 Shock: 15 G in three perpendicular planes  
 Vibration:  
 5 to 29 Hz: 1.5 G peak  
 29 to 52 Hz: 0.036" (0.914 mm) double amplitude  
 52 to 500 Hz: 5 G peak

Physical

Weight: 4.4 lb (2 kg)  
 Dimensions (WxHxD): 11.77 x 8.27 x 2.69 inches (299 x 210 x 69 mm)

For complete specifications, download the instruction manual at [www.basler.com](http://www.basler.com).

STYLE CHART

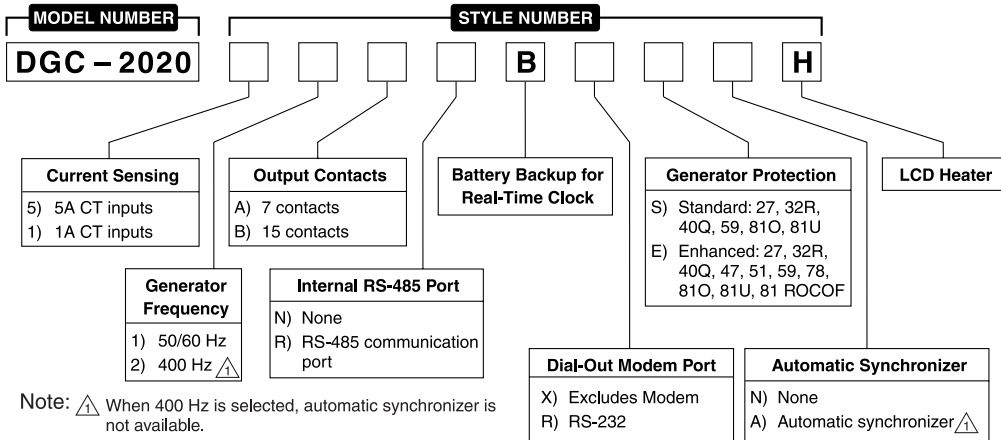

RELATED PRODUCTS

- [BE1-11g Generator Protection System](#)
  - A complete generator protection system.
- [DECS-250 Digital Excitation Control System](#)
  - Total control in a compact package provides precise voltage, var and power factor regulation, exceptional system response, and generator protection.

ACCESSORIES

- [AEM-2020 Analog Expansion Module](#)
  - Easily increases the functionality by seamlessly adding analog inputs and outputs.
- [CEM-2020, CEM-2020H Contact Expansion Module](#)
  - Each module adds 10 inputs and up to 24 outputs that are easily programmed through BESTCOMSPUs<sup>®</sup> for easy integration into the system.
- [LSM-2020 Load Share Module](#)
  - The simple-to-use LSM-2020 easily adds paralleling capabilities with little effort and expense.
- [RDP-110 Remote Display Panel](#)
  - Provides remote alarm and pre-alarm indication and annunciation of system status, easily meeting the annunciation requirements of NFPA-110 applications.



ISO 9001-2008  
 Highland, IL USA Wasselonne, France  
 Taylor, TX USA Suzhou, China  
 Basler Plastics, LLC



12570 State Route 143, Highland, Illinois 62249-1074 USA  
 Tel +1 618.654.2341 Fax +1 618.654.2351  
 email:info@basler.com www.basler.com

P.A.E. Les Pins, 67319 Wasselonne Cedex, FRANCE  
 Tel +33 3.88.87.1010 Fax +33 3.88.87.0808  
 e-mail: franceinfo@basler.com

No. 59 Heshun Road Loufeng District (N),  
 Suzhou Industrial Park, 215122, Suzhou, P.R.China  
 Tel +86(0)512.8227.2888 Fax +86(0)512.8227.2887  
 e-mail: chinainfo@basler.com

111 North Bridge Road #15-06 Peninsula Plaza  
 Singapore 179098  
 Tel +65 68.44.6445 Fax +65 68.44.8902  
 e-mail: singaporeinfo@basler.com

**Molded Case Circuit Breakers**  
**Power Defense™ UL Global Series**  
**Part Number: PDG33G0600B2NJNNNNNN**



Datasheet creation date: 02/12/2019

**PRODUCT VIEW** *(Use Mouse to Rotate and Zoom)*

Eaton's Power Defense™ molded case circuit breakers, a globally rated platform designed to help keep your power system safe with latest protection technology. Engineered for the future: IoT and Industry 4.0 features such as built-in communications, advanced energy metering, and algorithms that signal breaker maintenance; zone selective interlock technology that clears faults quickly and locally; ArcFlash reduction options that help protect your people, and not to mention Eaton's best-in-class support and service.

**Tech Data for Configured Product**

<b>Power Defense Catalog Number</b>	PDG33G0600B2NJNNNNNN
<b>Frame Size</b>	Frame 3
<b>Poles</b>	3 Pole
<b>Voltage</b>	480V AC
<b>Interruption or Breaking Capacity ( Icu/Ics)</b>	35kA
<b>Continuous Current Rating (In)</b>	600A
<b>Trip Unit Type</b>	PXR10
<b>Trip Unit Options 1</b>	LSI
<b>Trip Unit Options 2</b>	None
<b>Indicating Accessories</b>	None
<b>Indicating Accessories Terminal</b>	None
<b>Tripping Accessories</b>	None
<b>Tripping Accessory Terminal</b>	None
<b>Tripping Accessory Voltage</b>	None
<b>Line Type Description</b>	Option 1 - Standard Terminal
<b>Line Conductor Options</b>	(2) 2 - 500
<b>Line Terminal Type</b>	Aluminum
<b>Load Type Description</b>	Option 1 - Standard Terminal
<b>Load Conductor Options</b>	(2) 2 - 500
<b>Load Terminal Type</b>	Aluminum
<b>Special Options - Type of Modification</b>	None
<b>Details</b>	None
<b>Additional Description</b>	None

**Molded Case Circuit Breakers**  
**Power Defense™ UL Global Series**  
**Part Number: PDG33G0600B2NJNNNNN**

**Technical drawings**

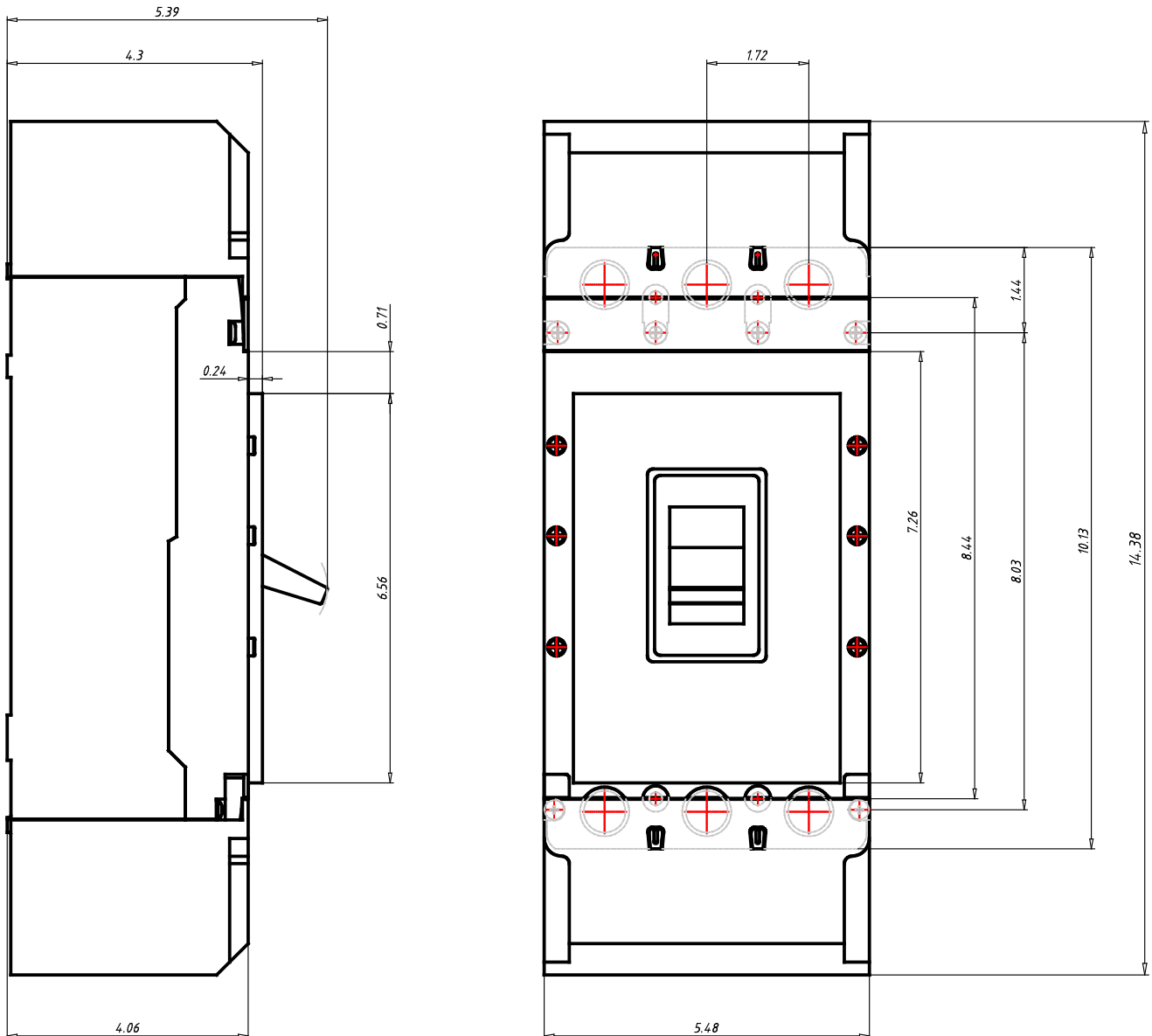

**Molded Case Circuit Breakers**  
**Power Defense™ UL Global Series**  
**Part Number: PDG33G0600B2NJNNNNNN**



Datasheet creation date: 02/12/2019

**General Technical Data**

Frame Rating (In)	600A
Reference Standard	UL489, CSA 22.2, IEC 60947-2 & GB
Number of poles	3
Neutral rating	-
Interruption Rating Designator	F / G / K / M / N / P
UL Interruption Rating to UL 489 (240Vac)	35 / 65 / 85 / 100 / 150 / 200kA
UL Interruption Rating to UL 489 (480Vac)	25 / 35 / 50 / 65(a) / 85 / 100kA
UL Interruption Rating to UL 489 (600Vac)	14 / 18 / 25 / 35 / 50 / 65kA
UL Interruption Rating to UL 489 (125/250Vdc)	
UL Current Limiting	N / N / N / N / Y / Y
Rated breaking capacity to IEC 60947-2 (220-240 Vac Icu)	35 / 55 / 85 / 100 / 150 / 200kA
Rated breaking capacity to IEC 60947-2 (220-240 Vac Ics)	35 / 55 / 85 / 100 / 100 / 150kA
Rated breaking capacity to IEC 60947-2 (380-415 Vac Icu)	25 / 36 / 50 / 70 / 70 / 100kA
Rated breaking capacity to IEC 60947-2 (380-415 Vac Ics)	25 / 36 / 50 / 53 / 70 / 70kA
Rated breaking capacity to IEC 60947-2 (440 Vac Icu)	25 / 30 / 35 / 50 / 70 / 100kA
Rated breaking capacity to IEC 60947-2 (440 Vac Ics)	20 / 22.5 / 35 / 40 / 50 / 50kA
Rated breaking capacity to IEC 60947-2 (525 Vac Icu)	18 / 20 / 25 / 30 / 35 / 40kA
Rated breaking capacity to IEC 60947-2 (525 Vac Ics)	5 / 7.5 / 10 / 15 / 25 / 25kA
Rated breaking capacity to IEC 60947-2 (690 Vac Icu)	- / 8 / 10 / 15 / 20 / 20kA
Rated breaking capacity to IEC 60947-2 (690 Vac Ics)	- / 4 / 5 / 7.5 / 10 / 10kA
Rated breaking capacity to IEC 60947-2 (125V DC Icu)	
Rated breaking capacity to IEC 60947-2 (250V DC 2P in series Ics)	10 / 10 / 10 / 22 / 22 / 22kA
Frequency	50/60Hz
Trip Unit Type	PXR10
Continuous Current Range	250 - 600A
100% UL489 Rated	Yes
Instantaneous/Short Circuit Range	2 - 10 In
Magnetic/Instantaneous Override	7200A
Dimensions H x W x D (inches)	10.125 x 5.47 x 4.297
Pole to pole distance inches	1,719
Approx Weight lbs	16
RoHS Compliance	Yes
UL File Number	E7819
Ambient Temp Calibration	
Derating at 50C	
Derating at 60C	
Derating at 70C	

1. 480Vac corresponds to 277Vac for 1P
2. 600Vac corresponds to 347Vac for 1P

**Molded Case Circuit Breakers**  
**Power Defense™ UL Global Series**  
**Part Number: PDG43G0800B2NJNNNNNN**



Datasheet creation date: 20/11/2019

**PRODUCT VIEW** *(Use Mouse to Rotate and Zoom)*

Eaton's Power Defense™ molded case circuit breakers, a globally rated platform designed to help keep your power system safe with latest protection technology. Engineered for the future: IoT and Industry 4.0 features such as built-in communications, advanced energy metering, and algorithms that signal breaker maintenance; zone selective interlock technology that clears faults quickly and locally; ArcFlash reduction options that help protect your people, and not to mention Eaton's best-in-class support and service.

**Tech Data for Configured Product**

<b>Power Defense Catalog Number</b>	PDG43G0800B2NJNNNNNN
<b>Frame Size</b>	Frame 4
<b>Poles</b>	3 Pole
<b>Voltage</b>	240V AC
<b>Interruption or Breaking Capacity ( Icu/Ics)</b>	55kA
<b>Continuous Current Rating (In)</b>	800A
<b>Trip Unit Type</b>	PXR10
<b>Trip Unit Options 1</b>	LSI
<b>Trip Unit Options 2</b>	None
<b>Indicating Accessories</b>	None
<b>Indicating Accessories Terminal</b>	None
<b>Tripping Accessories</b>	None
<b>Tripping Accessory Terminal</b>	None
<b>Tripping Accessory Voltage</b>	None
<b>Line Type Description</b>	Option 1 - Standard Terminal
<b>Line Conductor Options</b>	(3) 3/0 - 400
<b>Line Terminal Type</b>	Aluminum
<b>Load Type Description</b>	Option 1 - Standard Terminal
<b>Load Conductor Options</b>	(3) 3/0 - 400
<b>Load Terminal Type</b>	Aluminum
<b>Special Options - Type of Modification</b>	None
<b>Details</b>	None
<b>Additional Description</b>	None



**Molded Case Circuit Breakers**  
**Power Defense™ UL Global Series**  
**Part Number: PDG43G0800B2NJNNNNNN**

**Technical drawings**

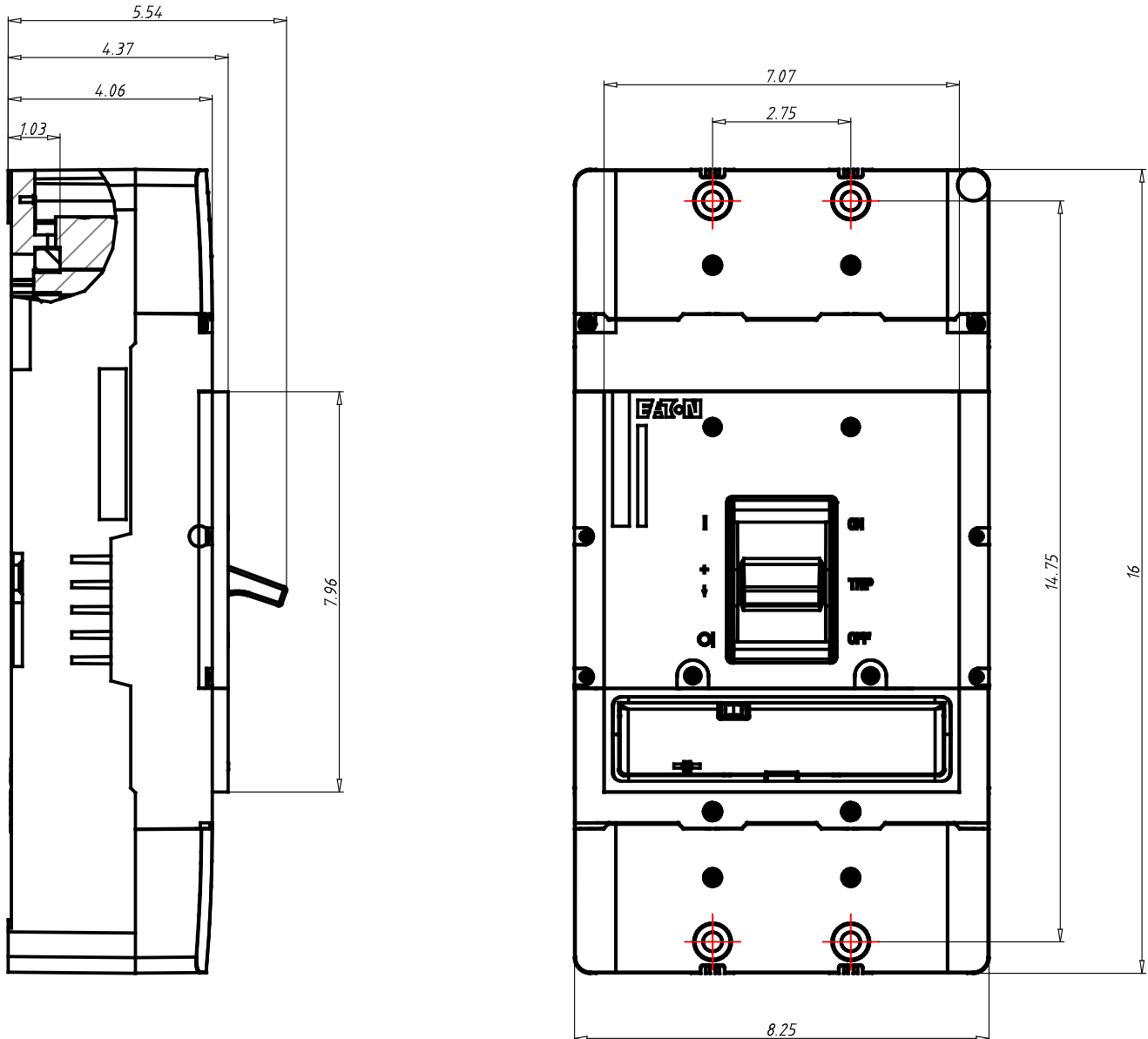

**Molded Case Circuit Breakers**  
**Power Defense™ UL Global Series**  
**Part Number: PDG43G0800B2NJNNNNNN**



Datasheet creation date: 20/11/2019

**General Technical Data**

Frame Rating (In)	800A
Reference Standard	UL489, CSA 22.2, IEC 60947-2 & GB
Number of poles	3
Neutral rating	-
Interruption Rating Designator	G / K / M
UL Interruption Rating to UL 489 (240Vac)	65 / 85 / 100kA
UL Interruption Rating to UL 489 (480Vac)	35 / 50 / 65(a)kA
UL Interruption Rating to UL 489 (600Vac)	18 / 25 / 35kA
UL Interruption Rating to UL 489 (125/250Vdc)	
UL Current Limiting	-
Rated breaking capacity to IEC 60947-2 (220-240 Vac Icu)	55 / 85 / 100 / 100kA
Rated breaking capacity to IEC 60947-2 (220-240 Vac Ics)	55 / 85 / 100 / 100kA
Rated breaking capacity to IEC 60947-2 (380-415 Vac Icu)	36 / 50 / 70 / 70kA
Rated breaking capacity to IEC 60947-2 (380-415 Vac Ics)	36 / 50 / 53 / 70kA
Rated breaking capacity to IEC 60947-2 (440 Vac Icu)	30 / 35 / 50 / 65kA
Rated breaking capacity to IEC 60947-2 (440 Vac Ics)	22.5 / 35 / 40 / 50kA
Rated breaking capacity to IEC 60947-2 (525 Vac Icu)	20 / 25 / 30 / 35kA
Rated breaking capacity to IEC 60947-2 (525 Vac Ics)	16.5 / 20 / 25 / 25kA
Rated breaking capacity to IEC 60947-2 (690 Vac Icu)	8 / 10 / 15 / 20kA
Rated breaking capacity to IEC 60947-2 (690 Vac Ics)	4 / 5 / 7.5 / 10kA
Rated breaking capacity to IEC 60947-2 (125V DC Icu)	
Rated breaking capacity to IEC 60947-2 (250V DC 2P in series Ics)	22 / 22 / 25kA
Frequency	50/60Hz
Trip Unit Type	PXR10
Continuous Current Range	320 - 800A
100% UL489 Rated	Yes
Instantaneous/Short Circuit Range	2 - 8 In
Magnetic/Instantaneous Override	6800A
Dimensions H x W x D (inches)	16 x 8.25 x 4.38
Pole to pole distance inches	2,75
Approx Weight lbs	29,98
RoHS Compliance	Yes
UL File Number	E7819
Ambient Temp Calibration	
Derating at 50C	
Derating at 60C	
Derating at 70C	

1. 480Vac corresponds to 277Vac for 1P
2. 600Vac corresponds to 347Vac for 1P

**Molded Case Circuit Breakers**  
**Power Defense™ UL Global Series**  
**Part Number: PDG53K1200E3RNNNNNNN**



Datasheet creation date: 19/08/2019

**PRODUCT VIEW** *(Use Mouse to Rotate and Zoom)*

Eaton's Power Defense™ molded case circuit breakers, a globally rated platform designed to help keep your power system safe with latest protection technology. Engineered for the future: IoT and Industry 4.0 features such as built-in communications, advanced energy metering, and algorithms that signal breaker maintenance; zone selective interlock technology that clears faults quickly and locally; ArcFlash reduction options that help protect your people, and not to mention Eaton's best-in-class support and service.

**Tech Data for Configured Product**

<b>Power Defense Catalog Number</b>	PDG53K1200E3RNNNNNNN
<b>Frame Size</b>	Frame 5
<b>Poles</b>	3 Pole
<b>Voltage</b>	480V AC
<b>Interruption or Breaking Capacity ( Icu/Ics)</b>	50kA
<b>Continuous Current Rating (In)</b>	1200A
<b>Trip Unit Type</b>	PXR20
<b>Trip Unit Options 1</b>	LSIG
<b>Trip Unit Options 2</b>	Relays
<b>Indicating Accessories</b>	None
<b>Indicating Accessories Terminal</b>	None
<b>Tripping Accessories</b>	None
<b>Tripping Accessory Terminal</b>	None
<b>Tripping Accessory Voltage</b>	None
<b>Line Type Description</b>	None
<b>Line Conductor Options</b>	N/A
<b>Line Terminal Type</b>	N/A
<b>Load Type Description</b>	None
<b>Load Conductor Options</b>	N/A
<b>Load Terminal Type</b>	N/A
<b>Special Options - Type of Modification</b>	None
<b>Details</b>	None
<b>Additional Description</b>	None

**Molded Case Circuit Breakers**  
**Power Defense™ UL Global Series**  
**Part Number: PDG53K1200E3RNNNNNN**

**Technical drawings**

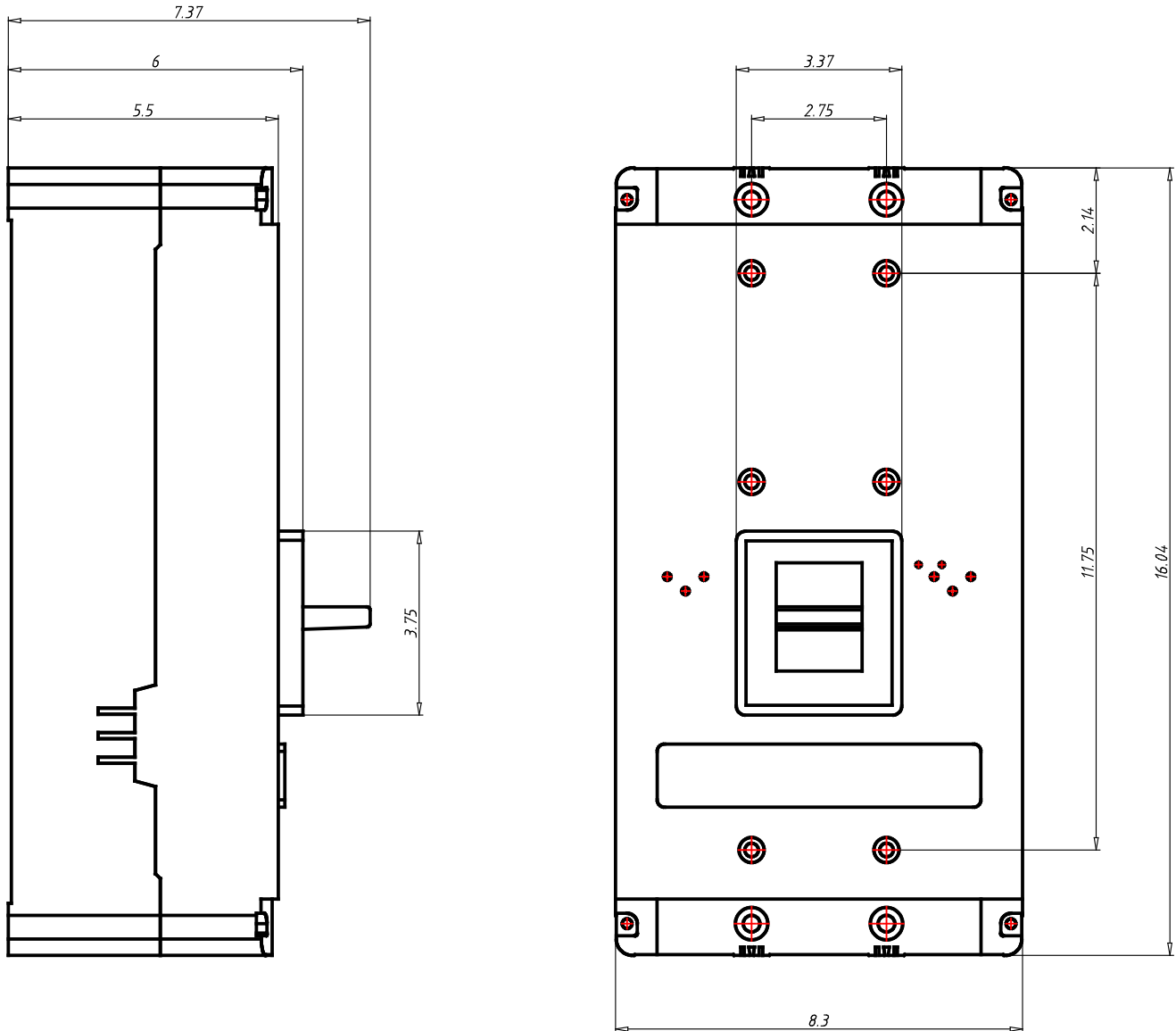

**Molded Case Circuit Breakers**  
**Power Defense™ UL Global Series**  
**Part Number: PDG53K1200E3RNNNNNNN**



Datasheet creation date: 19/08/2019

**General Technical Data**

Frame Rating (In)	1200A
Reference Standard	UL489, CSA 22.2, IEC 60947-2 & GB
Number of poles	3
Neutral rating	-
Interruption Rating Designator	K / M / N / P / T
UL Interruption Rating to UL 489 (240Vac)	85 / 100 / 150 / 200 / 200kA
UL Interruption Rating to UL 489 (480Vac)	50 / 65 / 85 / 100 / 150kA
UL Interruption Rating to UL 489 (600Vac)	25 / 35 / 50 / 65 / 65kA
UL Interruption Rating to UL 489 (125/250Vdc)	
UL Current Limiting	-
Rated breaking capacity to IEC 60947-2 (220-240 Vac Icu)	85 / 100 / 150 / 200kA
Rated breaking capacity to IEC 60947-2 (220-240 Vac Ics)	85 / 100 / 100 / 150kA
Rated breaking capacity to IEC 60947-2 (380-415 Vac Icu)	50 / 70 / 70 / 100kA
Rated breaking capacity to IEC 60947-2 (380-415 Vac Ics)	50 / 50 / 50 / 50kA
Rated breaking capacity to IEC 60947-2 (440 Vac Icu)	35 / 50 / 70 / 100kA
Rated breaking capacity to IEC 60947-2 (440 Vac Ics)	35 / 40 / 50 / 50kA
Rated breaking capacity to IEC 60947-2 (525 Vac Icu)	25 / 30 / 35 / 40kA
Rated breaking capacity to IEC 60947-2 (525 Vac Ics)	20 / 25 / 25 / 25kA
Rated breaking capacity to IEC 60947-2 (690 Vac Icu)	10 / 15 / 20 / 35kA
Rated breaking capacity to IEC 60947-2 (690 Vac Ics)	5 / 7.5 / 10 / 18kA
Rated breaking capacity to IEC 60947-2 (125V DC Icu)	
Rated breaking capacity to IEC 60947-2 (250V DC 2P in series Ics)	25
Frequency	50/60Hz
Trip Unit Type	PXR20
Continuous Current Range	500 - 1200A
100% UL489 Rated	Yes
Instantaneous/Short Circuit Range	2 - 10 In
Magnetic/Instantaneous Override	14400A
Dimensions H x W x D (inches)	16 x 8.25 x 5.5
Pole to pole distance inches	2,75
Approx Weight lbs	45
RoHS Compliance	Yes
UL File Number	E7819
Ambient Temp Calibration	
Derating at 50C	
Derating at 60C	
Derating at 70C	

1. 480Vac corresponds to 277Vac for 1P
2. 600Vac corresponds to 347Vac for 1P

**Molded Case Circuit Breakers**  
**Power Defense™ UL Global Series**  
**Part Number: PDG63M1600E3RNNNNNNN**



Datasheet creation date: 26/08/2019

**PRODUCT VIEW** *(Use Mouse to Rotate and Zoom)*

Eaton's Power Defense™ molded case circuit breakers, a globally rated platform designed to help keep your power system safe with latest protection technology. Engineered for the future: IoT and Industry 4.0 features such as built-in communications, advanced energy metering, and algorithms that signal breaker maintenance; zone selective interlock technology that clears faults quickly and locally; ArcFlash reduction options that help protect your people, and not to mention Eaton's best-in-class support and service.

**Tech Data for Configured Product**

Power Defense Catalog Number	PDG63M1600E3RNNNNNNN
Frame Size	Frame 6
Poles	3 Pole
Voltage	480V AC
Interruption or Breaking Capacity ( Icu/Ics)	65kA
Continuous Current Rating (In)	1600A
Trip Unit Type	PXR20
Trip Unit Options 1	LSIG
Trip Unit Options 2	Relays
Indicating Accessories	None
Indicating Accessories Terminal	None
Tripping Accessories	None
Tripping Accessory Terminal	None
Tripping Accessory Voltage	None
Line Type Description	None
Line Conductor Options	N/A
Line Terminal Type	N/A
Load Type Description	None
Load Conductor Options	N/A
Load Terminal Type	N/A
Special Options - Type of Modification	None
Details	None
Additional Description	None

**Molded Case Circuit Breakers**  
**Power Defense™ UL Global Series**  
**Part Number: PDG63M1600E3RNNNNNNN**

**Technical drawings**

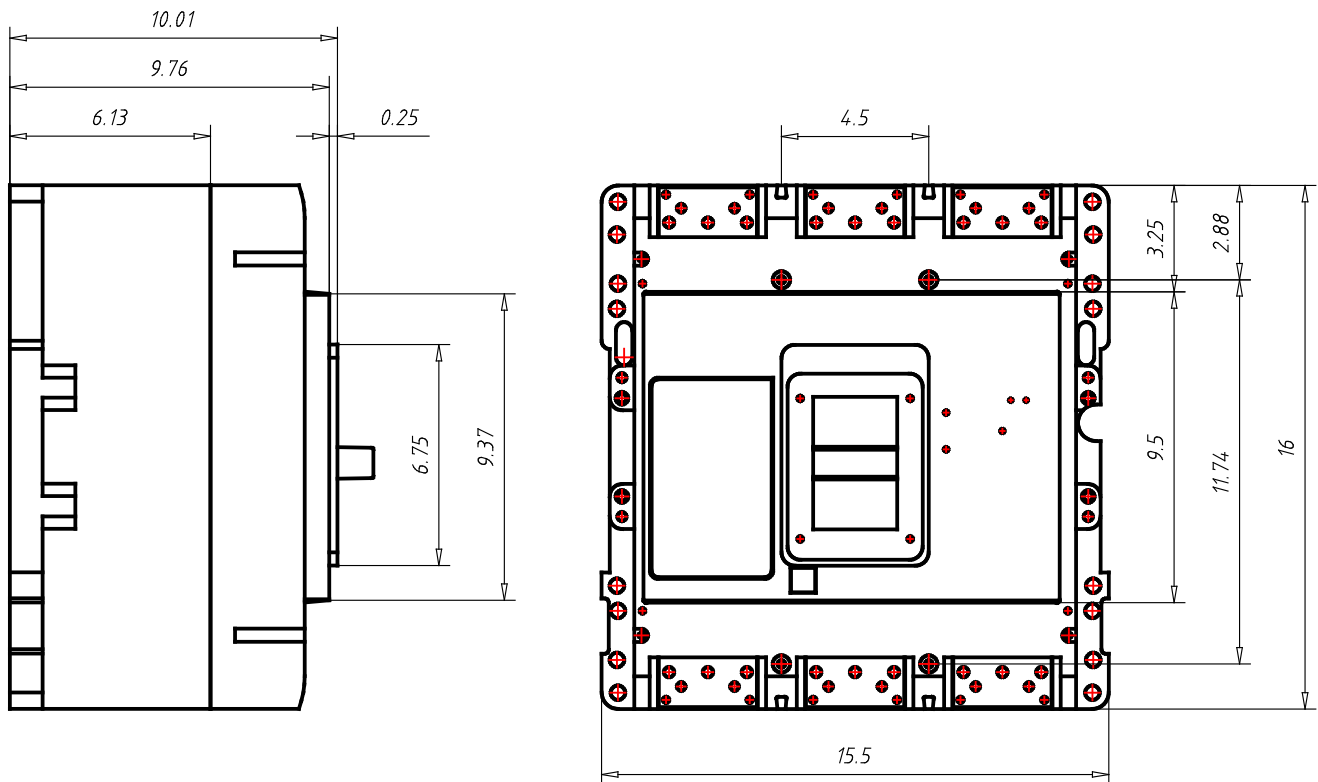

**Molded Case Circuit Breakers**  
**Power Defense™ UL Global Series**  
**Part Number: PDG63M1600E3RNNNNNNN**

**General Technical Data**

Frame Rating (In)	1600A
Reference Standard	UL489, CSA 22.2, IEC 60947-2 & GB
Number of poles	3
Neutral rating	-
Interruption Rating Designator	M / N / P
UL Interruption Rating to UL 489 (240Vac)	125 / 150 / 200kA
UL Interruption Rating to UL 489 (480Vac)	65 / 85 / 100kA
UL Interruption Rating to UL 489 (600Vac)	35 / 50 / 65kA
UL Interruption Rating to UL 489 (125/250Vdc)	
UL Current Limiting	-
Rated breaking capacity to IEC 60947-2 (220-240 Vac Icu)	135 / 150 / 200kA
Rated breaking capacity to IEC 60947-2 (220-240 Vac Ics)	100 / 100 / 100kA
Rated breaking capacity to IEC 60947-2 (380-415 Vac Icu)	70 / 70 / 100kA
Rated breaking capacity to IEC 60947-2 (380-415 Vac Ics)	50 / 50 / 50kA
Rated breaking capacity to IEC 60947-2 (440 Vac Icu)	50 / 70 / 100kA
Rated breaking capacity to IEC 60947-2 (440 Vac Ics)	40 / 50 / 50kA
Rated breaking capacity to IEC 60947-2 (525 Vac Icu)	30 / 35 / 40kA
Rated breaking capacity to IEC 60947-2 (525 Vac Ics)	25 / 25 / 25kA
Rated breaking capacity to IEC 60947-2 (690 Vac Icu)	15 / 20 / 35kA
Rated breaking capacity to IEC 60947-2 (690 Vac Ics)	7.5 / 13 / 18kA
Rated breaking capacity to IEC 60947-2 (125V DC Icu)	
Rated breaking capacity to IEC 60947-2 (250V DC 2P in series Ics)	25
Frequency	50/60Hz
Trip Unit Type	PXR20
Continuous Current Range	Fixed
100% UL489 Rated	Yes
Instantaneous/Short Circuit Range	Adjustable
Magnetic/Instantaneous Override	17500A
Dimensions H x W x D (inches)	16 x 15.5 x 9.75
Pole to pole distance inches	4,5
Approx Weight lbs	135
RoHS Compliance	Yes
UL File Number	E7819
Ambient Temp Calibration	
Derating at 50C	
Derating at 60C	
Derating at 70C	

1. 480Vac corresponds to 277Vac for 1P
2. 600Vac corresponds to 347Vac for 1P



# Digital Linear Chargers

## Specifications

- Waterproof, shock-and vibration-resistant aluminum construction
- Saltwater tested and fully corrosion-resistant
- Short circuit, reverse polarity, and ignition protected
- For use with 12V/6 cell batteries that are flooded/wet cell, maintenance free or starved electrolyte (AGM) only
- FCC compliant
- UL listed to marine standard 1236
- 3 year warranty
- Replaces all existing current on-board chargers (excluding portables)
- No Price Increase
- Availability: November 2010



### DIGITAL LINEAR ON-BOARD CHARGERS

PRODUCT CODE	PRODUCT DESCRIPTION
1821065	MK 106D (1 bank x 6 amps)
1821105	MK-110D (1 bank x 10 amps)
1822105	MK-210D (2 bank x 5 amps)
1823155	MK-315D (3 bank x 5 amps)
1822205	MK-220D (2 bank x 10 amps)
1823305	MK-330D (3 bank x 10 amps)
1824405	MK-440D (4 bank x 10 amps)
1822305	MK-230D (2 bank x 15 amps)
1823455	MK-345D (3 bank x 15 amps)
1824605	MK-460D (4 bank x 15 amps)

# Digital Linear Chargers

## Specifications (cont.)

- New 4-color package design

minnkotamotors.com

**MINN KOTA**

**ON-BOARD MARINE BATTERY CHARGER**

DIGITALLY CONTROLLED 2X FASTER CHARGING PROTECTS BATTERIES

**Digital CONTROL**

**MK 210D**

2 CHARGING BANKS  
5 AMPS PER BANK  
10 AMPS TOTAL OUTPUT

**10 AMPS**

## CHARGING TECHNOLOGY

### CHARGING TECHNOLOGY

**DIGITALLY CONTROLLED.**  
Microprocessor design protects your batteries so you can stay on the water longer. It monitors temperature and state of charge to create a faster, regulated, more precise charge. Also includes automatic shut-off when charging is complete to extend battery life.

**DIGITALLY CONTROLLED.**  
Microprocessor design protects your batteries so you can stay on the water longer. It monitors temperature and state of charge to create a faster, regulated, more precise charge. Also includes automatic shut-off when charging is complete to extend battery life.

**ENHANCED STATUS CODES.**  
Provides comprehensive feedback on charge stage, maintenance mode status, error notification and full charge.

**ENHANCED STATUS CODES.**  
Provides comprehensive feedback on charge stage, maintenance mode status, error notification and full charge.

**Digital CONTROL**

**MULTI-STAGE CHARGING.**  
Delivers a fast, precise charge profile by automatically controlling current and voltage without overcharging your batteries.

**MULTI-STAGE CHARGING.**  
Delivers a fast, precise charge profile by automatically controlling current and voltage without overcharging your batteries.

**AUTOMATIC TEMPERATURE COMPENSATION.**  
Adjusts output voltage based on ambient temperature to ensure a full charge and protect your batteries.

**AUTOMATIC TEMPERATURE COMPENSATION.**  
Adjusts output voltage based on ambient temperature to ensure a full charge and protect your batteries.

**TIME (THREE STAGE CHARGER)**

**BATTERY CHARGER TEMPERATURE COMPENSATION**

absorption voltage (output voltage)

BATTERY TEMPERATURE (degrees F)

2010





# OUTLINE DIMENSIONS FOR SPVD-4000 OPEN

## TOP VIEW

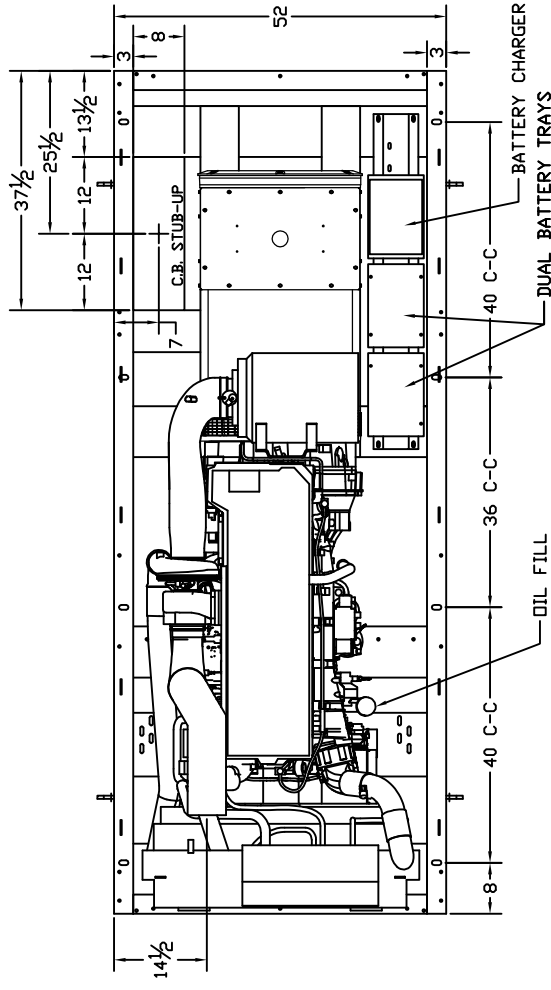

## RIGHT SIDE VIEW

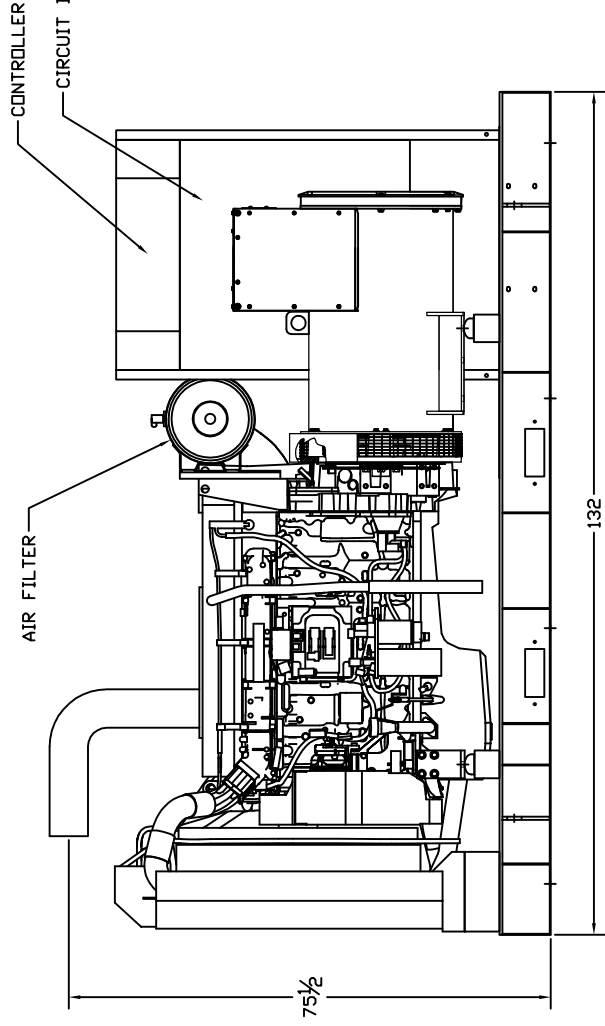

## RADIATOR END VIEW

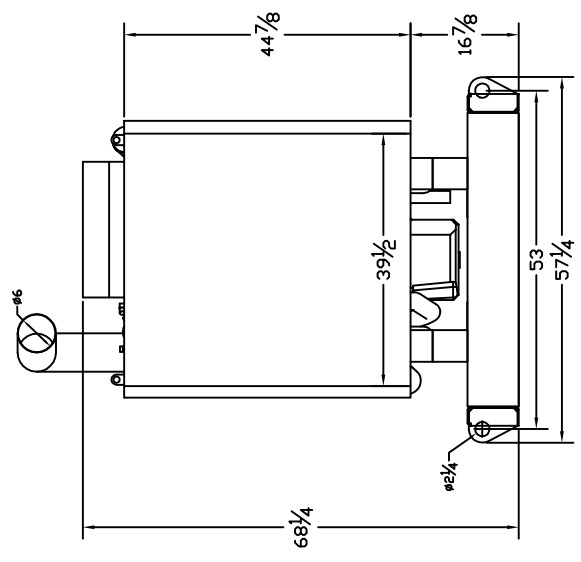

# OUTLINE DIMENSIONS FOR SPVD 250 - 400 KW LEVEL 2 ENCLOSURE (HINGED DOORS)

## TOP VIEW

(GEN-SET HAS (6) DOORS, (3) SHOWN OPEN ARE TYPICAL FOR BOTH SIDES)

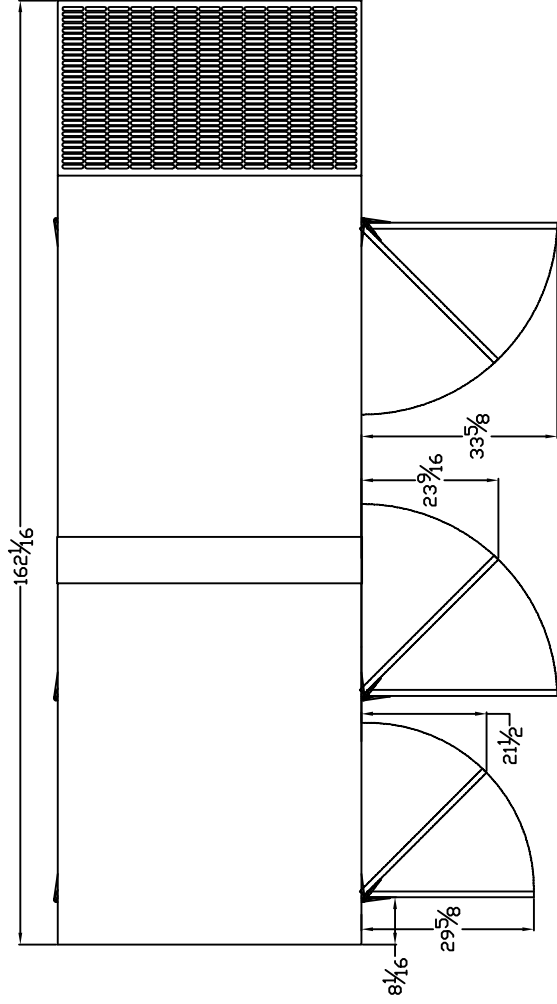

## FRAME VIEW

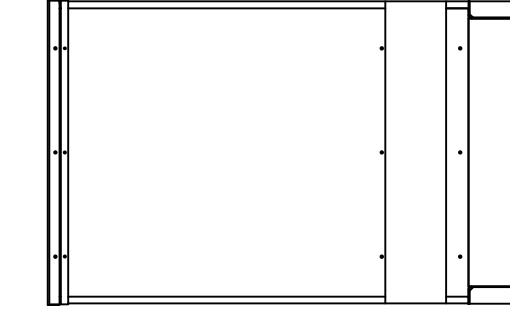
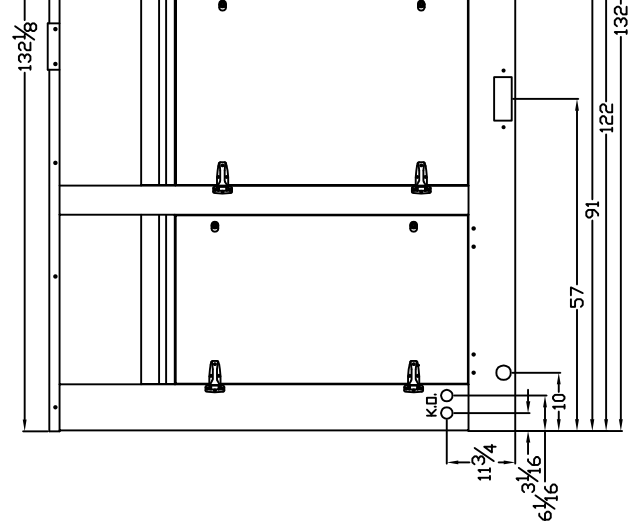
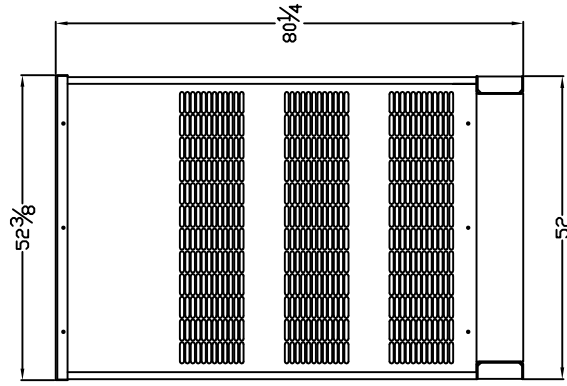
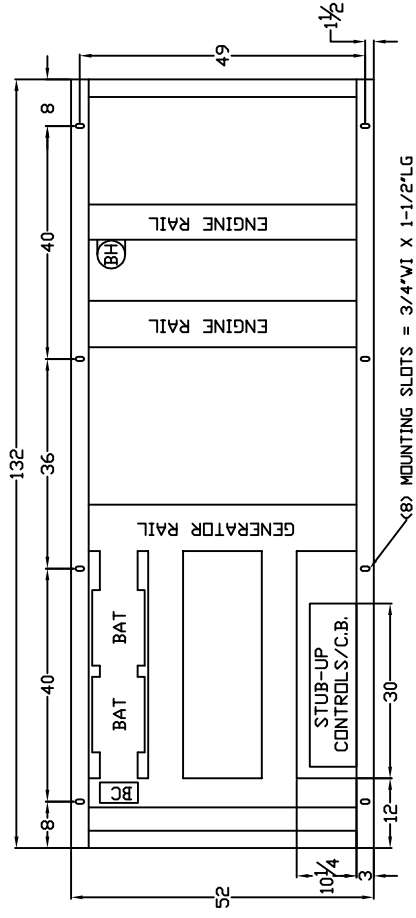

## GENERATOR END VIEW

## SIDE VIEW

## RADIATOR END VIEW