



# GILLETTE GENERATORS

60 HZ MODEL  
**SP-620**

**LIQUID COOLED LPG/NG ENGINE GENERATOR SET**

Model	STANDBY 120°C RISE		
	HZ	LPG	N.G.
<b>SP-620-60 HERTZ</b>	60	60/62	58/60



All generator sets are USA prototype built and thoroughly tested. Production models are USA factory built and 100% load tested.



**UL2200, UL1446, UL508, UL142, UL498**



**NFPA 110, 99, 70, 37**

All generator sets meet NFPA-110 Level 1, when equipped with the necessary accessories and installed per NFPA standards.



**NEC 700, 701, 702, 708**



**NEMA ICS10, MG1, ICS6, AB1**



**ANSI C62.41, 27, 59, 32, 480, 40Q, 81U, 360-05**



**ASCE 7-05 & 7-10**

All generator sets meet 180 MPH rating.



**EPA 40CFR Part 60, 1048, 1054, 1065, 1068**

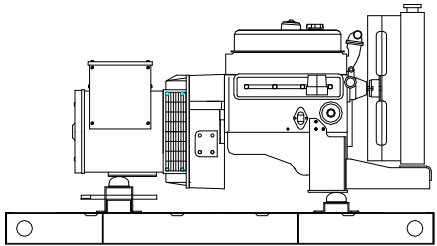

“OPEN” GEN-SET

There is no enclosure, so gen-set must be placed within a weather protected area, un-inhabited by humans or animals, with proper ventilation. Silencer not supplied, as installation requirements are not known. However, this item is available as optional equipment.

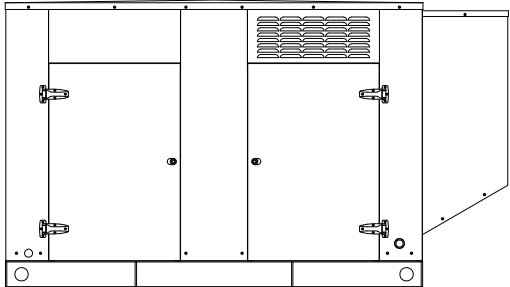

“LEVEL 2” HOUSED GEN-SET

Full aluminum weather protection and superior sound attenuation for specific low noise applications. Critical grade muffler is standard.

**GENERATOR RATINGS**

GENERATOR MODEL	VOLTAGE		PH	HZ	LIQUID PROPANE GAS FUEL		NATURAL GAS FUEL	
	L-N	L-L			120°C RISE STANDBY RATING		120°C RISE STANDBY RATING	
					KW/KVA	AMP	KW/KVA	AMP
<b>SP-620-1-1</b>	120	240	1	60	60/60	250	58/58	242
<b>SP-620-3-2</b>	120	208	3	60	62/77.5	215	60/75	208
<b>SP-620-3-3</b>	120	240	3	60	62/77.5	187	60/75	181
<b>SP-620-3-4</b>	277	480	3	60	62/77.5	93	60/75	90
<b>SP-620-3-5</b>	127	220	3	60	62/77.5	204	60/75	197
<b>SP-620-3-16</b>	346	600	3	60	62/77.5	74	60/75	72

RATINGS: All single phase gen-sets are dedicated 4 lead windings, rated at unity (1.0) power factor. All three phase gen-sets are 12 lead windings, rated at .8 power factor. 120°C “STANDBY RATINGS” are strictly for gen-sets that are used for back-up emergency power to a failed normal utility power source. This standby rating allows varying loads, with no overload capability, for the entire duration of utility power outage. All gen-set power ratings are based on temperature rise measured by resistance method as defined by MIL-STD 705C and IEEE STD 115, METHOD 6.4.4. All generators have class H (180°C) insulation system on both rotor and stator windings. All factory tests and KW/KVA charts shown above are based on 120°C (standby) R/R winding temperature, within a maximum 40°C ambient condition. Generators operated at standby power ratings must not exceed the temperature rise limitation for class H insulation system, as specified in NEMA MG1-22.40. Specifications & ratings are subject to change without prior notice.

# APPLICATION AND ENGINEERING DATA FOR MODEL SP-620-60 HZ

## GENERATOR SPECIFICATIONS

Manufacturer.....Stamford Electric Generators  
 Model & Type.....UCI224F-06, 4 Pole, 4 Lead, Single Phase  
 ..... UCI224F-311, 4 Pole, 12 Lead re-connectable, Three Phase  
 ..... UCI224F-17, 4 Pole, 6 Lead, 600V, Three Phase,  
 Exciter.....Brushless, shunt excited  
 Voltage Regulator ..... Solid State, HZ/Volts  
 Voltage Regulation ..... ½%, No load to full load  
 Frequency.....Field convertible, 60 HZ to 50 HZ  
 Frequency Regulation ..... ½% (½ cycle, no load to full load)  
 Unbalanced Load Capability..... 100% of standby amps  
 Total Stator and Load Insulation.....Class H, 180°C  
 Temperature Rise ..... 130°C R/R, standby rating @ 40°C amb.  
 1 Ø Motor Starting @ 30% Voltage Dip (240V) .....168 kVA  
 3 Ø Motor Starting @ 30% Voltage Dip (208-240V).....190 kVA  
 3 Ø Motor Starting @ 30% Voltage Dip (480V) .....260 kVA  
 3 Ø Motor Starting @ 30% Voltage Dip (600V) .....290 kVA  
 Bearing..... 1, Pre-lubed and sealed  
 Coupling..... Direct flexible disc  
 Total Harmonic Distortion ..... Max 3½% (MIL-STD705B)  
 Telephone Interference Factor ..... Max 50 (NEMA MG1-22)  
 Deviation Factor..... Max 5% (MIL-STD 405B)  
 Ltd. Warranty Period..... 24 Months from date of start-up or  
 ..... 1000 hours use, first to occur.

## GENERATOR FEATURES

- World Renown Stamford Electric Generator having UL-1446 certification.
- Full generator protection with **Deep Sea 7420** controller, having UL-508 certification.
- Automatic voltage regulator with over-excitation, under-frequency compensation, under-speed protection, and EMI filtering. Entire solid-state board is encapsulated for moisture protection.
- Generator power ratings are based on temperature rise, measured by resistance method, as defined in MIL-STD 705C and IEEE STD 115, Method 6.4.4.
- Power ratings will not exceed temperature rise limitation for class H insulation as per NEMA MG1-22.40.
- Insulation resistance to ground, exceeds 1.5 meg-ohm.
- Stator receives 2000 V. hi-potential test on main windings, and rotor windings receive a 1500 V. hi-potential test, as per MIL-STD 705B.
- Full amortisseur windings with UL-1446 certification.
- Complete engine-generator torsional acceptance, confirmed during initial prototype testing.
- Full load testing on all engine-generator sets, before shipping.
- Self ventilating and drip-proof & revolving field design

## ENGINE SPECIFICATIONS AND APPLICATIONS DATA

### ENGINE

Manufacturer.....Power Solutions, Inc (PSI)  
 Model and Type .....Ind. Power Train, 5.7L, 4 cycle  
 Aspiration..... Natural  
 Cylinder Arrangement.....8 Cylinders, V-8  
 Displacement Cu. In. (Liters).....350 (5.7)  
 Bore & Stroke In. (Cm.).....4 x 3.48 (10.2 x 8.84)  
 Compression Ratio..... 9.1:1  
 Main Bearings & Style..... 5M 400 Copper Lead  
 Cylinder Head .....Cast Iron  
 Pistons ..... High, Silicon Aluminum  
 Crankshaft .....Nodular Iron  
 Exhaust Valve ..... Forged Steel  
 Governor ..... Electronic  
 Frequency Reg. (no load-full load) ..... Isochronous  
 Frequency Reg. (steady state) ..... ± 1/4%  
 Air Cleaner.....Dry, Replaceable Cartridge  
 Engine Speed ..... 1800 rpm  
 Piston Speed, ft/min (m./min) ..... 1044 (318)  
 Max Power, bhp (kwm) Standby /LPG..... 108 (81)  
 Max Power, bhp (kwm) Standby/NG..... 100 (75)  
 Ltd. Warranty Period..... 12 Months or 2000 hrs., first to occur

### FUEL SYSTEM

Type .....LPG or NAT. GAS, Vapor Withdrawal  
 Fuel Pressure (kpa), in. H<sub>2</sub>O\* .....(1.74-2.74), 7"-11"  
 Secondary Fuel Regulator..... NG or LPG Vapor System  
 Auto Fuel Lock-Off Solenoid ..... Standard on all sets  
 Fuel Supply Inlet Line..... 1" NPTF  
 \* Measured at gen-set fuel inlet, downstream of any dry fuel accessories.

### FUEL CONSUMPTION

LP GAS: FT <sup>3</sup> /HR (M <sup>3</sup> /HR)	STANDBY
100% LOAD	330 (9.3)
75% LOAD	240 (7.0)
50% LOAD	195 (5.5)
<b>LPG = 2500 BTU X FT<sup>3</sup>/HR = Total BTU/HR</b>	
<b>LPG Conversion: 8.50 FT<sup>3</sup> = 1 LB. : 36.4 FT<sup>3</sup> = 1 GAL.</b>	

NAT. GAS: FT <sup>3</sup> /HR (M <sup>3</sup> /HR)	STANDBY
100% LOAD	800 (22.6)
75% LOAD	695 (20.0)
50% LOAD	500 (14.2)
<b>NG = 1000 BTU X FT<sup>3</sup>/HR = Total BTU/HR</b>	

### OIL SYSTEM

Type ..... Full Pressure  
 Oil Pan Capacity qt. (L) .....5.0 (4.7)  
 Oil Pan Cap. W/ filter qt. (L) .....6.5 (6.2)  
 Oil Filter..... 1, Replaceable Spin-On

### ELECTRICAL SYSTEM

Ignition System ..... Electronic  
 Eng. Alternator and Starter:  
     Ground ..... Negative  
     Volts DC ..... 12  
     Max. Amp Output of Alternator..... 70  
 Recommended Battery to -18°C (0°F):.. 12 VDC, Size BCI# 24F  
 Max Dimensions: ..10 3/4" lg X 6 3/4" wi X 9" hi, with standard round posts. Min. output at 600 CCA. Battery tray (max. dim. at 12"lg x 7"wi), hold down straps, battery cables, and battery charger, is furnished. Installation of (1) starting battery is required, with possible higher AMP/HR rating, as described above, if normal environment averages -13°F (-25°C) or cooler.

# APPLICATION AND ENGINEERING DATA FOR MODEL SP-620-60 HZ

## COOLING SYSTEM

Type of System .....	Pressurized, closed recovery
Coolant Pump .....	Pre-lubricated, self-sealing
Cooling Fan Type (no. of blades) .....	Pusher (10)
Fan Diameter inches (cm).....	21" (533)
Ambient Capacity of Radiator °F (°C).....	125 (51.6)
Engine Jacket Coolant Capacity Gal (L).....	1.8 (6.8)
Radiator Coolant Capacity Gal. (L) .....	5.2 (19.7)
Maximum Restriction of Cooling Air Intake and discharge side of radiator in. H <sub>2</sub> O (kpa).....	.5 (.125)
Water Pump Capacity gpm (L/min).....	27 (100)
Heat Reject Coolant: Btu/min (kw) .....	3200 (54.9)
Low Radiator Coolant Level Shutdown.....	Standard
Note: Coolant temp. shut-down switch setting at 212°F (100°C) with 50/50 (water/antifreeze) mix.	

## COOLING AIR REQUIREMENTS

Combustion Air, cfm (m <sup>3</sup> /min) .....	185 (5.2)
Radiator Air Flow cfm (m <sup>3</sup> /min) .....	6000 (170)
Heat Rejected to Ambient:	
Engine: kw (btu/min) .....	30.9 (1760)
Alternator: kw (btu/min).....	7.5 (430)

## EXHAUST SYSTEM

Exhaust Outlet Size.....	2.5"
Max. Back Pressure in. hg (KPA).....	3.0 (10.2)
Exhaust Flow, at rated kw: cfm (m <sup>3</sup> /min) .....	580 (16.5)
Exhaust Temp., at rated kw: °F (°C) .....	1200 (649)
Engines are EPA certified for LPG and Natural Gas.	

## SOUND LEVELS MEASURED IN dB(A)

	<u>Open Set</u>	<u>Level 2 Encl.</u>
Level 2, Critical Silencer .....	74.....	67
Level 3, Hospital Silencer.....		62

Note: Open sets (no enclosure) have silencer system choices due to unknown job-site applications. Level 2 enclosure has installed critical silencer with upgrade to Level 3 hospital silencer. Sound tests are averaged from several test points and taken at 23 ft. (7 m) from source of noise at normal operation.

## DERATE GENERATOR FOR ALTITUDE

3% per 1000 ft. (305m) above 3000 ft.(914m) from sea level

## DERATE GENERATOR FOR TEMPERATURE

2% per 10°F (5.6°C) above 104°F (40°C)

## DIMENSIONS AND WEIGHTS

	<u>Open Set</u>	<u>Level 2 Enclosure</u>
Length in (cm).....	78 (199) .....	94 (238)
Width in (cm).....	42 (107) .....	42 (107)
Height in (cm).....	38 (97) .....	53 (134)
1 Ø Net Weight lbs (kg).....	1931 (876) ....	2456 (1114)
1 Ø Ship Weight lbs (kg) .....	2031 (921) ....	2556 (1159)
3 Ø Net Weight lbs (kg).....	1891 (858) ....	2416 (1096)
3 Ø Ship Weight lbs (kg) .....	1991 (903) ....	2516 (1141)

# DEEP SEA 7420MKII DIGITAL MICROPROCESSOR CONTROLLER

## Deep Sea 7420MKII



The "7420MKII" controller is an auto start mains (utility) failure module for single gen-set applications. This controller includes a backlit LCD display which continuously displays the status of the engine and generator at all times.

The "7420MKII" controller will also monitor speed, frequency, voltage, current, oil pressure, coolant temp., and fuel levels. These modules have been designed to display warning and shut down status. It also includes: (11) configurable inputs • (8) configurable outputs • voltage monitoring • mains (utility) failure detection • (250) event logs • configurable timers • automatic shutdown or warning during fault detection • remote start (on load) • engine preheat • advanced metering capability • hour meter • text LCD 132 x 64 pixel ratio display • protected solid state outputs • test buttons for: stop/reset • manual mode • auto mode • lamp test • start button • power monitoring (kWh, kVAr, kVAh, kVAh) • IP65 rating (with supplied gasket)

This controller includes expansion features including RS232, RS484 (using MODBUS-RTU/TCP), direct USB connection with PC, expansion optioned using DSENet for remote annunciation and remote relay interfacing for a distance of up to 3300FT. The controller software is freely downloadable from the internet and allows monitoring with direct USB cable, LAN, or by internet via the built in web interface.

### Advanced Features:

PLC editor allow user configurable functions to meet specific application requirements • Data logging to assist with fault finding with 20 parameter data logging and recording on USB drives • Multiple date and time scheduler • Set maintenance periods can be configured to maintain optimum engine performance • Modules can be integrated into building management systems (BMS) using MODBUS • Configurable MODBUS pages with RTU & TCP support • Fully configurable via DSE Configuration Suite PC software • Remote SCADA monitoring via DSE Configuration Suite PC software • Engine exerciser • Automatic load transfer • Multiple configurations

# STANDARD FEATURES FOR MODEL SP-620-60HZ

## STANDARD FEATURES

### CONTROL PANEL:

- Deep Sea 7420 digital microprocessor with logic allows programming in the field. Controller has:
- STOP-MANUAL-AUTO modes and automatic engine shutdowns, signaled by full text LCD indicators:
  - Low oil pressure
  - High engine temp
  - Low Radiator Level
  - Three auxiliary alarms
  - Battery fail alarm
  - Engine fail to start
  - Engine over speed
  - Engine under speed
  - Over & under voltage
- Also included is tamper-proof engine hour meter

### ENGINE:

- Full flow oil filter • Air filter • Oil pump • Solenoid type starter motor • Hi-temp radiator • Jacket water pump
- Thermostat • Pusher fan and guard • Exhaust manifold
  - 12 VDC battery charging alternator • Flexible exhaust connector • "Isochronous" duty, electronic governor • Secondary dry fuel regulator • Dry fuel lock-off solenoid • Vibration isolators • Closed coolant recovery system with 50/50 water to anti-freeze mixture

### AC GENERATOR SYSTEM:

- AC generator • Shunt excited • Brushless design • Circuit Breaker installed and wired to gen-set • Direct connection to engine with flex disc • Class H, 180°C insulation • Self ventilated • Drip proof construction • UL Certified

### VOLTAGE REGULATOR:

- ½% Voltage regulation • EMI filter • Under-speed protection • Over-excitation protection • total encapsulation

### DC ELECTRICAL SYSTEM:

- Battery tray • Battery cables • Battery hold down straps • 2-stage battery float charger with maintaining & recharging automatic charge stages

### WEATHER/SOUND PROOF ALUMINUM HOUSING CORROSION RESISTANT PROTECTION CONSISTING OF:

- 9 Heated And Agitated Wash Stages
- Zinc Phosphate Etching-coating Stage
- Final Baked On Enamel Powder Coat
- 18/8 Stainless Steel Hardware

Design & specifications subject to change without prior notice. Dimensions shown are approximate. Contact Gillette for certified drawings.  
DO NOT USE DIMENSIONS FOR INSTALLATION PURPOSES.

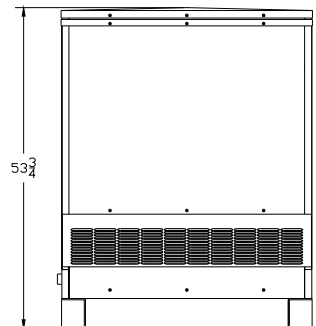
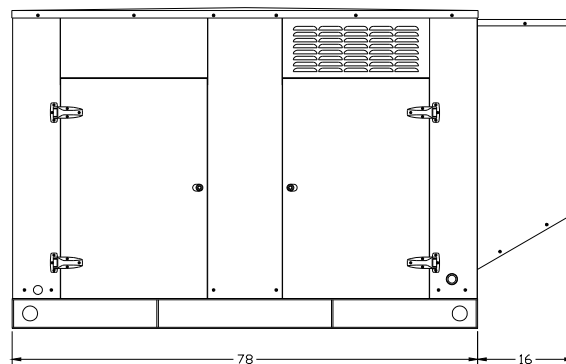
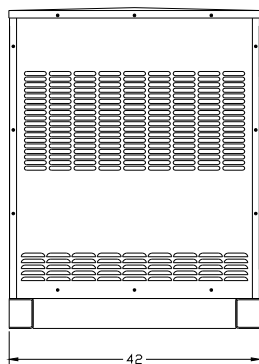
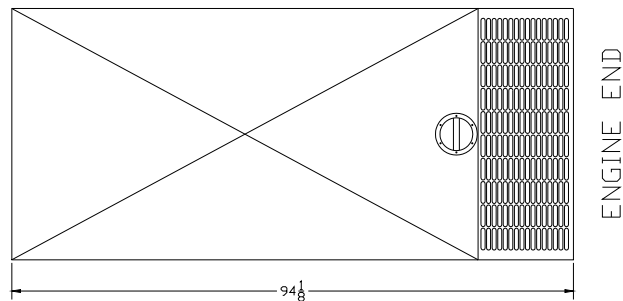

## GM Industrial Engine Power by Power Solutions, Inc.



### Feature/Benefits

- Designed to work with gasoline, liquid propane gas and natural gas.
- Nodular iron crankshaft has enlarged journal fillet radii for increased durability.
- World-class engine sealing system uses composite cylinder head gaskets with steel cores, a one-piece rear main crankshaft seal, a one-piece oil pan seal and moulded rocker cover seals.
- Hydraulic roller camshaft is optimized for maximum performance.
- Sintered powdered-metal exhaust valve seat inserts for enhanced durability.
- Exhaust valve rotators improve valve and valve seat durability.
- Positive inlet valve stem seals to control oil consumption.
- High Energy Ignition (HEI) distributor and coil and are standard.
- Common rear face on most GM industrial engines for easy hookup with housing.

### Options

- Cast iron 4 barrel intake manifold is standard.
- An Electronic control Module (ECM) utilizing state-of-the-art hybrid technology and related hardware to optimize fuel and spark requirements is available
- Fuel options LPG, NG
- SAE 3 flywheel housing (cast iron)
- SAE flywheels
- Custom made flywheels for numerous applications
- Cooling fans
- Radiators
- Dry type industrial air cleaners (safety element air cleaners available)
- Electric governor systems available - High Output Camshaft

### Power Solutions, Inc.

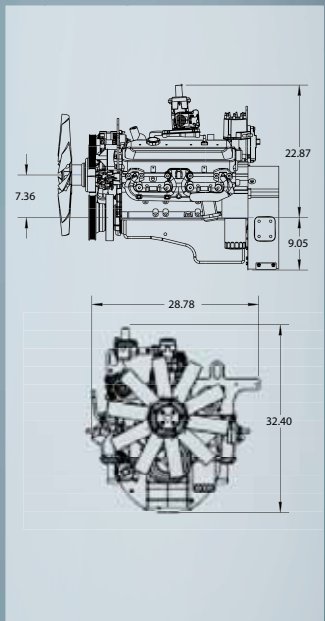

# PSI Offers Turn-Key Certified and Non-Certified Engine Packages

## Product Engineering Data

5.7L ENGINE

### General Data

**Type:** 90 5.7L V8  
**Displacement:** 350 cid (5736.50 cc)  
**Compression Ratio:** 9.4:1  
**Valve Configuration:** Pushrod Actuated Overhead Valves  
**Manufactured:** Toluca, Mexico  
**Valve Lifters:** Hydraulic Roller  
**Bore X Stroke:** 4.00 x 3.48 in (101.60 mm x 88.39 mm)  
**Main Bearing Caps:** 2-Bolt  
**Balance Method:** External  
**Intake Manifold:** Carburetor or Mixer  
**Oil Pan Capacity:** 5 qt  
**Fuel Types:** LPG or NG  
**Engine Rotation:** Clockwise (from the front)  
**Paint Protection:** Component Painted  
**Horsepower:** 201 hp @ 3000 rpm (Gasoline), 151 hp @ 3000 rpm (LP and natural gas)  
**Torque:** 320 lb-ft @ 2500 rpm (Gasoline), 272 lb-ft @ 2500 rpm (LP and natural gas)  
**Shipping Weight:** 582 lb (264 kg)

### Materials

**Block:** Cast Iron  
**Cylinder Head:** Cast Iron  
**Intake Manifold:** Cast Aluminum  
**Main Bearing Caps:** Cast Iron  
**Crankshaft:** Nodular Iron  
**Camshaft:** Cast Iron  
**Pistons:** High Silicon Content Aluminum  
**Exhaust Seat:** Sintered Powdered Metal Insert

### Engine Sealing System

One-piece viton rear main seal  
 One-piece oil pan gasket  
 Composite graphite cylinder head gaskets with stainless steel core  
 Non-asbestos gaskets throughout

### Fuel System Options

#### Closed-Loop Fuel System Kit Dual Fuel

**LPG** (Mixer, Throttle Body, Fuel Lock, Regulator)

**LPG W/Governor** (Same As Above w/Elec. Governor)

**LPG W/Governor** (Same As Above w/Velocity Governor)

**LPG Carb**

**NG/LPG Carb Dual Fuel**

**NG Carb**

**NG** (Mixer, Throttle Body & Air Cleaner)

**NG W/Governor** (Same As Above w/Elec. Governor)

**Three Way Catalyst Available**

#### GASOLINE, FUEL INJECTION

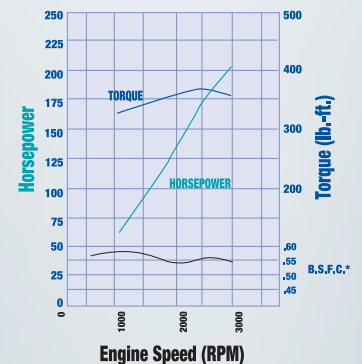

Power corrected to SAE J1995. Actual power levels may vary due to fuel system calibration, and design of induction and exhaust system

#### LP, CARBURETED

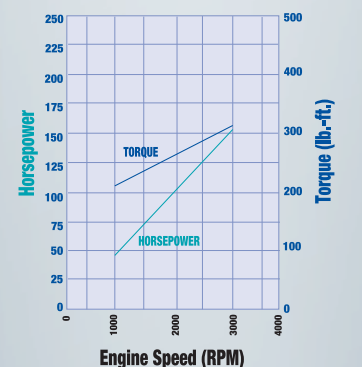

Power corrected to SAE J1995. Actual power levels may vary due to fuel system calibration, and design of induction and exhaust system

#### NATURAL GAS, CARBURETED

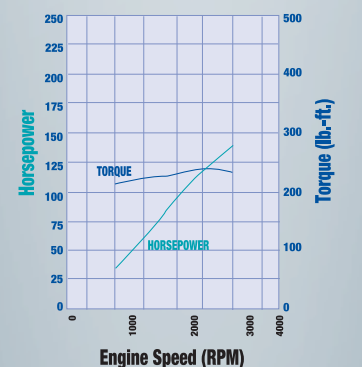

Power corrected to SAE J1995. Actual power levels may vary due to fuel system calibration, and design of induction and exhaust system



655 Wheat Lane, Wood Dale, IL 60191  
 Telephone 630-350-9400  
 Fax 630-350-9900  
 www.psiengines.com



Information may vary with application. All specifications listed are based on the latest product information available at the time of publication. The right is reserved to make changes at any time without notice.

# STAMFORD<sup>®</sup>

**UCI224F - Winding 06**

Technical Data Sheet

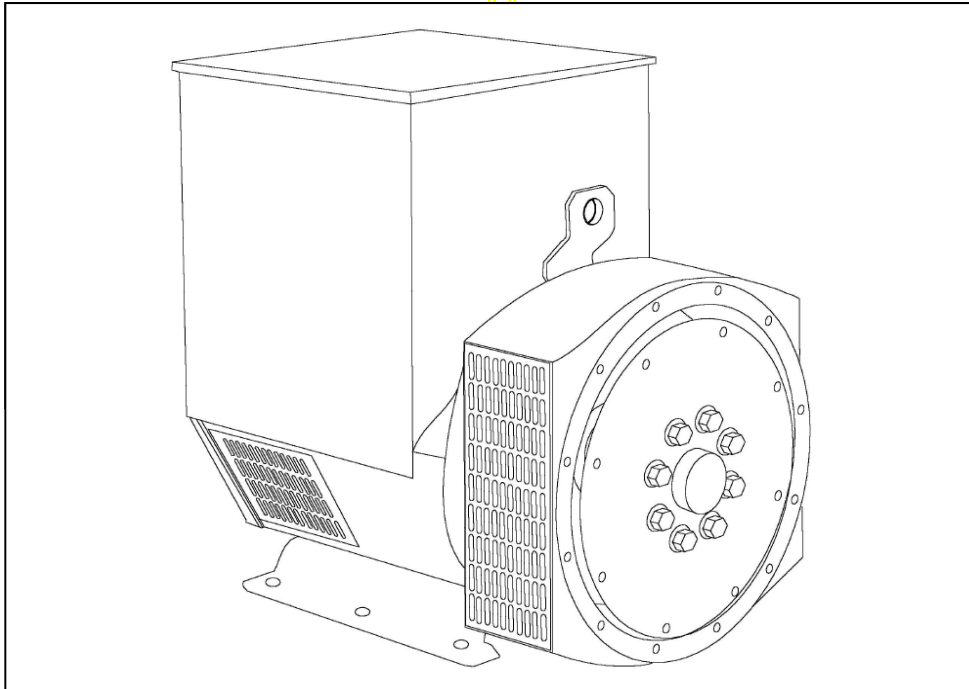

## SPECIFICATIONS &amp; OPTIONS

**STANDARDS**

Stamford industrial generators meet the requirements of BS EN 60034 and the relevant section of other international standards such as BS5000, VDE 0530, NEMA MG1-32, IEC34, CSA C22.2-100, AS1359. Other standards and certifications can be considered on request.

**VOLTAGE REGULATORS****SX460 AVR - STANDARD**

With this self excited control system the main stator supplies power via the Automatic Voltage Regulator (AVR) to the exciter stator. The high efficiency semiconductors of the AVR ensure positive build-up from initial low levels of residual voltage.

The exciter rotor output is fed to the main rotor through a three phase full wave bridge rectifier. This rectifier is protected by a surge suppressor against surges caused, for example, by short circuit.

**AS440 AVR**

With this self-excited system the main stator provides power via the AVR to the exciter stator. The high efficiency semi-conductors of the AVR ensure positive build-up from initial low levels of residual voltage.

The exciter rotor output is fed to the main rotor through a three-phase full-wave bridge rectifier. The rectifier is protected by a surge suppressor against surges caused, for example, by short circuit or out-of-phase paralleling.

The AS440 will support a range of electronic accessories, including a 'droop' Current Transformer (CT) to permit parallel operation with other ac generators.

**MX341 AVR**

This sophisticated AVR is incorporated into the Stamford Permanent Magnet Generator (PMG) control system.

The PMG provides power via the AVR to the main exciter, giving a source of constant excitation power independent of generator output. The main exciter output is then fed to the main rotor, through a full wave bridge, protected by a surge suppressor. The AVR has in-built protection against sustained over-excitation, caused by internal or external faults. This de-excites the machine after a minimum of 5 seconds.

An engine relief load acceptance feature can enable full load to be applied to the generator in a single step.

**MX321 AVR**

The most sophisticated of all our AVRs combines all the features of the MX341 with, additionally over voltage protection built-in and short circuit current level adjustments as an optional facility.

**WINDINGS & ELECTRICAL PERFORMANCE**

All generator stators are wound to 2/3 pitch. This eliminates triplen (3rd, 9th, 15th ...) harmonics on the voltage waveform and is found to be the optimum design for trouble-free supply of non-linear loads. The 2/3 pitch design avoids excessive neutral currents sometimes seen with higher winding pitches, when in parallel with the mains. A fully connected damper winding reduces oscillations during paralleling. This winding, with the 2/3 pitch and carefully selected pole and tooth designs, ensures very low waveform distortion.

**TERMINALS & TERMINAL BOX**

Dedicated Single Phase windings have 4 ends brought out to the terminals, which are mounted on a cover at the non-drive end of the generator. A sheet steel terminal box contains the AVR and provides ample space for the customers' wiring and gland arrangements. It has removable panels for easy access.

**SHAFT & KEYS**

All generator rotors are dynamically balanced to better than BS6861:Part 1 Grade 2.5 for minimum vibration in operation. Two bearing generators are balanced with a half key.

**INSULATION/IMPREGNATION**

The insulation system is class 'H'.

All wound components are impregnated with materials and processes designed specifically to provide the high build required for static windings and the high mechanical strength required for rotating components.

**QUALITY ASSURANCE**

Generators are manufactured using production procedures having a quality assurance level to BS EN ISO 9001.

The stated voltage regulation may not be maintained in the presence of certain radio transmitted signals. Any change in performance will fall within the limits of Criteria 'B' of EN 61000-6-2:2001. At no time will the steady-state voltage regulation exceed 2%.

**DE RATES**

All values tabulated on page 7 are subject to the following reductions

5% when air inlet filters are fitted.

3% for every 500 metres by which the operating altitude exceeds 1000 metres above mean sea level.

3% for every 5 C by which the operational ambient temperature exceeds 40 C.

Note: Requirement for operating in an ambient exceeding 60 C must be referred to the factory.

*NB Continuous development of our products entitles us to change specification details without notice, therefore they must not be regarded as binding.*

*Front cover drawing typical of product range.*



## WINDING 06

CONTROL SYSTEM	SEPARATELY EXCITED BY P.M.G.		
A.V.R.	MX341	MX321	
VOLTAGE REGULATION	± 1%	± 0.5 %	With 4% ENGINE GOVERNING
SUSTAINED SHORT CIRCUIT	REFER TO SHORT CIRCUIT DECREMENT CURVES (page 6)		

CONTROL SYSTEM	SELF EXCITED		
A.V.R.	SX460	AS440	
VOLTAGE REGULATION	± 1.0 %	± 1.0 %	With 4% ENGINE GOVERNING
SUSTAINED SHORT CIRCUIT	SERIES 4 CONTROL DOES NOT SUSTAIN A SHORT CIRCUIT CURRENT		

INSULATION SYSTEM	CLASS H		
PROTECTION	IP23		
RATED POWER FACTOR	0.8		
STATOR WINDING	SINGLE LAYER CONCENTRIC		
WINDING PITCH	TWO THIRDS		
WINDING LEADS	4		
MAIN STATOR RESISTANCE	0.024 Ohms AT 22°C SERIES CONNECTED		
MAIN ROTOR RESISTANCE	0.83 Ohms at 22°C		
EXCITER STATOR RESISTANCE	20 Ohms at 22°C		
EXCITER ROTOR RESISTANCE	0.078 Ohms PER PHASE AT 22°C		
R.F.I. SUPPRESSION	BS EN 61000-6-2 & BS EN 61000-6-4, VDE 0875G, VDE 0875N. refer to factory for others		
WAVEFORM DISTORTION	NO LOAD < 1.5% NON-DISTORTING LINEAR LOAD < 5.0%		
MAXIMUM OVERSPEED	2250 Rev/Min		
BEARING DRIVE END	BALL. 6312-2RS (ISO)		
BEARING NON-DRIVE END	BALL. 6309-2RS (ISO)		

	1 BEARING	2 BEARING
WEIGHT COMP. GENERATOR	337 kg	350 kg
WEIGHT WOUND STATOR	120 kg	120 kg
WEIGHT WOUND ROTOR	110.7 kg	102.3 kg
WR <sup>2</sup> INERTIA	0.6071 kgm <sup>2</sup>	0.5754 kgm <sup>2</sup>
SHIPPING WEIGHTS in a crate	360 kg	371 kg
PACKING CRATE SIZE	105 x 57 x 96(cm)	105 x 57 x 96(cm)
TELEPHONE INTERFERENCE	THF<2%	TIF<50

COOLING AIR	0.281 m <sup>3</sup> /sec 595 cfm		
VOLTAGE SERIES	220	230	240
VOLTAGE PARALLEL	110	115	120
kVA BASE RATING FOR REACTANCE VALUES	60	60	60
X <sub>d</sub> DIR. AXIS SYNCHRONOUS	2.95	2.70	2.48
X' <sub>d</sub> DIR. AXIS TRANSIENT	0.24	0.22	0.20
X'' <sub>d</sub> DIR. AXIS SUBTRANSIENT	0.17	0.15	0.14
X <sub>q</sub> QUAD. AXIS REACTANCE	1.36	1.25	1.14
X'' <sub>q</sub> QUAD. AXIS SUBTRANSIENT	0.15	0.14	0.13
X <sub>L</sub> LEAKAGE REACTANCE	0.09	0.08	0.07
X <sub>2</sub> NEGATIVE SEQUENCE	0.15	0.14	0.13
X <sub>0</sub> ZERO SEQUENCE	0.11	0.10	0.10

REACTANCES ARE SATURATED

T' <sub>d</sub> TRANSIENT TIME CONST.	0.03s
T'' <sub>d</sub> SUB-TRANSTIME CONST.	0.008s
T' <sub>do</sub> O.C. FIELD TIME CONST.	0.75s
T <sub>a</sub> ARMATURE TIME CONST.	0.0065s
SHORT CIRCUIT RATIO	1/X <sub>d</sub>

**UCI224F**  
Winding 06

**STAMFORD**

**SINGLE PHASE EFFICIENCY CURVES**

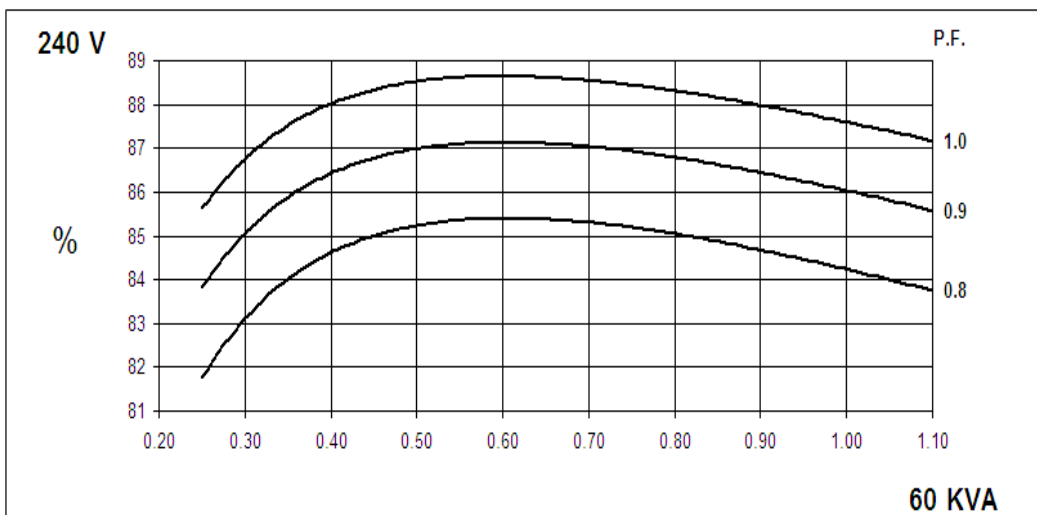
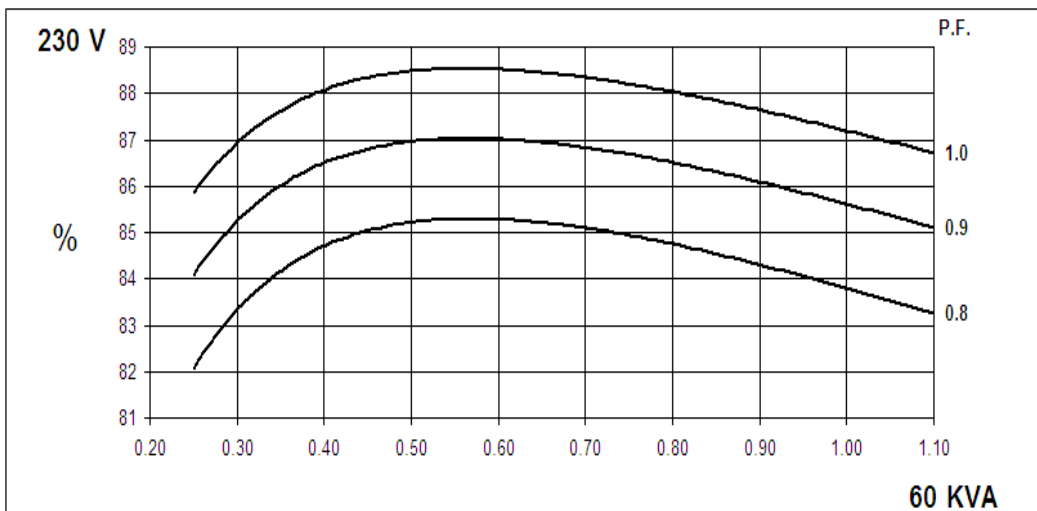
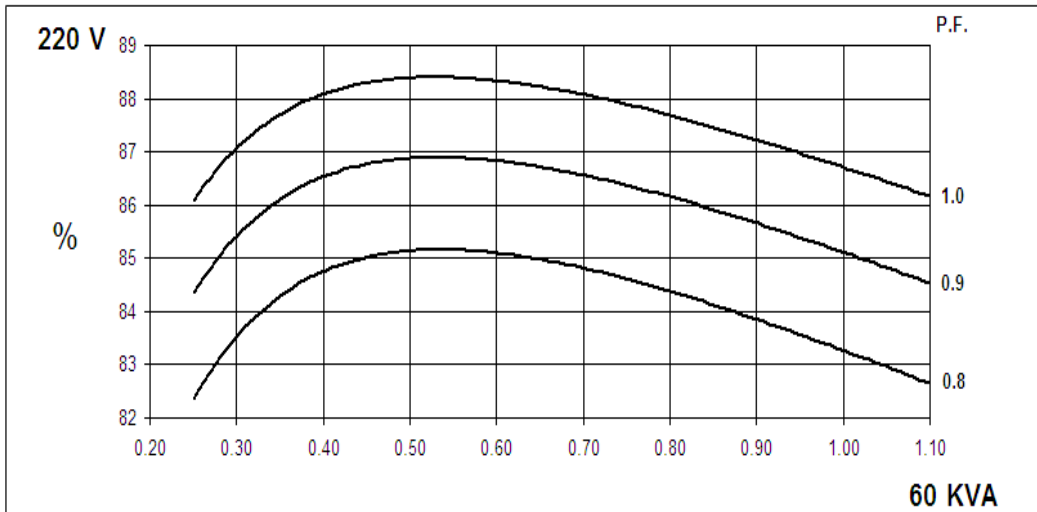

**UCI224F**  
Winding 06

**STAMFORD**

**SX**

**Locked Rotor Motor Starting Curves**

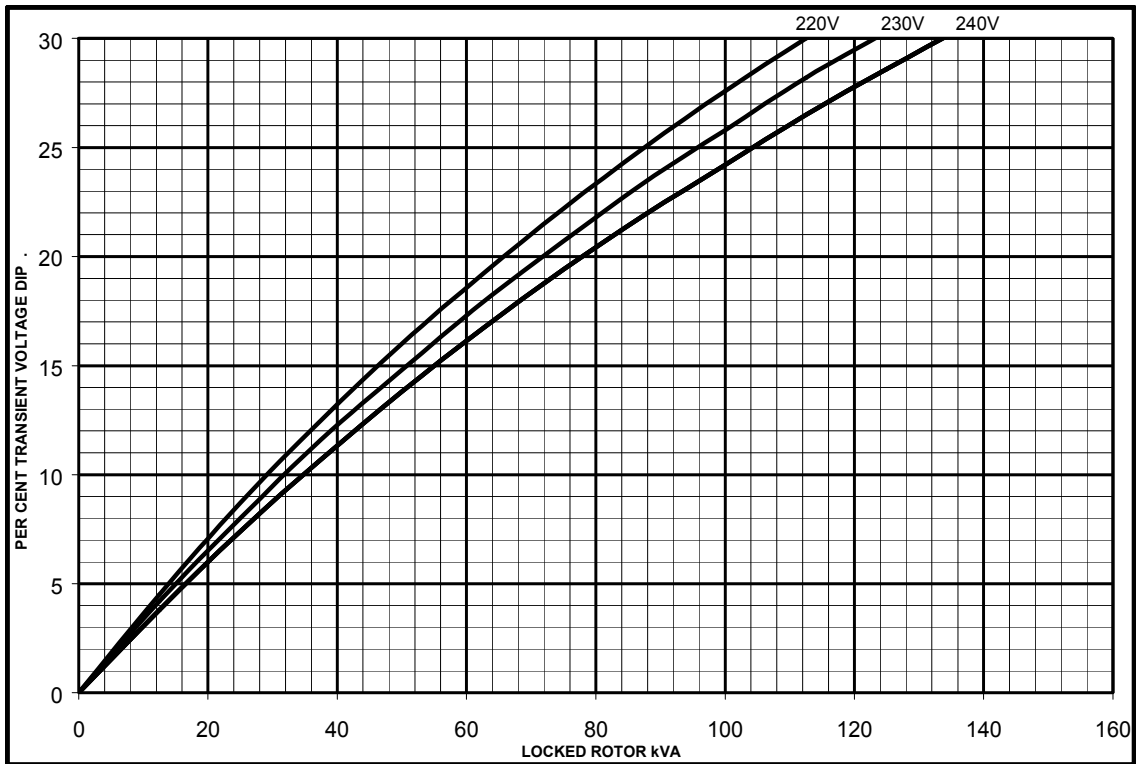

OCU

**MX**

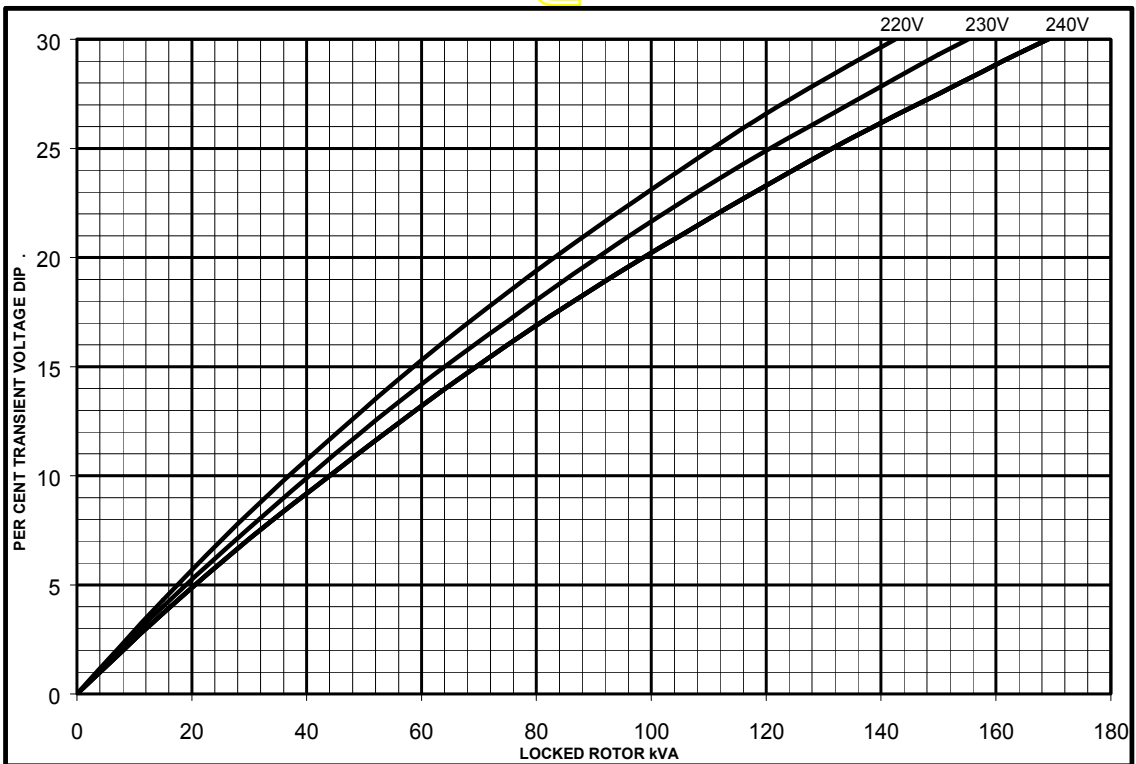

**UCI224F**  
Winding 06

**STAMFORD**

**Short Circuit Decrement Curve. No-load Excitation at Rated Speed  
Based on series connection.**

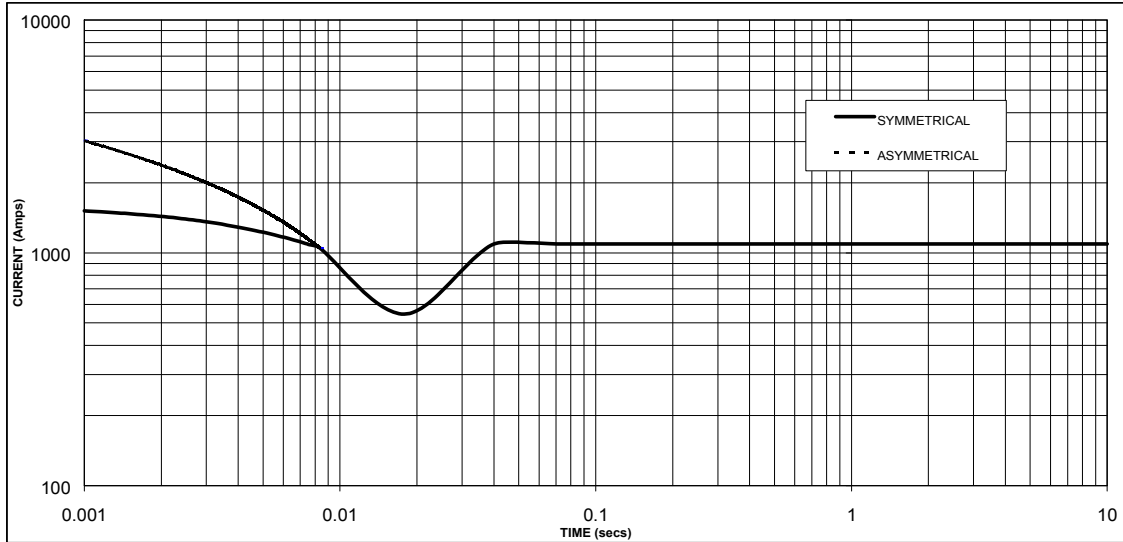

Sustained Short Circuit = 1090 Amps

**Note**

The following multiplication factors should be used to adjust the values from curve between time 0.001 seconds and the minimum current point in respect of nominal operating voltage :

Voltage	Factor
220V	X 1.00
230V	X 1.05
240V	X 1.09

The sustained current value is constant irrespective of voltage level

MEDDUS

# UCI224F

**STAMFORD**

Winding 06

**60Hz**

## RATINGS

Class - Temp Rise	Cont. F - 105/40°C			Cont. H - 125/40°C			Cont. F - 105/40°C			Cont. H - 125/40°C		
	0.8pf			0.8pf			1.0pf			1.0pf		
Series (V)	220	230	240	220	230	240	220	230	240	220	230	240
Parallel (V)	110	115	120	110	115	120	110	115	120	110	115	120
kVA	56.9	56.9	56.9	60.0	60.0	60.0	56.9	56.9	56.9	60.0	60.0	60.0
kW	45.5	45.5	45.5	48.0	48.0	48.0	56.9	56.9	56.9	60.0	60.0	60.0
Efficiency (%)	83.6	84.1	84.5	83.3	83.8	84.2	87.0	87.4	87.8	86.7	87.2	87.6
kW Input	54.5	54.2	53.9	57.6	57.3	57.0	65.4	65.1	64.8	69.2	68.8	68.5

## APPROXIMATE DIMENSIONS

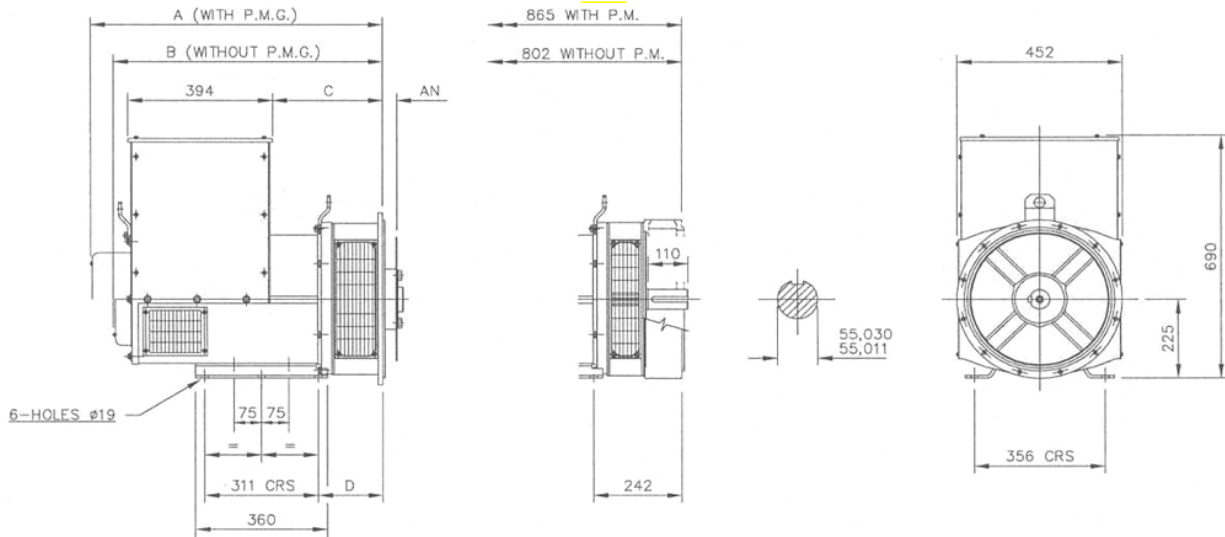

SINGLE BEARING MACHINES ONLY						
ADAPTOR	A	B	C	D	COUPLING DISCS	AN
SAE 1	814,3	751,3	314,3	191,3	SAE 8	61,90
SAE 2	800	737	300	177	SAE 10	53,98
SAE 3	800	737	300	177	SAE 11,5	39,68
SAE 4	800	737	300	177	SAE 14	25,40

APPROVED DOCUMENT

**STAMFORD**

Head Office Address:  
Barnack Road, Stamford  
Lincolnshire, PE9 2NB  
United Kingdom  
Tel: +44 (0) 1780 484000  
Fax: +44 (0) 1780 484100

[www.cumminsgeneratortechnologies.com](http://www.cumminsgeneratortechnologies.com)

Copyright 2010, Cummins Generator Technologies Ltd, All Rights Reserved  
Stamford and AvK are registered trade marks of Cummins Generator Technologies Ltd  
Cummins and the Cummins logo are registered trade marks of Cummins Inc.

# STAMFORD<sup>®</sup>

**UCI224F - Winding 311**

Technical **VA** Data Sheet

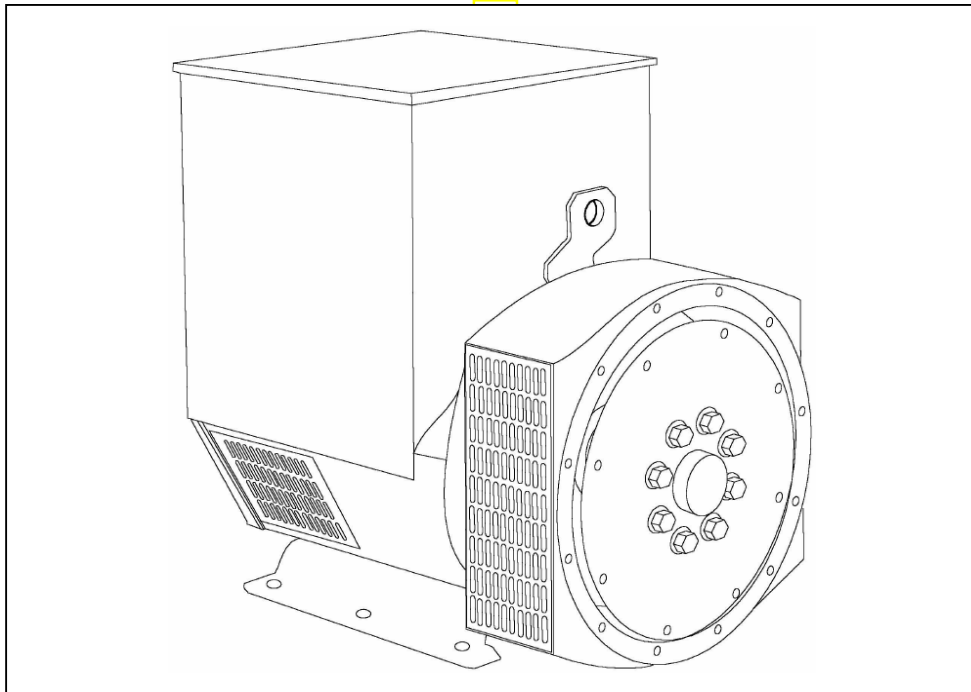

## SPECIFICATIONS &amp; OPTIONS

## STANDARDS

Stamford industrial generators meet the requirements of BS EN 60034 and the relevant section of other international standards such as BS5000, VDE 0530, NEMA MG1-32, IEC34, CSA C22.2-100, AS1359.

Other standards and certifications can be considered on request.

## VOLTAGE REGULATORS

## SX460 AVR - STANDARD

With this self excited control system the main stator supplies power via the Automatic Voltage Regulator (AVR) to the exciter stator. The high efficiency semiconductors of the AVR ensure positive build-up from initial low levels of residual voltage.

The exciter rotor output is fed to the main rotor through a three phase full wave bridge rectifier. This rectifier is protected by a surge suppressor against surges caused, for example, by short circuit.

## AS440 AVR

With this self-excited system the main stator provides power via the AVR to the exciter stator. The high efficiency semiconductors of the AVR ensure positive build-up from initial low levels of residual voltage.

The exciter rotor output is fed to the main rotor through a three-phase full-wave bridge rectifier. The rectifier is protected by a surge suppressor against surges caused, for example, by short circuit or out-of-phase paralleling.

The AS440 will support a range of electronic accessories, including a 'droop' Current Transformer (CT) to permit parallel operation with other ac generators.

## MX341 AVR

This sophisticated AVR is incorporated into the Stamford Permanent Magnet Generator (PMG) control system.

The PMG provides power via the AVR to the main exciter, giving a source of constant excitation power independent of generator output. The main exciter output is then fed to the main rotor, through a full wave bridge, protected by a surge suppressor. The AVR has in-built protection against sustained over-excitation, caused by internal or external faults. This de-excites the machine after a minimum of 5 seconds.

An engine relief load acceptance feature can enable full load to be applied to the generator in a single step.

If three-phase sensing is required with the PMG system the MX321 AVR must be used.

We recommend three-phase sensing for applications with greatly unbalanced or highly non-linear loads.

## MX321 AVR

The most sophisticated of all our AVRs combines all the features of the MX341 with, additionally, three-phase rms sensing, for improved regulation and performance.

Over voltage protection is built-in and short circuit current level adjustments is an optional facility.

## WINDINGS &amp; ELECTRICAL PERFORMANCE

All generator stators are wound to 2/3 pitch. This eliminates triplen (3rd, 9th, 15th ...) harmonics on the voltage waveform and is found to be the optimum design for trouble-free supply of non-linear loads. The 2/3 pitch design avoids excessive neutral currents sometimes seen with higher winding pitches, when in parallel with the mains. A fully connected damper winding reduces oscillations during paralleling. This winding, with the 2/3 pitch and carefully selected pole and tooth designs, ensures very low waveform distortion.

## TERMINALS &amp; TERMINAL BOX

Standard generators are 3-phase reconnectable with 12 ends brought out to the terminals, which are mounted on a cover at the non-drive end of the generator. A sheet steel terminal box contains the AVR and provides ample space for the customers' wiring and gland arrangements. It has removable panels for easy access.

## SHAFT &amp; KEYS

All generator rotors are dynamically balanced to better than BS6861:Part 1 Grade 2.5 for minimum vibration in operation.

## INSULATION/IMPREGNATION

The insulation system is class 'H'.

All wound components are impregnated with materials and processes designed specifically to provide the high build required for static windings and the high mechanical strength required for rotating components.

## QUALITY ASSURANCE

Generators are manufactured using production procedures having a quality assurance level to BS EN ISO 9001.

The stated voltage regulation may not be maintained in the presence of certain radio transmitted signals. Any change in performance will fall within the limits of Criteria 'B' of EN 61000-6-2:2001. At no time will the steady-state voltage regulation exceed 2%.

## DE RATES

All values tabulated on page 8 are subject to the following reductions

5% when air inlet filters are fitted.

3% for every 500 metres by which the operating altitude exceeds 1000 metres above mean sea level.

3% for every 5°C by which the operational ambient temperature exceeds 40°C.

Note: Requirement for operating in an ambient exceeding 60°C must be referred to the factory.

*NB Continuous development of our products entitles us to change specification details without notice, therefore they must not be regarded as binding.*

*Front cover drawing typical of product range.*

APPROVED DOCUMENT



**WINDING 311**

CONTROL SYSTEM	SEPARATELY EXCITED BY P.M.G.							
A.V.R.	MX321	MX341						
VOLTAGE REGULATION	± 0.5 %	± 1.0 %	With 4% ENGINE GOVERNING					
SUSTAINED SHORT CIRCUIT	REFER TO SHORT CIRCUIT DECREMENT CURVES (page 7)							
CONTROL SYSTEM	SELF EXCITED							
A.V.R.	SX460	AS440						
VOLTAGE REGULATION	± 1.0 %	± 1.0 %	With 4% ENGINE GOVERNING					
SUSTAINED SHORT CIRCUIT	SERIES 4 CONTROL DOES NOT SUSTAIN A SHORT CIRCUIT CURRENT							
INSULATION SYSTEM	CLASS H							
PROTECTION	IP23							
RATED POWER FACTOR	0.8							
STATOR WINDING	DOUBLE LAYER CONCENTRIC							
WINDING PITCH	TWO THIRDS							
WINDING LEADS	12							
STATOR WDG. RESISTANCE	0.065 Ohms PER PHASE AT 22°C SERIES STAR CONNECTED							
ROTOR WDG. RESISTANCE	0.83 Ohms at 22°C							
EXCITER STATOR RESISTANCE	20 Ohms at 22°C							
EXCITER ROTOR RESISTANCE	0.078 Ohms PER PHASE AT 22°C							
R.F.I. SUPPRESSION	BS EN 61000-6-2 & BS EN 61000-6-4,VDE 0875G, VDE 0875N. refer to factory for others							
WAVEFORM DISTORTION	NO LOAD < 1.5% NON-DISTORTING BALANCED LINEAR LOAD < 5.0%							
MAXIMUM OVERSPEED	2250 Rev/Min							
BEARING DRIVE END	BALL. 6312-2RS (ISO)							
BEARING NON-DRIVE END	BALL. 6309-2RS (ISO)							
	1 BEARING				2 BEARING			
WEIGHT COMP. GENERATOR	337 kg				350 kg			
WEIGHT WOUND STATOR	120 kg				120 kg			
WEIGHT WOUND ROTOR	110.69 kg				102.32 kg			
WR <sup>2</sup> INERTIA	0.6071 kgm <sup>2</sup>				0.5754 kgm <sup>2</sup>			
SHIPPING WEIGHTS in a crate	360 kg				371 kg			
PACKING CRATE SIZE	105 x 57 x 96(cm)				105 x 57 x 96(cm)			
	50 Hz				60 Hz			
TELEPHONE INTERFERENCE	THF<2%				TIF<50			
COOLING AIR	0.216 m <sup>3</sup> /sec 458 cfm				0.281 m <sup>3</sup> /sec 595 cfm			
VOLTAGE SERIES STAR	380/220	400/231	415/240	440/254	416/240	440/254	460/266	480/277
VOLTAGE PARALLEL STAR	190/110	200/115	208/120	220/127	208/120	220/127	230/133	240/138
VOLTAGE SERIES DELTA	220/110	230/115	240/120	254/127	240/120	254/127	266/133	277/138
KVA BASE RATING FOR REACTANCE VALUES	72.5	72.5	72.5	55	83.8	87.5	87.5	93.8
X <sub>d</sub> DIR. AXIS SYNCHRONOUS	2.29	2.07	1.92	1.30	2.52	2.35	2.15	2.12
X' <sub>d</sub> DIR. AXIS TRANSIENT	0.18	0.16	0.15	0.10	0.21	0.20	0.18	0.18
X'' <sub>d</sub> DIR. AXIS SUBTRANSIENT	0.12	0.11	0.10	0.07	0.14	0.13	0.12	0.12
X <sub>q</sub> QUAD. AXIS REACTANCE	1.05	0.95	0.88	0.59	1.16	1.08	0.99	0.98
X'' <sub>q</sub> QUAD. AXIS SUBTRANSIENT	0.16	0.14	0.13	0.09	0.13	0.12	0.11	0.11
X <sub>L</sub> LEAKAGE REACTANCE	0.07	0.06	0.06	0.04	0.08	0.07	0.07	0.07
X <sub>2</sub> NEGATIVE SEQUENCE	0.14	0.13	0.12	0.08	0.13	0.12	0.11	0.11
X <sub>0</sub> ZERO SEQUENCE	0.11	0.10	0.09	0.06	0.10	0.09	0.09	0.08
REACTANCES ARE SATURATED				VALUES ARE PER UNIT AT RATING AND VOLTAGE INDICATED				
T' <sub>d</sub> TRANSIENT TIME CONST.	0.03 s							
T'' <sub>d</sub> SUB-TRANSTIME CONST.	0.008 s							
T' <sub>do</sub> O.C. FIELD TIME CONST.	0.75 s							
T <sub>a</sub> ARMATURE TIME CONST.	0.0065 s							
SHORT CIRCUIT RATIO	1/X <sub>d</sub>							

**50  
Hz**

**UCI224F**  
Winding 311

**STAMFORD**

**THREE PHASE EFFICIENCY CURVES**

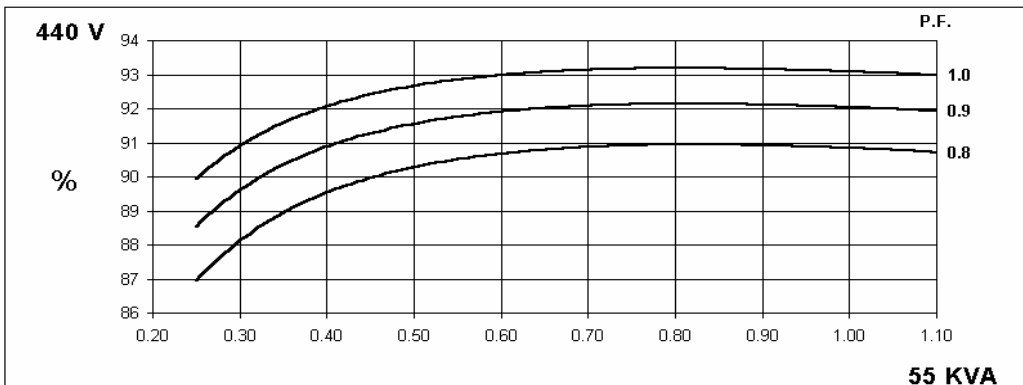
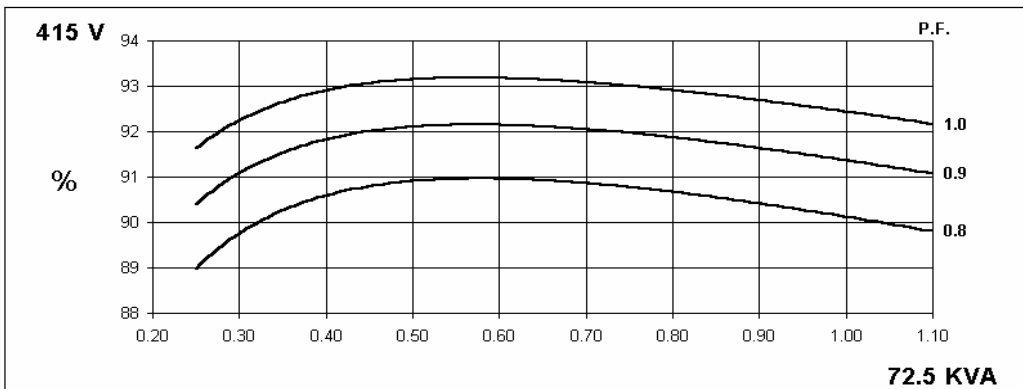
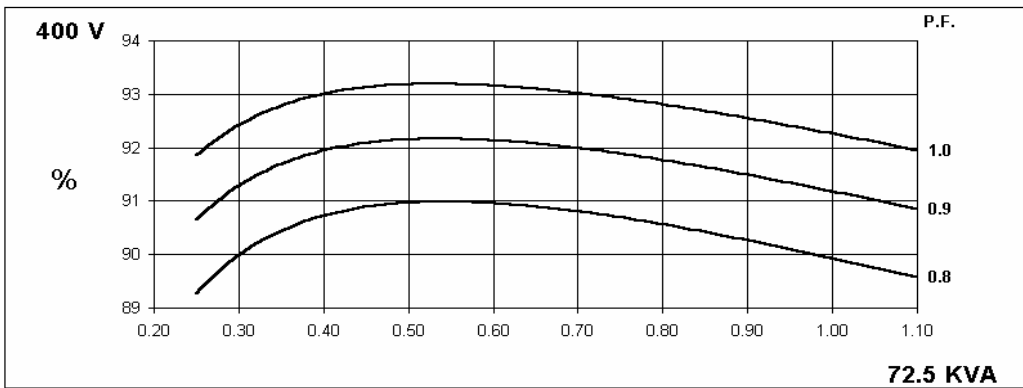
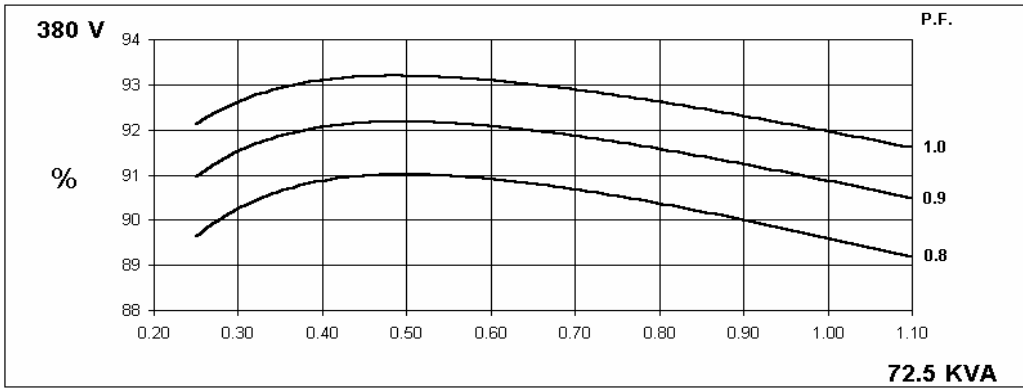

**60  
Hz**

**UCI224F**  
Winding 311

**STAMFORD**

**THREE PHASE EFFICIENCY CURVES**

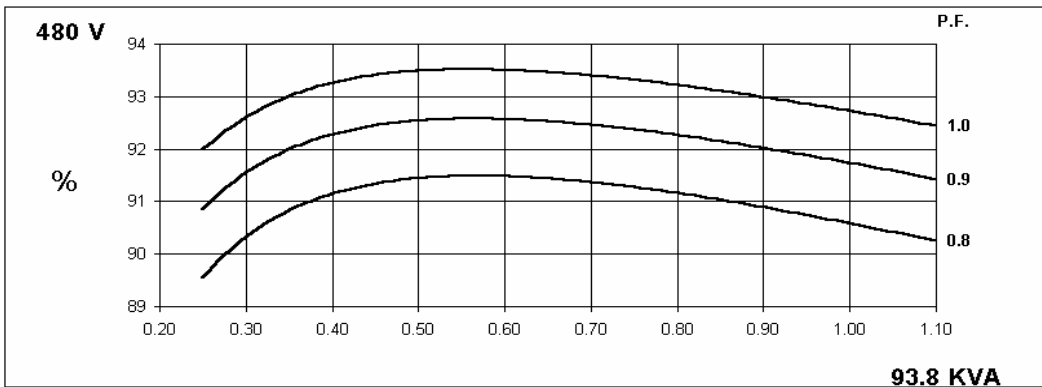
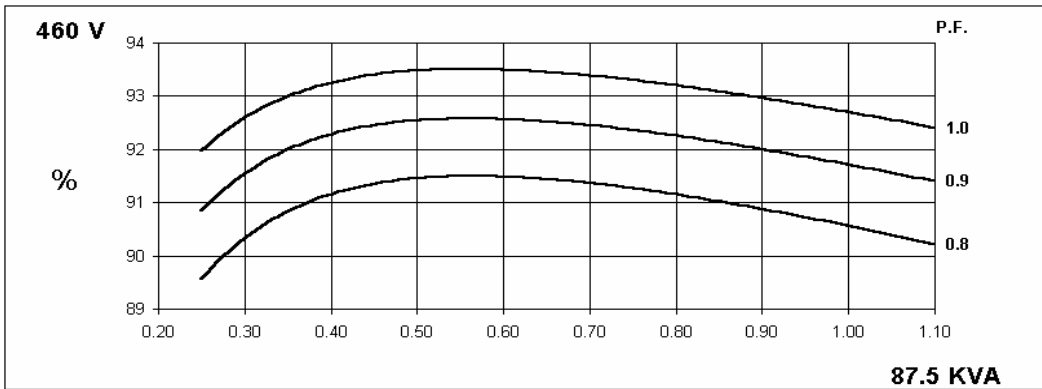
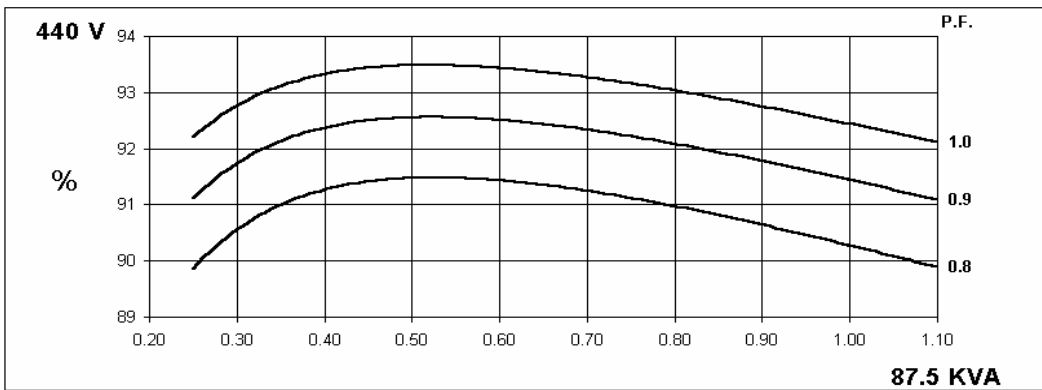
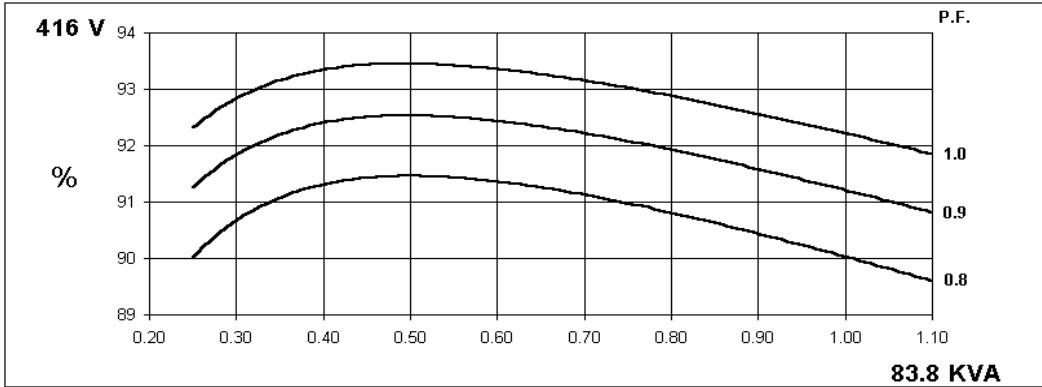

**Locked Rotor Motor Starting Curve**

**50  
Hz**

**MX**

**SX**

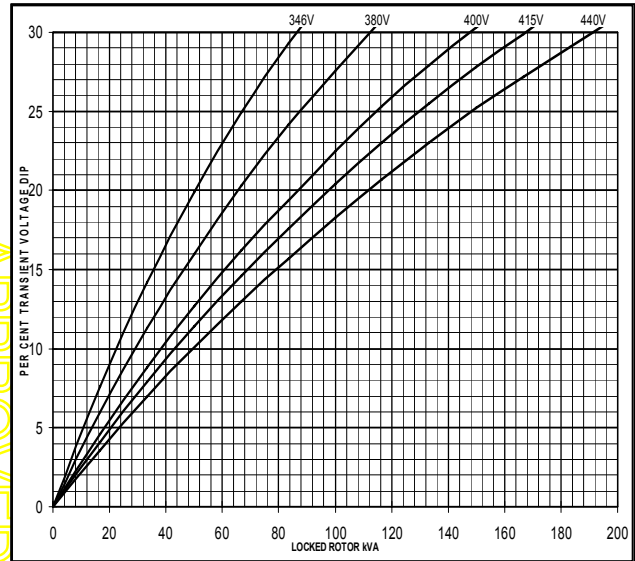
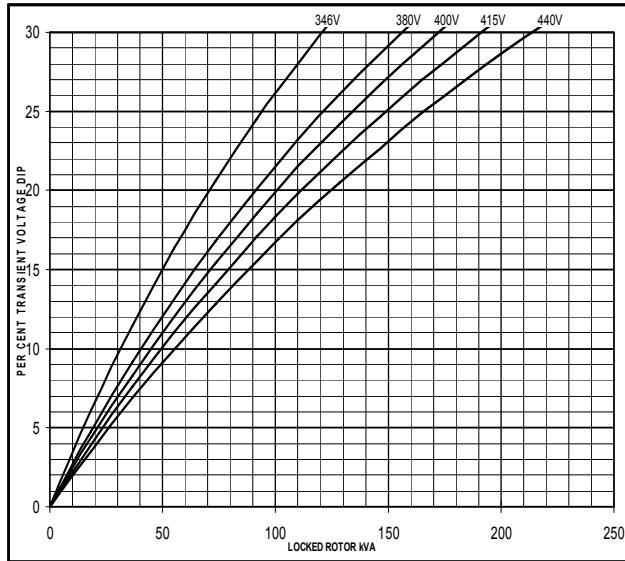

**60  
Hz**

**MX**

**SX**

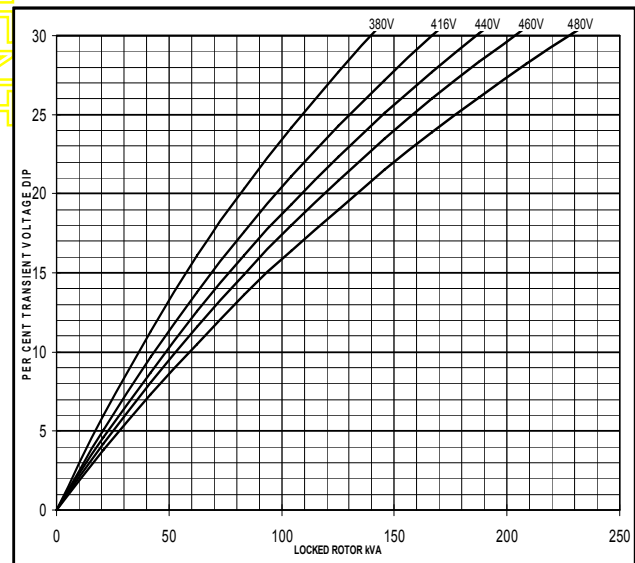
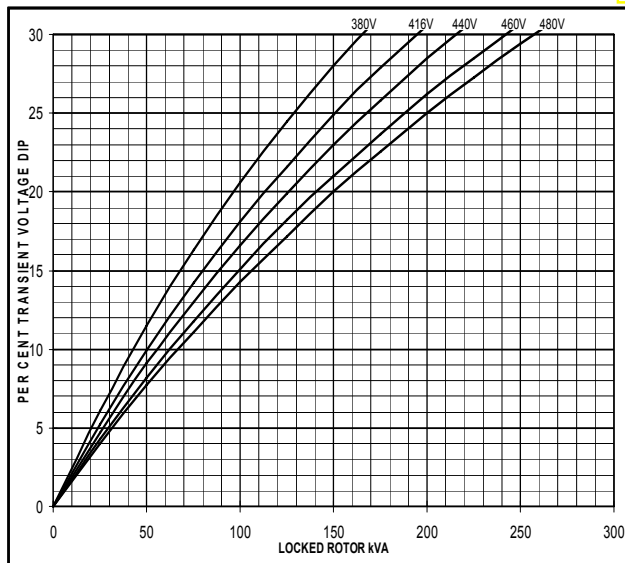

Three-phase Short Circuit Decrement Curve. No-load Excitation at Rated Speed  
Based on star (wye) connection.

**50  
Hz**

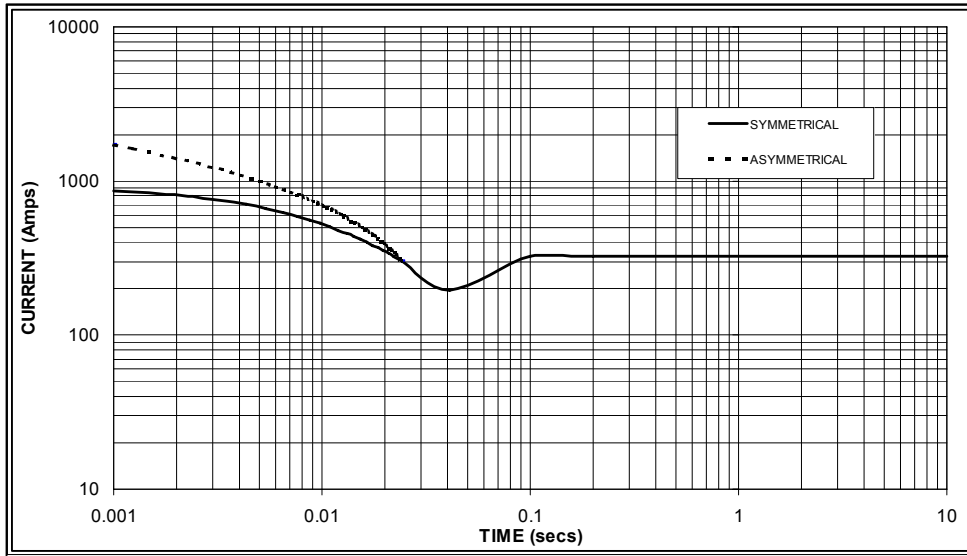

Sustained Short Circuit = 325 Amps



**60  
Hz**

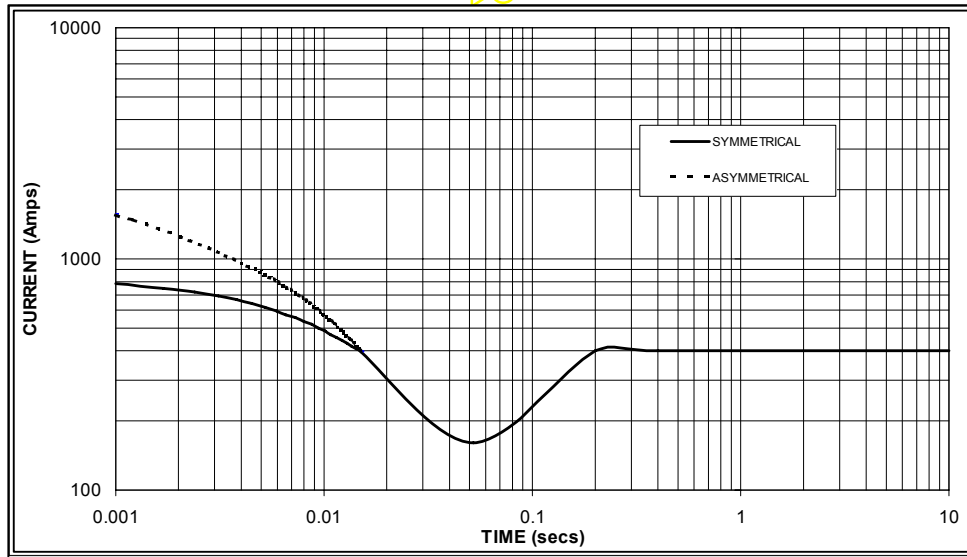

Sustained Short Circuit = 400 Amps

**Note 1**

The following multiplication factors should be used to adjust the values from curve between time 0.001 seconds and the minimum current point in respect of nominal operating voltage :

50Hz		60Hz	
Voltage	Factor	Voltage	Factor
380v	X 1.00	416v	X 1.00
400v	X 1.07	440v	X 1.06
415v	X 1.12	460v	X 1.12
440v	X 1.18	480v	X 1.17

The sustained current value is constant irrespective of voltage level

**Note 2**

The following multiplication factor should be used to convert the values calculated in accordance with NOTE 1 to those applicable to the various types of short circuit :

	3-phase	2-phase L-L	1-phase L-N
Instantaneous	x 1.00	x 0.87	x 1.30
Minimum	x 1.00	x 1.80	x 3.20
Sustained	x 1.00	x 1.50	x 2.50
Max. sustained duration	10 sec.	5 sec.	2 sec.

All other times are unchanged

**Note 3**

Curves are drawn for Star (Wye) connected machines. For other connection the following multipliers should be applied to current values as shown :

Parallel Star = Curve current value X 2

Series Delta = Curve current value X 1.732

# UCI224F

**STAMFORD**

## Winding 311 / 0.8 Power Factor

### RATINGS

Class - Temp Rise		Cont. F - 105/40°C				Cont. H - 125/40°C				Standby - 150/40°C				Standby - 163/27°C			
<b>50 Hz</b>	Series Star (V)	380	400	415	440	380	400	415	440	380	400	415	440	380	400	415	440
	Parallel Star (V)	190	200	208	220	190	200	208	220	190	200	208	220	190	200	208	220
	Series Delta (V)	220	230	240	254	220	230	240	254	220	230	240	254	220	230	240	254
	kVA	65.0	65.0	65.0	48.7	72.5	72.5	72.5	55.0	77.0	77.0	77.0	58.0	80.0	80.0	80.0	60.5
	kW	52.0	52.0	52.0	39.0	58.0	58.0	58.0	44.0	61.6	61.6	61.6	46.4	64.0	64.0	64.0	48.4
	Efficiency (%)	90.0	90.3	90.4	90.9	89.6	89.9	90.1	90.8	89.4	89.7	89.9	90.8	89.2	89.6	89.8	90.7
	kW Input	57.8	57.6	57.5	42.9	64.7	64.5	64.4	48.5	68.9	68.7	68.5	51.1	71.7	71.4	71.3	53.4

<b>60 Hz</b>	Series Star (V)	416	440	460	480	416	440	460	480	416	440	460	480	416	440	460	480
	Parallel Star (V)	208	220	230	240	208	220	230	240	208	220	230	240	208	220	230	240
	Delta (V)	240	254	266	277	240	254	266	277	240	254	266	277	240	254	266	277
	kVA	75.0	78.1	78.1	82.5	83.8	87.5	87.5	93.8	88.8	92.5	92.5	100.0	91.9	95.0	95.0	102.5
	kW	60.0	62.5	62.5	66.0	67.0	70.0	70.0	75.0	71.0	74.0	74.0	80.0	73.5	76.0	76.0	82.0
	Efficiency (%)	90.5	90.7	90.9	91.0	90.0	90.3	90.6	90.6	89.8	90.1	90.4	90.4	89.6	89.9	90.3	90.3
	kW Input	66.3	68.9	68.7	72.5	74.5	77.5	77.3	82.8	79.1	82.1	81.9	88.5	82.1	84.5	84.2	90.8

### DIMENSIONS

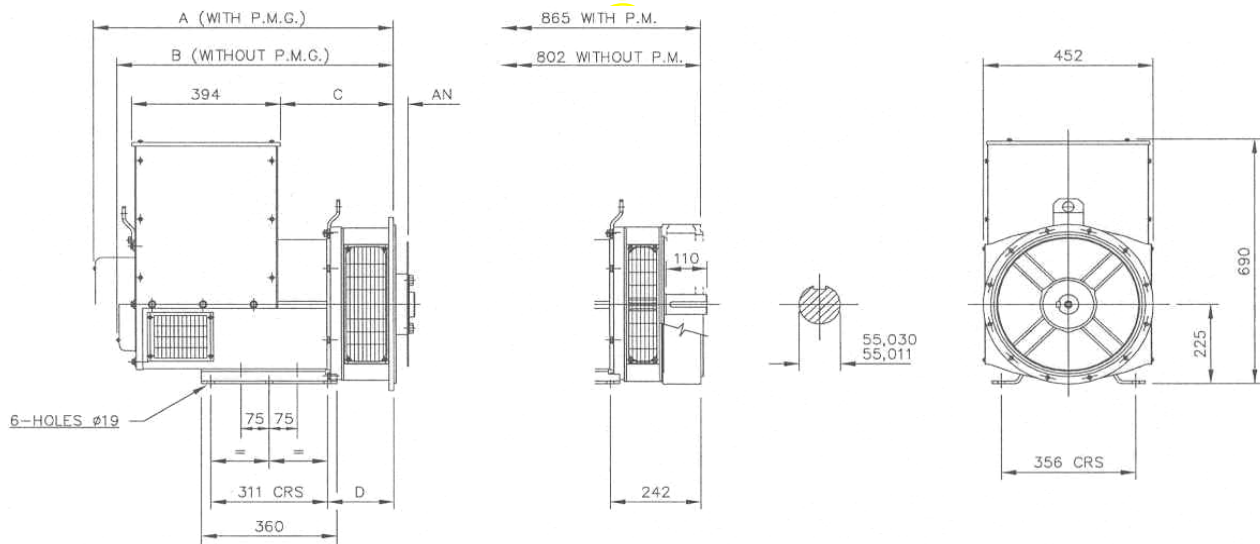

SINGLE BEARING MACHINES ONLY						
ADAPTOR	A	B	C	D	COUPLING DISCS	AN
SAE 1	814,3	751,3	314,3	191,3	SAE 8	61,90
SAE 2	800	737	300	177	SAE 10	53,98
SAE 3	800	737	300	177	SAE 11,5	39,68
SAE 4	800	737	300	177	SAE 14	25,40

APPROVED DOCUMENT

**STAMFORD**

Head Office Address:  
Barnack Road, Stamford  
Lincolnshire, PE9 2NB  
United Kingdom  
Tel: +44 (0) 1780 484000  
Fax: +44 (0) 1780 484100

[www.cumminsgeneratortechnologies.com](http://www.cumminsgeneratortechnologies.com)

Copyright 2010, Cummins Generator Technologies Ltd, All Rights Reserved  
Stamford and AvK are registered trade marks of Cummins Generator Technologies Ltd  
Cummins and the Cummins logo are registered trade marks of Cummins Inc.

# STAMFORD<sup>®</sup>

**UCI224F - Winding 17**

Technical Data Sheet

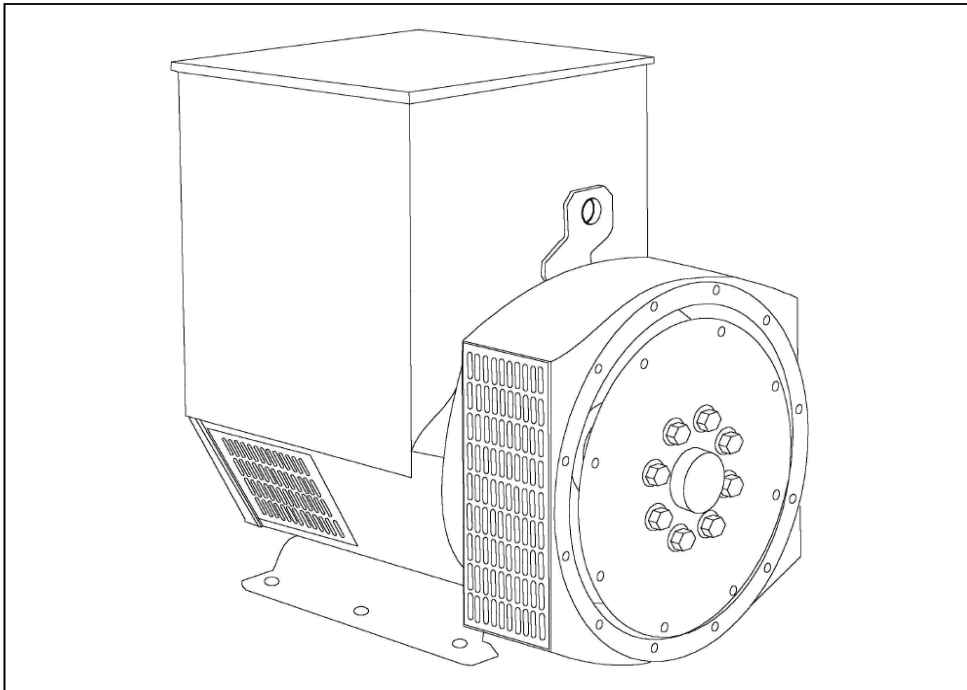



## SPECIFICATIONS &amp; OPTIONS

**STANDARDS**

Stamford industrial generators meet the requirements of BS EN 60034 and the relevant section of other international standards such as BS5000, VDE 0530, NEMA MG1-32, IEC34, CSA C22.2-100, AS1359.

Other standards and certifications can be considered on request.

**VOLTAGE REGULATORS****SX460 AVR - STANDARD**

With this self excited control system the main stator supplies power via the Automatic Voltage Regulator (AVR) to the exciter stator. The high efficiency semiconductors of the AVR ensure positive build-up from initial low levels of residual voltage.

The exciter rotor output is fed to the main rotor through a three phase full wave bridge rectifier. This rectifier is protected by a surge suppressor against surges caused, for example, by short circuit.

**AS440 AVR**

With this self-excited system the main stator provides power via the AVR to the exciter stator. The high efficiency semi-conductors of the AVR ensure positive build-up from initial low levels of residual voltage.

The exciter rotor output is fed to the main rotor through a three-phase full-wave bridge rectifier. The rectifier is protected by a surge suppressor against surges caused, for example, by short circuit or out-of-phase paralleling.

The AS440 will support a range of electronic accessories, including a 'droop' Current Transformer (CT) to permit parallel operation with other ac generators.

**MX341 AVR**

This sophisticated AVR is incorporated into the Stamford Permanent Magnet Generator (PMG) control system.

The PMG provides power via the AVR to the main exciter, giving a source of constant excitation power independent of generator output. The main exciter output is then fed to the main rotor, through a full wave bridge, protected by a surge suppressor. The AVR has in-built protection against sustained over-excitation, caused by internal or external faults. This de-excites the machine after a minimum of 5 seconds.

An engine relief load acceptance feature can enable full load to be applied to the generator in a single step.

If three-phase sensing is required with the PMG system the MX321 AVR must be used.

We recommend three-phase sensing for applications with greatly unbalanced or highly non-linear loads.

**MX321 AVR**

The most sophisticated of all our AVRs combines all the features of the MX341 with, additionally, three-phase rms sensing, for improved regulation and performance.

Over voltage protection is built-in and short circuit current level adjustments is an optional facility.

**WINDINGS & ELECTRICAL PERFORMANCE**

All generator stators are wound to 2/3 pitch. This eliminates triplen (3rd, 9th, 15th ...) harmonics on the voltage waveform and is found to be the optimum design for trouble-free supply of non-linear loads. The 2/3 pitch design avoids excessive neutral currents sometimes seen with higher winding pitches, when in parallel with the mains. A fully connected damper winding reduces oscillations during paralleling. This winding, with the 2/3 pitch and carefully selected pole and tooth designs, ensures very low waveform distortion.

**TERMINALS & TERMINAL BOX**

Standard generators are 3-phase reconnectable with 12 ends brought out to the terminals, which are mounted on a cover at the non-drive end of the generator. A sheet steel terminal box contains the AVR and provides ample space for the customers' wiring and gland arrangements. It has removable panels for easy access.

**SHAFT & KEYS**

All generator rotors are dynamically balanced to better than BS6861:Part 1 Grade 2.5 for minimum vibration in operation. Two bearing generators are balanced with a half key.

**INSULATION/IMPREGNATION**

The insulation system is class 'H'.

All wound components are impregnated with materials and processes designed specifically to provide the high build required for static windings and the high mechanical strength required for rotating components.

**QUALITY ASSURANCE**

Generators are manufactured using production procedures having a quality assurance level to BS EN ISO 9001.

The stated voltage regulation may not be maintained in the presence of certain radio transmitted signals. Any change in performance will fall within the limits of Criteria 'B' of EN 61000-6-2:2001. At no time will the steady-state voltage regulation exceed 2%.

**DE RATES**

All values tabulated on page 6 are subject to the following reductions

5% when air inlet filters are fitted.

3% for every 500 metres by which the operating altitude exceeds 1000 metres above mean sea level.

3% for every 5°C by which the operational ambient temperature exceeds 40°C.

Note: Requirement for operating in an ambient exceeding 60°C must be referred to the factory.

*NB Continuous development of our products entitles us to change specification details without notice, therefore they must not be regarded as binding.*

*Front cover drawing typical of product range.*

**UCI224F**  
**WINDING 17**

**STAMFORD**

CONTROL SYSTEM	SEPARATELY EXCITED BY P.M.G.		
A.V.R.	MX321	MX341	
VOLTAGE REGULATION	± 0.5 %	± 1.0 %	With 4% ENGINE GOVERNING
SUSTAINED SHORT CIRCUIT	REFER TO SHORT CIRCUIT DECREMENT CURVES (page 5)		
CONTROL SYSTEM	SELF EXCITED		
A.V.R.	SX460	AS440	
VOLTAGE REGULATION	± 1.0 %	± 1.0 %	With 4% ENGINE GOVERNING
SUSTAINED SHORT CIRCUIT	SERIES 4 CONTROL DOES NOT SUSTAIN A SHORT CIRCUIT CURRENT		
INSULATION SYSTEM	CLASS H		
PROTECTION	IP23		
RATED POWER FACTOR	0.8		
STATOR WINDING	DOUBLE LAYER CONCENTRIC		
WINDING PITCH	TWO THIRDS		
WINDING LEADS	12		
STATOR WDG. RESISTANCE	0.102 Ohms PER PHASE AT 22°C SERIES STAR CONNECTED		
ROTOR WDG. RESISTANCE	0.83 Ohms at 22°C		
EXCITER STATOR RESISTANCE	20 Ohms at 22°C		
EXCITER ROTOR RESISTANCE	0.078 Ohms PER PHASE AT 22°C		
R.F.I. SUPPRESSION	BS EN 61000-6-2 & BS EN 61000-6-4, VDE 0875G, VDE 0875N. refer to factory for others		
WAVEFORM DISTORTION	NO LOAD < 1.5% NON-DISTORTING BALANCED LINEAR LOAD < 5.0%		
MAXIMUM OVERSPEED	2250 Rev/Min		
BEARING DRIVE END	BALL. 6312-2RS (ISO)		
BEARING NON-DRIVE END	BALL. 6309-2RS (ISO)		
	1 BEARING	2 BEARING	
WEIGHT COMP. GENERATOR	337 kg	350 kg	
WEIGHT WOUND STATOR	120 kg	120 kg	
WEIGHT WOUND ROTOR	110.69 kg	102.32 kg	
WR <sup>2</sup> INERTIA	0.6071 kgm <sup>2</sup>	0.5754 kgm <sup>2</sup>	
SHIPPING WEIGHTS in a crate	360 kg	371 kg	
PACKING CRATE SIZE	105 x 57 x 96(cm)	105 x 57 x 96(cm)	
TELEPHONE INTERFERENCE	THF<2%	TIF<50	
COOLING AIR	0.281 m <sup>3</sup> /sec 595 cfm		
VOLTAGE SERIES STAR	600V		
VOLTAGE PARALLEL STAR	300V		
VOLTAGE SERIES DELTA	346V		
kVA BASE RATING FOR REACTANCE VALUES	94		
X <sub>d</sub> DIR. AXIS SYNCHRONOUS	1.86		
X' <sub>d</sub> DIR. AXIS TRANSIENT	0.15		
X'' <sub>d</sub> DIR. AXIS SUBTRANSIENT	0.10		
X <sub>q</sub> QUAD. AXIS REACTANCE	0.86		
X'' <sub>q</sub> QUAD. AXIS SUBTRANSIENT	0.10		
X <sub>L</sub> LEAKAGE REACTANCE	0.06		
X <sub>2</sub> NEGATIVE SEQUENCE	0.10		
X <sub>0</sub> ZERO SEQUENCE	0.07		
REACTANCES ARE SATURATED VALUES ARE PER UNIT AT RATING AND VOLTAGE INDICATED			
T' <sub>d</sub> TRANSIENT TIME CONST.	0.03s		
T'' <sub>d</sub> SUB-TRANSTIME CONST.	0.008s		
T' <sub>do</sub> O.C. FIELD TIME CONST.	0.75s		
T <sub>a</sub> ARMATURE TIME CONST.	0.0065s		
SHORT CIRCUIT RATIO	1/X <sub>d</sub>		

**UCI224F**

**STAMFORD**

Winding 17

**SX**

**Locked Rotor Motor Starting Curves**

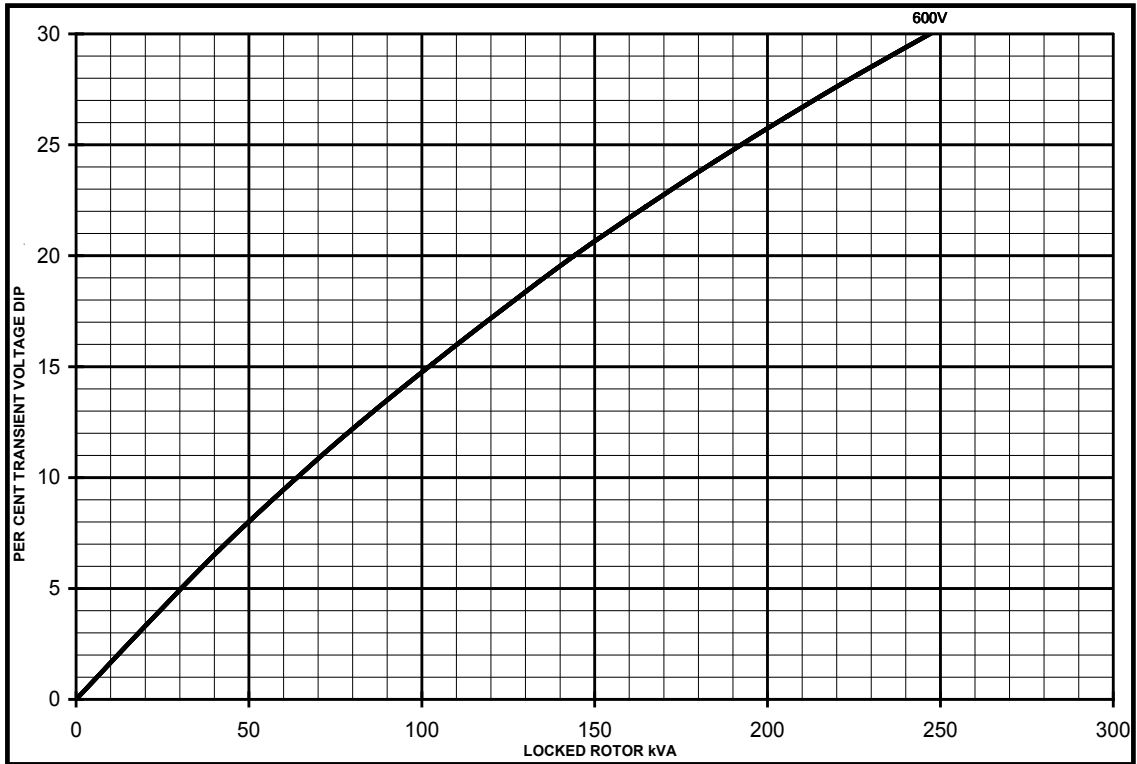

**MX**

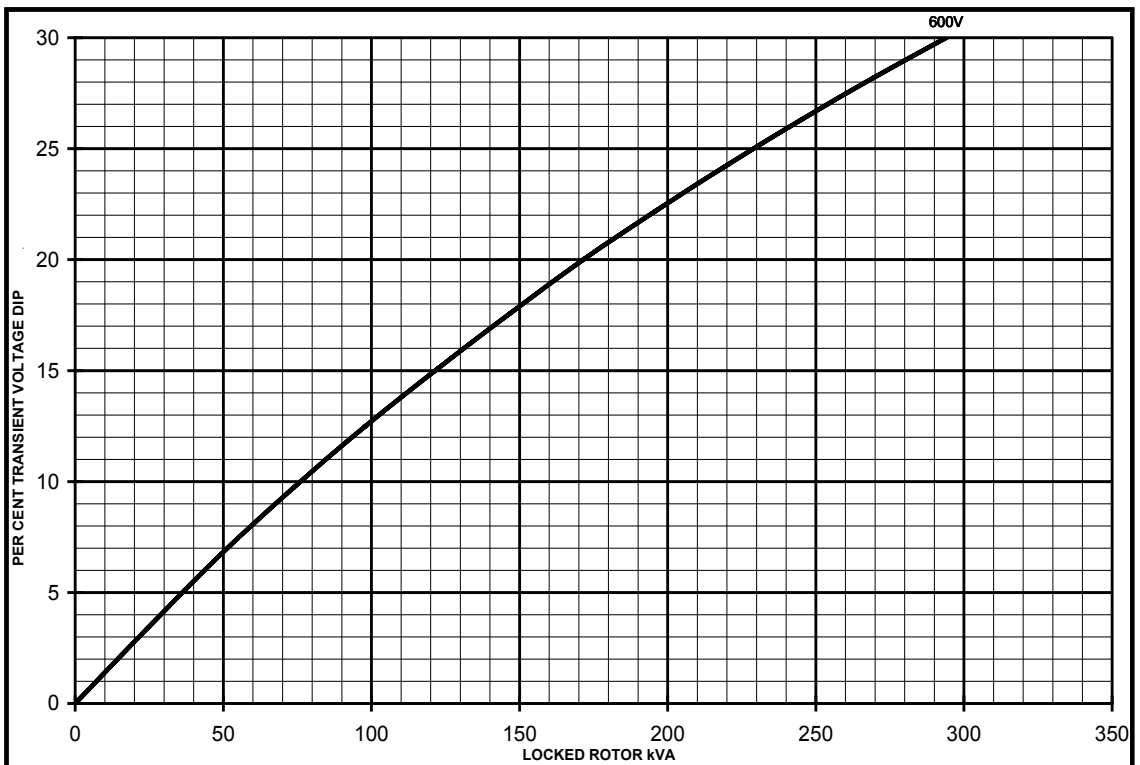

**UCI224F**  
Winding 17

**STAMFORD**

**THREE PHASE EFFICIENCY CURVES**

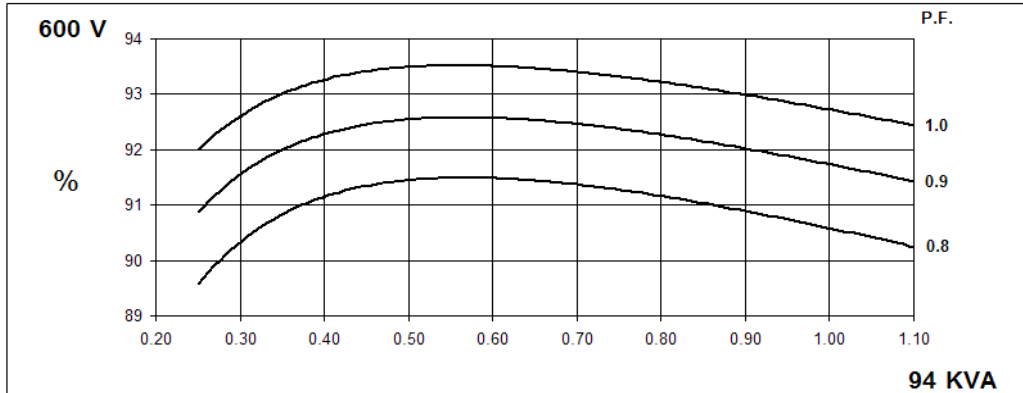

**Three-phase Short Circuit Decrement Curve. No-load Excitation at Rated Speed Based on star (wye) connection.**

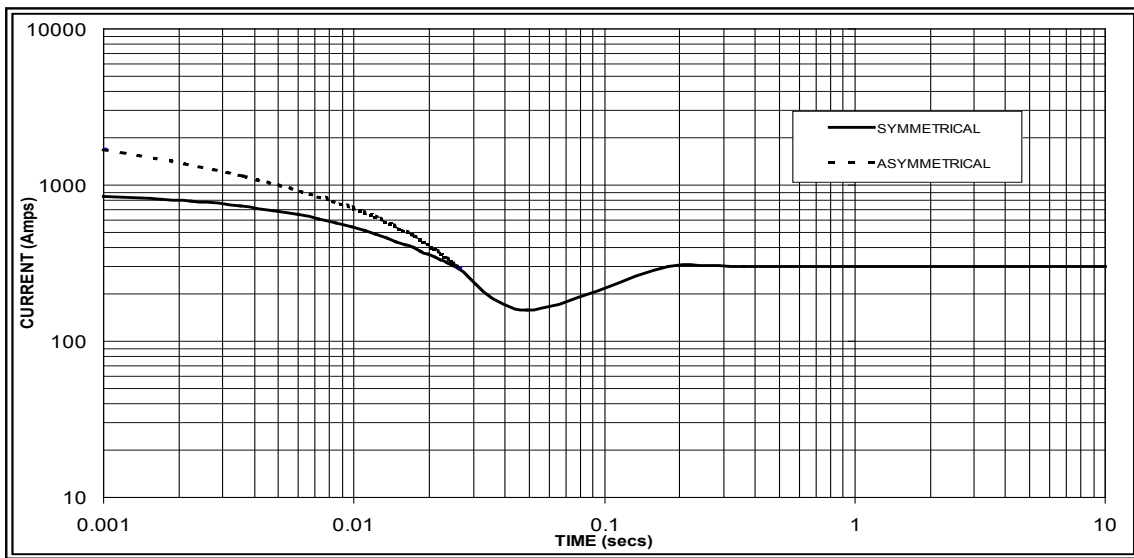

Sustained Short Circuit = 300 Amps

**Note**

The following multiplication factor should be used to convert the values from curve for the various types of short circuit :

	3-phase	2-phase L-L	1-phase L-N
Instantaneous	x 1.00	x 0.87	x 1.30
Minimum	x 1.00	x 1.80	x 3.20
Sustained	x 1.00	x 1.50	x 2.50
Max. sustained duration	10 sec.	5 sec.	2 sec.

All other times are unchanged

# UCI224F

**STAMFORD**

Winding 17 / 0.8 Power Factor

**60Hz**

## RATINGS

Class - Temp Rise	Cont. F - 105/40°C	Cont. H - 125/40°C	Standby - 150/40°C	Standby - 163/27°C
Series Star (V)	600	600	600	600
Parallel Star (V)	300	300	300	300
Series Delta (V)	346	346	346	346
kVA	82.5	94.0	98.8	102.5
kW	66.0	75.2	79.0	82.0
Efficiency (%)	91.0	90.6	90.4	90.3
kW Input	72.6	83.0	87.4	90.8

## DIMENSIONS

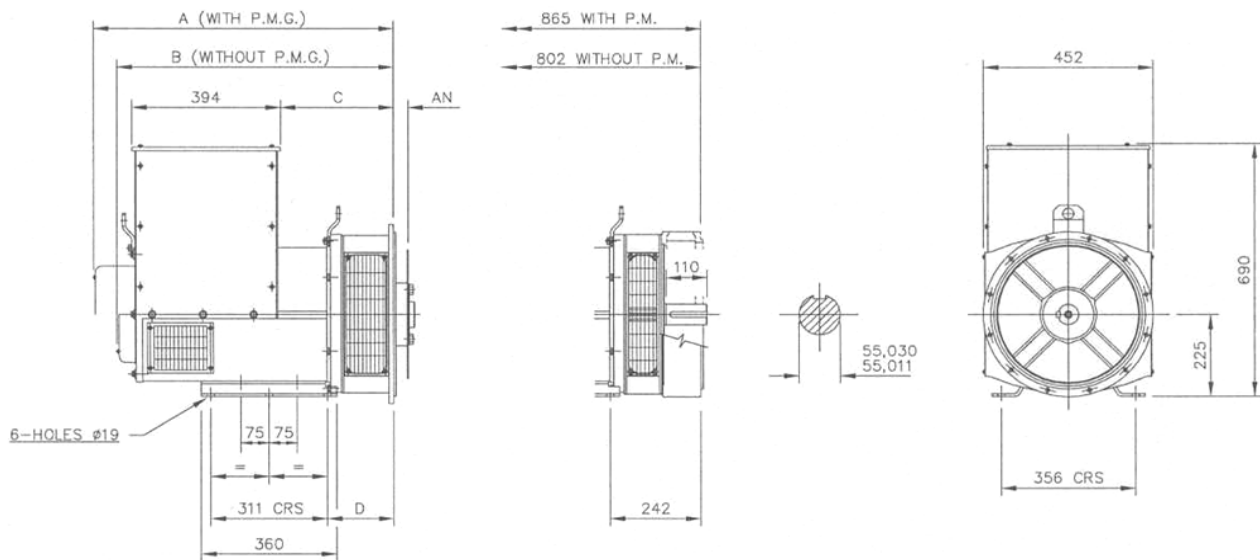

SINGLE BEARING MACHINES ONLY						
ADAPTOR	A	B	C	D	COUPLING DISCS	AN
SAE 1	814,3	751,3	314,3	191,3	SAE 8	61,90
SAE 2	800	737	300	177	SAE 10	53,98
SAE 3	800	737	300	177	SAE 11,5	39,68
SAE 4	800	737	300	177	SAE 14	25,40

## **STAMFORD**

Head Office Address:  
Barnack Road, Stamford  
Lincolnshire, PE9 2NB  
United Kingdom  
Tel: +44 (0) 1780 484000  
Fax: +44 (0) 1780 484100

[www.cumminsgeneratortechnologies.com](http://www.cumminsgeneratortechnologies.com)

Copyright 2010, Cummins Generator Technologies Ltd. All Rights Reserved  
Stamford and AvK are registered trade marks of Cummins Generator Technologies Ltd  
Cummins and the Cummins logo are registered trade marks of Cummins Inc.

# DSE7410/20

## AUTO START & AUTO MAINS FAILURE MODULES

### FEATURES



The DSE7410 is an Auto Start Control Module and the **DSE7420** is an Auto Mains (Utility) Failure Control Module suitable for a wide variety of single, diesel or gas, gen-set applications.

A sophisticated module monitoring an extensive number of engine parameters, the DSE74xx will announce warnings, shutdown and engine status information on the back-lit LCD screen, illuminated LED, remote PC, audible alarm and via SMS text alerts. The module includes RS232, RS485 & Ethernet ports as well as dedicated terminals for system expansion.

The DSE7400 Series modules are compatible with electronic (CAN) and non-electronic (magnetic pick-up/alternator sensing) engines and offer a comprehensive number of flexible inputs, outputs and extensive engine protections so the system can be easily adapted to meet the most demanding industry paralleling requirements.

The modules can be easily configured using the DSE Configuration Suite Software. Selected front panel editing is also available.

### ENVIRONMENTAL TESTING STANDARDS

#### ELECTRO-MAGNETIC COMPATIBILITY

BS EN 61000-6-2  
EMC Generic Immunity Standard for the Industrial Environment  
BS EN 61000-6-4  
EMC Generic Emission Standard for the Industrial Environment

#### ELECTRICAL SAFETY

BS EN 60950  
Safety of Information Technology Equipment, including Electrical Business Equipment

#### TEMPERATURE

BS EN 60068-2-1  
Ab/Ae Cold Test -30 °C  
BS EN 60068-2-2  
Bb/Be Dry Heat +70 °C

#### VIBRATION

BS EN 60068-2-6  
Ten sweeps in each of three major axes  
5 Hz to 8 Hz @ +/-7.5 mm,  
8 Hz to 500 Hz @ 2 gn

#### HUMIDITY

BS EN 60068-2-30  
Db Damp Heat Cyclic 20/55 °C @ 95% RH 48 Hours  
BS EN 60068-2-78  
Cab Damp Heat Static 40 °C @ 93% RH 48 Hours

#### SHOCK

BS EN 60068-2-27  
Three shocks in each of three major axes  
15 gn in 11 ms

#### DEGREES OF PROTECTION PROVIDED BY ENCLOSURES

BS EN 60529  
IP65 - Front of module when installed into the control panel with the supplied sealing gasket.

## COMPREHENSIVE FEATURE LIST TO SUIT A WIDE VARIETY OF GEN-SET APPLICATIONS

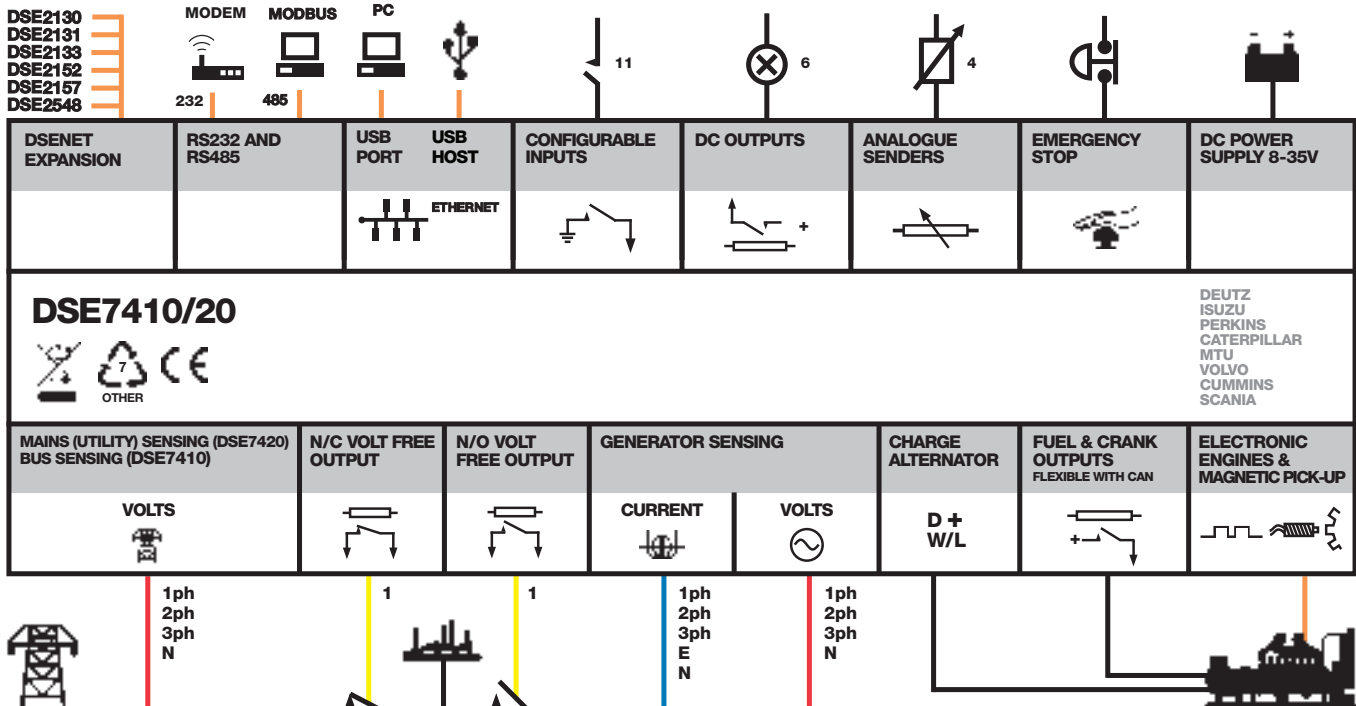

# DSE7410/20

## AUTO START & AUTO MAINS FAILURE MODULES

### FEATURES



### DSE7420

DSE7410



### KEY FEATURES

- Configurable inputs (11)
- Configurable outputs (8)
- Voltage measurement
- Mains (utility) failure detection
- Dedicated load test button
- kW overload alarms
- Comprehensive electrical protection
- RS232, RS485 & Ethernet remote communications
- Modbus RTU/TCP
- PLC functionality
- Multi event exercise timer
- Back-lit LCD 4-line text display
- Multiple display languages
- Automatic start/Manual start
- Audible alarm
- Fixed and flexible LED indicators
- Event log (250)
- Engine protection
- Fault condition notification to a designated PC
- Front panel mounting
- Protected front panel programming
- Configurable alarms and timers
- Configurable start and stop timers

- Five key menu navigation
- Front panel editing with PIN protection
- 3 configurable maintenance alarms
- CAN and magnetic pick-up/Alt. sensing
- Fuel usage monitor and low fuel alarms
- Charge alternator failure alarm
- Manual speed control (on compatible CAN engines)
- Manual fuel pump control
- "Protections disabled" feature
- Reverse power protection
- Power monitoring (kW h, kV Ar, kV A h, kV Ar h)
- Load switching (load shedding and dummy load outputs)
- Automatic load transfer (DSE7420)
- Unbalanced load protection
- Independent earth fault trip
- Fully configurable via DSE Configuration Suite PC software
- Configurable display languages
- Remote SCADA monitoring via DSE Configuration Suite PC software

- Advanced SMS messaging (additional external modem required)
- Start & stop capability via SMS messaging
- Additional display screens to help with modem diagnostics
- DSENet® expansion
- Integral PLC editor

### KEY BENEFITS

- RS232, RS485 & Ethernet can be used at the same time
- DSENet® connection for system expansion
- PLC functionality
- Five step dummy load support
- Five step load shedding support
- High number of inputs and outputs
- Worldwide language support
- Direct USB connection to PC
- Ethernet monitoring
- USB host
- Data logging & trending

### RELATED MATERIALS

#### TITLE

DSE7410 Installation Instructions  
**DSE7420** Installation Instructions  
 DSE74xx Quick Start Guide  
 DSE74xx Operator Manual  
 DSE74xx PC Configuration Suite Manual

#### PART NO'S

053-085  
 053-088  
 057-162  
 057-161  
 057-160

### SPECIFICATION

#### DC SUPPLY

**CONTINUOUS VOLTAGE RATING**  
 8 V to 35 V Continuous

#### CRANKING DROPOUTS

Able to survive 0 V for 50 ms, providing supply was at least 10 V before dropout and supply recovers to 5 V. This is achieved without the need for internal batteries

#### MAXIMUM OPERATING CURRENT

260 mA at 12 V, 130 mA at 24 V

#### MAXIMUM STANDBY CURRENT

120 mA at 12 V, 65 mA at 24 V

#### CHARGE FAIL/EXCITATION RANGE

0 V to 35 V

#### OUTPUTS

##### OUTPUT A (FUEL)

15 A DC at supply voltage

##### OUTPUT B (START)

15 A DC at supply voltage

##### OUTPUTS C & D

8 A AC at 250 V AC (Volt free)

##### AUXILIARY OUTPUTS E, F, G, H, I & J

2 A DC at supply voltage

#### GENERATOR

**VOLTAGE RANGE**  
 15 V to 333 V AC (L-N)

**FREQUENCY RANGE**  
 3.5 Hz to 75 Hz

**MAINS (UTILITY) (DSE7420)**  
**VOLTAGE RANGE**  
 15 V to 333 V AC (L-N)

**FREQUENCY RANGE**  
 3.5 Hz to 75 Hz

**BUS (DSE7410)**  
**VOLTAGE RANGE**  
 15 V to 333 V AC (L-N)

**FREQUENCY RANGE**  
 3.5 Hz to 75 Hz

**MAGNETIC PICK UP**  
**VOLTAGE RANGE**  
 +/- 0.5 V to 70 V

**FREQUENCY RANGE**  
 10,000 Hz (max)

**DIMENSIONS**  
**OVERALL**  
 240 mm x 172 mm x 57 mm  
 9.4" x 6.8" x 2.2"

**PANEL CUTOUT**  
 220 mm x 160 mm  
 8.7" x 6.3"

**MAXIMUM PANEL THICKNESS**  
 8 mm  
 0.3"

**STORAGE TEMPERATURE RANGE**  
 -40°C to +85°C

### DEEP SEA ELECTRONICS PLC UK

Highfield House, Hunmanby Industrial Estate, Hunmanby YO14 0PH  
**TELEPHONE** +44 (0) 1723 890099 **FACSIMILE** +44 (0) 1723 893303  
**EMAIL** sales@deepseapl.com **WEBSITE** www.deepseapl.com

### DEEP SEA ELECTRONICS INC USA

3230 Williams Avenue, Rockford, IL 61101-2668 USA  
**TELEPHONE** +1 (815) 316 8706 **FACSIMILE** +1 (815) 316 8708  
**EMAIL** sales@deepseausa.com **WEBSITE** www.deepseausa.com



**Molded Case Circuit Breakers**  
**Power Defense™ UL Global Series**  
**Part Number: PDG23G0080TFFJNNNNNN**



Datasheet creation date: 02/12/2019

**PRODUCT VIEW** *(Use Mouse to Rotate and Zoom)*

Eaton's Power Defense™ molded case circuit breakers, a globally rated platform designed to help keep your power system safe with latest protection technology. Engineered for the future: IoT and Industry 4.0 features such as built-in communications, advanced energy metering, and algorithms that signal breaker maintenance; zone selective interlock technology that clears faults quickly and locally; ArcFlash reduction options that help protect your people, and not to mention Eaton's best-in-class support and service.

**Tech Data for Configured Product**

<b>Power Defense Catalog Number</b>	PDG23G0080TFFJNNNNNN
<b>Frame Size</b>	Frame 2
<b>Poles</b>	3 Pole
<b>Voltage</b>	480V AC
<b>Interruption or Breaking Capacity ( Icu/Ics)</b>	35kA
<b>Continuous Current Rating (In)</b>	80A
<b>Trip Unit Type</b>	TM Trip Unit
<b>Trip Unit Options 1</b>	Fixed
<b>Trip Unit Options 2</b>	Fixed
<b>Indicating Accessories</b>	None
<b>Indicating Accessories Terminal</b>	None
<b>Tripping Accessories</b>	None
<b>Tripping Accessory Terminal</b>	None
<b>Tripping Accessory Voltage</b>	None
<b>Line Type Description</b>	Option 1 - Standard Terminal
<b>Line Conductor Options</b>	(1) 14 - 1/0
<b>Line Terminal Type</b>	Steel Pressure/Box
<b>Load Type Description</b>	Option 1 - Standard Terminal
<b>Load Conductor Options</b>	(1) 14 - 1/0
<b>Load Terminal Type</b>	Steel Pressure/Box
<b>Special Options - Type of Modification</b>	None
<b>Details</b>	None
<b>Additional Description</b>	None

**Molded Case Circuit Breakers**  
**Power Defense™ UL Global Series**  
**Part Number: PDG23G0080TFFJNNNNN**

**Technical drawings**

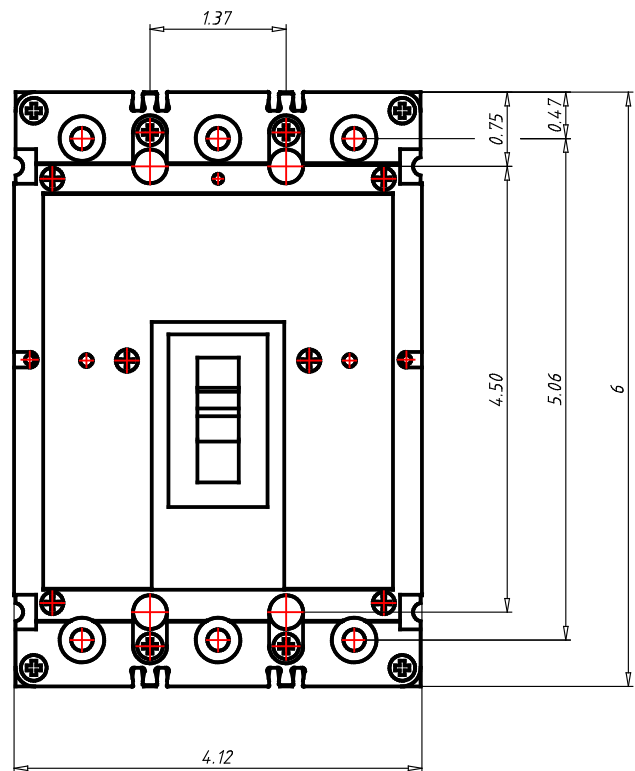
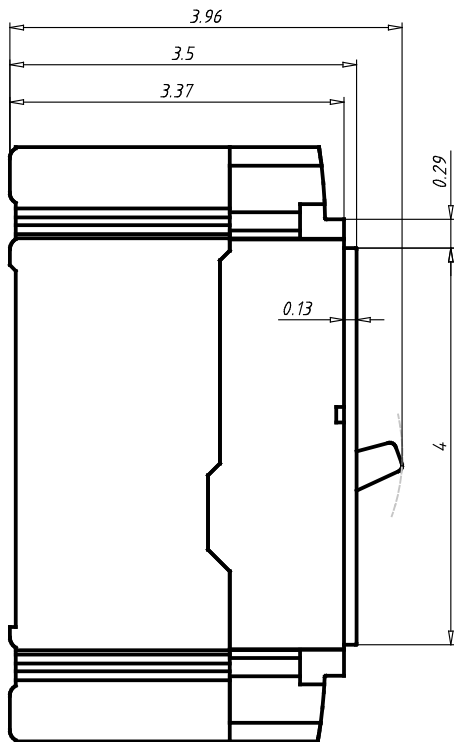

**Molded Case Circuit Breakers**  
**Power Defense™ UL Global Series**  
**Part Number: PDG23G0080TFFJNNNNNN**

**General Technical Data**

Frame Rating (In)	80A
Reference Standard	UL489, CSA 22.2, IEC 60947-2 & GB
Number of poles	3
Neutral rating	-
Interruption Rating Designator	F / G / K / M / N / P
UL Interruption Rating to UL 489 (240Vac)	35 / 65 / 85 / 100 / 150 / 200kA
UL Interruption Rating to UL 489 (480Vac)	25 / 35 / 50 / 65(a) / 85 / 100kA
UL Interruption Rating to UL 489 (600Vac)	14 / 18 / 22 / 25 / 30 / 35kA
UL Interruption Rating to UL 489 (125/250Vdc)	10 / 10 / 10 / 22 / 22 / 22kA
UL Current Limiting	N / N / Y / Y / Y / Y
Rated breaking capacity to IEC 60947-2 (220-240 Vac Icu)	35 / 55 / 85 / 100 / 150 / 200kA
Rated breaking capacity to IEC 60947-2 (220-240 Vac Ics)	35 / 55 / 85 / 100 / 100 / 150kA
Rated breaking capacity to IEC 60947-2 (380-415 Vac Icu)	25 / 36 / 50 / 70 / 70 / 100kA
Rated breaking capacity to IEC 60947-2 (380-415 Vac Ics)	25 / 36 / 50 / 53 / 70 / 70kA
Rated breaking capacity to IEC 60947-2 (440 Vac Icu)	25 / 30 / 35 / 50 / 70 / 100kA
Rated breaking capacity to IEC 60947-2 (440 Vac Ics)	20 / 22.5 / 35 / 40 / 50 / 65kA
Rated breaking capacity to IEC 60947-2 (525 Vac Icu)	
Rated breaking capacity to IEC 60947-2 (525 Vac Ics)	15 / 15 / 15 / 15 / 15 / 18kA
Rated breaking capacity to IEC 60947-2 (690 Vac Icu)	- / 8 / 10 / 10 / 10 / 10kA
Rated breaking capacity to IEC 60947-2 (690 Vac Ics)	- / 4 / 5 / 5 / 5 / 5kA
Rated breaking capacity to IEC 60947-2 (125V DC Icu)	10 / 10 / 10 / 22 / 22 / 22kA
Rated breaking capacity to IEC 60947-2 (250V DC 2P in series Ics)	10 / 10 / 10 / 22 / 22 / 22kA
Frequency	50/60Hz
Trip Unit Type	TM Trip Unit
Continuous Current Range	Fixed
100% UL489 Rated	
Instantaneous/Short Circuit Range	Fixed
Magnetic/Instantaneous Override	700A
Dimensions H x W x D (inches)	6 x 4.12 x 3.50
Pole to pole distance inches	1,375
Approx Weight lbs	4
RoHS Compliance	Yes
UL File Number	E7819
Ambient Temp Calibration	
Derating at 50C	
Derating at 60C	95%
Derating at 70C	90%

1. 480Vac corresponds to 277Vac for 1P
2. 600Vac corresponds to 347Vac for 1P

**Molded Case Circuit Breakers**  
**Power Defense™ UL Global Series**  
**Part Number: PDG23G0100TFFJNNNNNN**



Datasheet creation date: 02/12/2019

**PRODUCT VIEW** *(Use Mouse to Rotate and Zoom)*

Eaton's Power Defense™ molded case circuit breakers, a globally rated platform designed to help keep your power system safe with latest protection technology. Engineered for the future: IoT and Industry 4.0 features such as built-in communications, advanced energy metering, and algorithms that signal breaker maintenance; zone selective interlock technology that clears faults quickly and locally; ArcFlash reduction options that help protect your people, and not to mention Eaton's best-in-class support and service.

**Tech Data for Configured Product**

<b>Power Defense Catalog Number</b>	PDG23G0100TFFJNNNNNN
<b>Frame Size</b>	Frame 2
<b>Poles</b>	3 Pole
<b>Voltage</b>	480V AC
<b>Interruption or Breaking Capacity ( Icu/Ics)</b>	35kA
<b>Continuous Current Rating (In)</b>	100A
<b>Trip Unit Type</b>	TM Trip Unit
<b>Trip Unit Options 1</b>	Fixed
<b>Trip Unit Options 2</b>	Fixed
<b>Indicating Accessories</b>	None
<b>Indicating Accessories Terminal</b>	None
<b>Tripping Accessories</b>	None
<b>Tripping Accessory Terminal</b>	None
<b>Tripping Accessory Voltage</b>	None
<b>Line Type Description</b>	Option 1 - Standard Terminal
<b>Line Conductor Options</b>	(1) 14 - 1/0
<b>Line Terminal Type</b>	Steel Pressure/Box
<b>Load Type Description</b>	Option 1 - Standard Terminal
<b>Load Conductor Options</b>	(1) 14 - 1/0
<b>Load Terminal Type</b>	Steel Pressure/Box
<b>Special Options - Type of Modification</b>	None
<b>Details</b>	None
<b>Additional Description</b>	None

**Molded Case Circuit Breakers**  
**Power Defense™ UL Global Series**  
**Part Number: PDG23G0100TFFJNNNNN**

**Technical drawings**

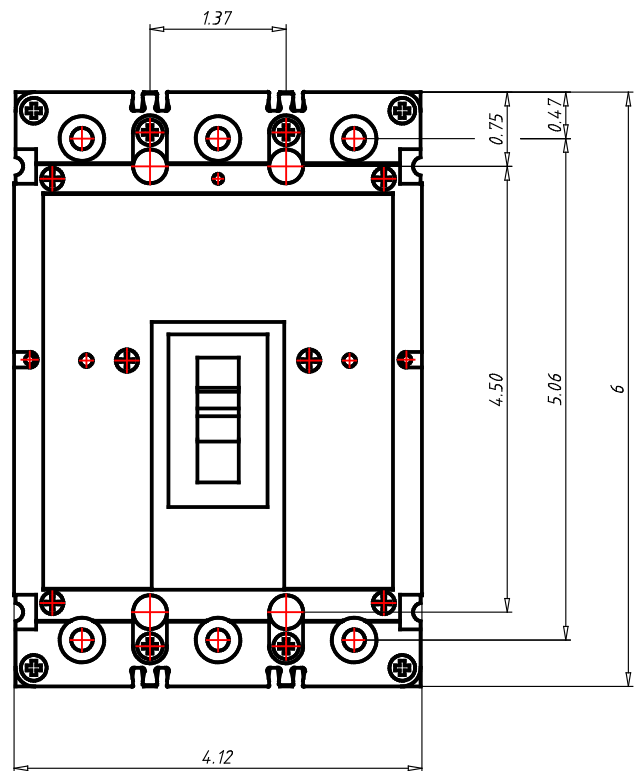
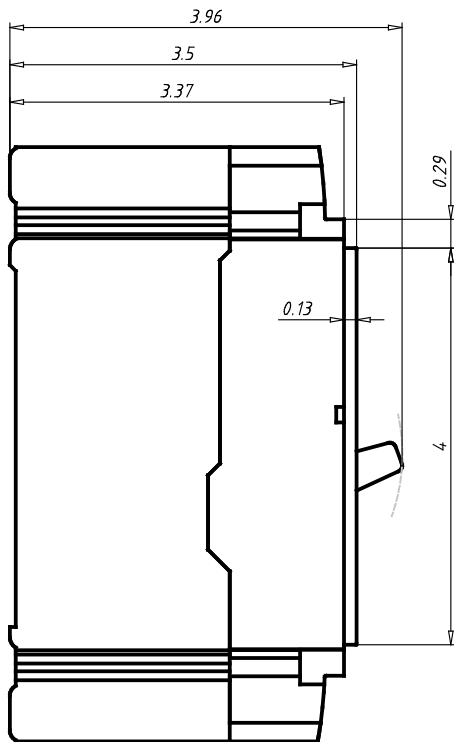

**Molded Case Circuit Breakers**  
**Power Defense™ UL Global Series**  
**Part Number: PDG23G0100TFFJNNNNNN**



Datasheet creation date: 02/12/2019

**General Technical Data**

Frame Rating (In)	100A
Reference Standard	UL489, CSA 22.2, IEC 60947-2 & GB
Number of poles	3
Neutral rating	-
Interruption Rating Designator	F / G / K / M / N / P
UL Interruption Rating to UL 489 (240Vac)	35 / 65 / 85 / 100 / 150 / 200kA
UL Interruption Rating to UL 489 (480Vac)	25 / 35 / 50 / 65(a) / 85 / 100kA
UL Interruption Rating to UL 489 (600Vac)	14 / 18 / 22 / 25 / 30 / 35kA
UL Interruption Rating to UL 489 (125/250Vdc)	10 / 10 / 10 / 22 / 22 / 22kA
UL Current Limiting	N / N / Y / Y / Y / Y
Rated breaking capacity to IEC 60947-2 (220-240 Vac Icu)	35 / 55 / 85 / 100 / 150 / 200kA
Rated breaking capacity to IEC 60947-2 (220-240 Vac Ics)	35 / 55 / 85 / 100 / 100 / 150kA
Rated breaking capacity to IEC 60947-2 (380-415 Vac Icu)	25 / 36 / 50 / 70 / 70 / 100kA
Rated breaking capacity to IEC 60947-2 (380-415 Vac Ics)	25 / 36 / 50 / 53 / 70 / 70kA
Rated breaking capacity to IEC 60947-2 (440 Vac Icu)	25 / 30 / 35 / 50 / 70 / 100kA
Rated breaking capacity to IEC 60947-2 (440 Vac Ics)	20 / 22.5 / 35 / 40 / 50 / 65kA
Rated breaking capacity to IEC 60947-2 (525 Vac Icu)	
Rated breaking capacity to IEC 60947-2 (525 Vac Ics)	15 / 15 / 15 / 15 / 15 / 18kA
Rated breaking capacity to IEC 60947-2 (690 Vac Icu)	- / 8 / 10 / 10 / 10 / 10kA
Rated breaking capacity to IEC 60947-2 (690 Vac Ics)	- / 4 / 5 / 5 / 5 / 5kA
Rated breaking capacity to IEC 60947-2 (125V DC Icu)	10 / 10 / 10 / 22 / 22 / 22kA
Rated breaking capacity to IEC 60947-2 (250V DC 2P in series Ics)	10 / 10 / 10 / 22 / 22 / 22kA
Frequency	50/60Hz
Trip Unit Type	TM Trip Unit
Continuous Current Range	Fixed
100% UL489 Rated	
Instantaneous/Short Circuit Range	Fixed
Magnetic/Instantaneous Override	700A
Dimensions H x W x D (inches)	6 x 4.12 x 3.50
Pole to pole distance inches	1,375
Approx Weight lbs	4
RoHS Compliance	Yes
UL File Number	E7819
Ambient Temp Calibration	
Derating at 50C	
Derating at 60C	95%
Derating at 70C	90%

1. 480Vac corresponds to 277Vac for 1P
2. 600Vac corresponds to 347Vac for 1P

**Molded Case Circuit Breakers**  
**Power Defense™ UL Global Series**  
**Part Number: PDG23G0200TFFJNNNNNN**



Datasheet creation date: 13/11/2019

**PRODUCT VIEW** *(Use Mouse to Rotate and Zoom)*

Eaton's Power Defense™ molded case circuit breakers, a globally rated platform designed to help keep your power system safe with latest protection technology. Engineered for the future: IoT and Industry 4.0 features such as built-in communications, advanced energy metering, and algorithms that signal breaker maintenance; zone selective interlock technology that clears faults quickly and locally; ArcFlash reduction options that help protect your people, and not to mention Eaton's best-in-class support and service.

**Tech Data for Configured Product**

<b>Power Defense Catalog Number</b>	PDG23G0200TFFJNNNNNN
<b>Frame Size</b>	Frame 2
<b>Poles</b>	3 Pole
<b>Voltage</b>	480V AC
<b>Interruption or Breaking Capacity ( Icu/Ics)</b>	35kA
<b>Continuous Current Rating (In)</b>	200A
<b>Trip Unit Type</b>	TM Trip Unit
<b>Trip Unit Options 1</b>	Fixed
<b>Trip Unit Options 2</b>	Fixed
<b>Indicating Accessories</b>	None
<b>Indicating Accessories Terminal</b>	None
<b>Tripping Accessories</b>	None
<b>Tripping Accessory Terminal</b>	None
<b>Tripping Accessory Voltage</b>	None
<b>Line Type Description</b>	Option 1 - Standard Terminal
<b>Line Conductor Options</b>	(1) 4 - 4/0
<b>Line Terminal Type</b>	Aluminum
<b>Load Type Description</b>	Option 1 - Standard Terminal
<b>Load Conductor Options</b>	(1) 4 - 4/0
<b>Load Terminal Type</b>	Aluminum
<b>Special Options - Type of Modification</b>	None
<b>Details</b>	None
<b>Additional Description</b>	None

**Molded Case Circuit Breakers**  
**Power Defense™ UL Global Series**  
**Part Number: PDG23G0200TFFJNNNNN**

**Technical drawings**

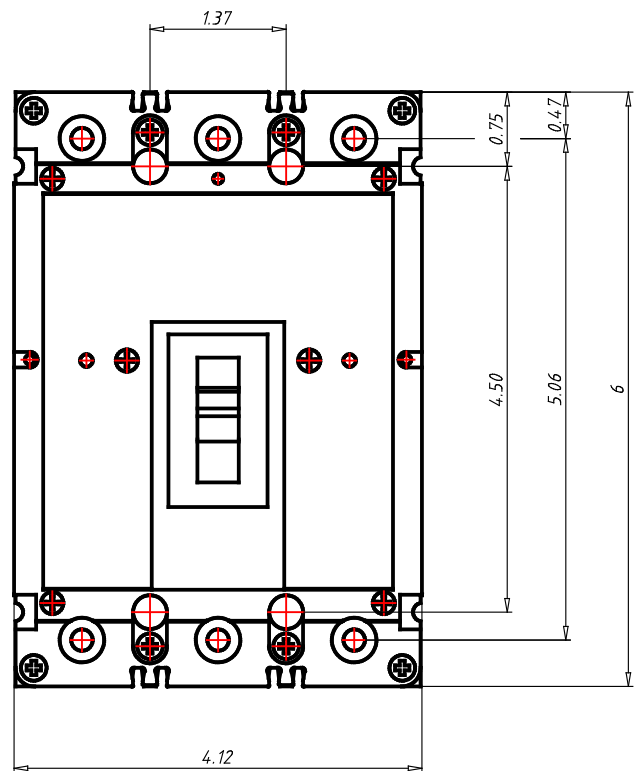
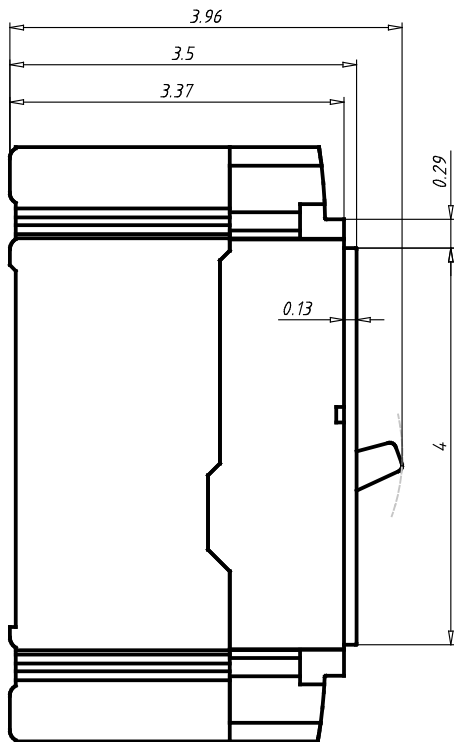



**Molded Case Circuit Breakers**  
**Power Defense™ UL Global Series**  
**Part Number: PDG23G0200TFFJNNNNNN**

**General Technical Data**

Frame Rating (In)	200A
Reference Standard	UL489, CSA 22.2, IEC 60947-2 & GB
Number of poles	3
Neutral rating	-
Interruption Rating Designator	F / G / K / M / N / P
UL Interruption Rating to UL 489 (240Vac)	35 / 65 / 85 / 100 / 150 / 200kA
UL Interruption Rating to UL 489 (480Vac)	25 / 35 / 50 / 65(a) / 85 / 100kA
UL Interruption Rating to UL 489 (600Vac)	14 / 18 / 22 / 25 / 30 / 35kA
UL Interruption Rating to UL 489 (125/250Vdc)	10 / 10 / 10 / 22 / 22 / 22kA
UL Current Limiting	N / N / Y / Y / Y / Y
Rated breaking capacity to IEC 60947-2 (220-240 Vac Icu)	35 / 55 / 85 / 100 / 150 / 200kA
Rated breaking capacity to IEC 60947-2 (220-240 Vac Ics)	35 / 55 / 85 / 100 / 100 / 150kA
Rated breaking capacity to IEC 60947-2 (380-415 Vac Icu)	25 / 36 / 50 / 70 / 70 / 100kA
Rated breaking capacity to IEC 60947-2 (380-415 Vac Ics)	25 / 36 / 50 / 53 / 70 / 70kA
Rated breaking capacity to IEC 60947-2 (440 Vac Icu)	25 / 30 / 35 / 50 / 70 / 100kA
Rated breaking capacity to IEC 60947-2 (440 Vac Ics)	20 / 22.5 / 35 / 40 / 50 / 65kA
Rated breaking capacity to IEC 60947-2 (525 Vac Icu)	
Rated breaking capacity to IEC 60947-2 (525 Vac Ics)	15 / 15 / 15 / 15 / 15 / 18kA
Rated breaking capacity to IEC 60947-2 (690 Vac Icu)	- / 8 / 10 / 10 / 10 / 10kA
Rated breaking capacity to IEC 60947-2 (690 Vac Ics)	- / 4 / 5 / 5 / 5 / 5kA
Rated breaking capacity to IEC 60947-2 (125V DC Icu)	10 / 10 / 10 / 22 / 22 / 22kA
Rated breaking capacity to IEC 60947-2 (250V DC 2P in series Ics)	10 / 10 / 10 / 22 / 22 / 22kA
Frequency	50/60Hz
Trip Unit Type	TM Trip Unit
Continuous Current Range	Fixed
100% UL489 Rated	
Instantaneous/Short Circuit Range	Fixed
Magnetic/Instantaneous Override	2000A
Dimensions H x W x D (inches)	6 x 4.12 x 3.50
Pole to pole distance inches	1,375
Approx Weight lbs	4
RoHS Compliance	Yes
UL File Number	E7819
Ambient Temp Calibration	
Derating at 50C	
Derating at 60C	95%
Derating at 70C	90%

1. 480Vac corresponds to 277Vac for 1P
2. 600Vac corresponds to 347Vac for 1P

**Molded Case Circuit Breakers**  
**Power Defense™ UL Global Series**  
**Part Number: PDG33G0250B2NJNNNNNN**



Datasheet creation date: 02/12/2019

**PRODUCT VIEW** *(Use Mouse to Rotate and Zoom)*

Eaton's Power Defense™ molded case circuit breakers, a globally rated platform designed to help keep your power system safe with latest protection technology. Engineered for the future: IoT and Industry 4.0 features such as built-in communications, advanced energy metering, and algorithms that signal breaker maintenance; zone selective interlock technology that clears faults quickly and locally; ArcFlash reduction options that help protect your people, and not to mention Eaton's best-in-class support and service.

**Tech Data for Configured Product**

<b>Power Defense Catalog Number</b>	PDG33G0250B2NJNNNNNN
<b>Frame Size</b>	Frame 3
<b>Poles</b>	3 Pole
<b>Voltage</b>	480V AC
<b>Interruption or Breaking Capacity ( Icu/Ics)</b>	35kA
<b>Continuous Current Rating (In)</b>	250A
<b>Trip Unit Type</b>	PXR10
<b>Trip Unit Options 1</b>	LSI
<b>Trip Unit Options 2</b>	None
<b>Indicating Accessories</b>	None
<b>Indicating Accessories Terminal</b>	None
<b>Tripping Accessories</b>	None
<b>Tripping Accessory Terminal</b>	None
<b>Tripping Accessory Voltage</b>	None
<b>Line Type Description</b>	Option 1 - Standard Terminal
<b>Line Conductor Options</b>	(1) 250 - 500
<b>Line Terminal Type</b>	Aluminum
<b>Load Type Description</b>	Option 1 - Standard Terminal
<b>Load Conductor Options</b>	(1) 250 - 500
<b>Load Terminal Type</b>	Aluminum
<b>Special Options - Type of Modification</b>	None
<b>Details</b>	None
<b>Additional Description</b>	None

**Molded Case Circuit Breakers**  
**Power Defense™ UL Global Series**  
**Part Number: PDG33G0250B2NJNNNNNN**

**Technical drawings**

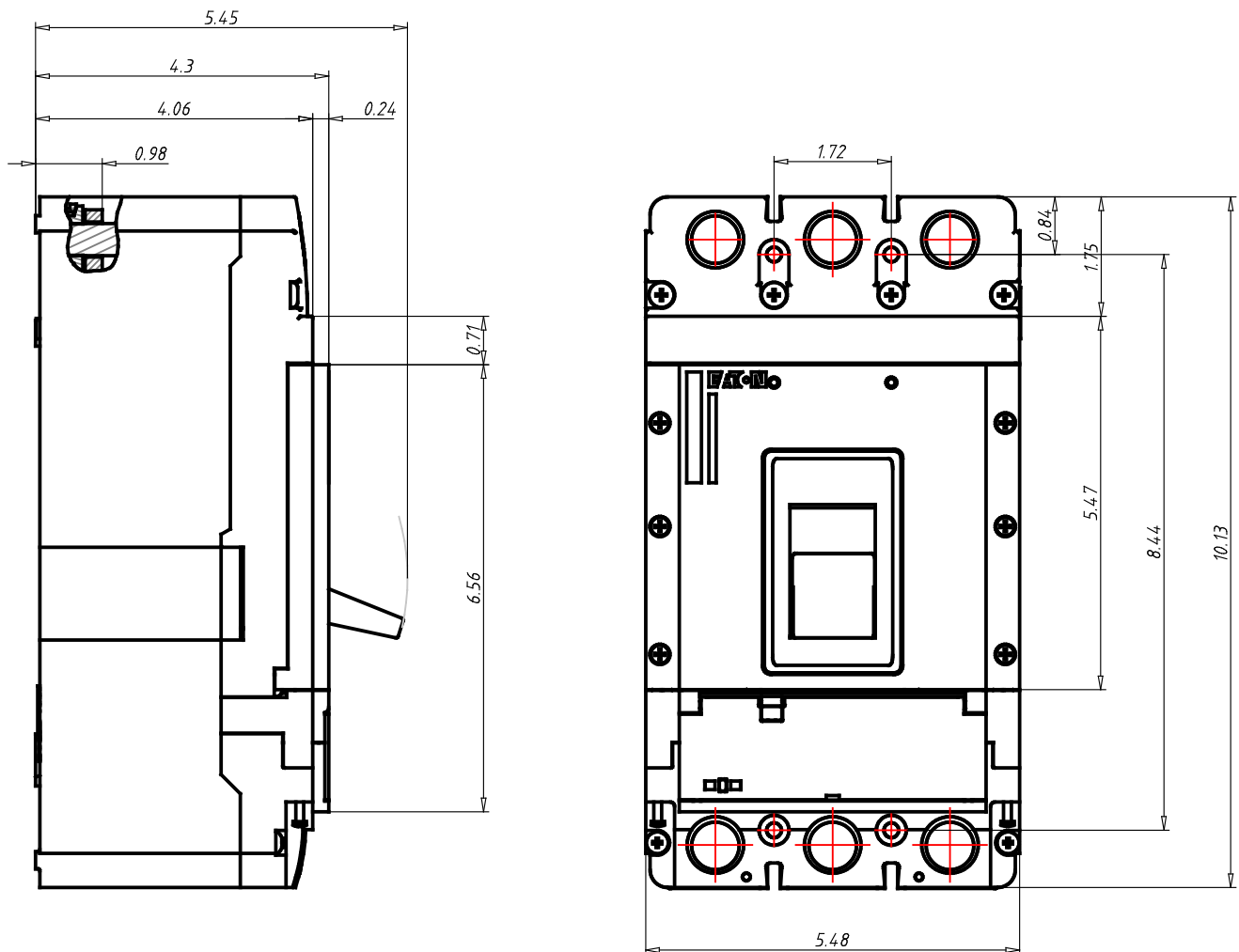

**Molded Case Circuit Breakers**  
**Power Defense™ UL Global Series**  
**Part Number: PDG33G0250B2NJNNNNNN**



Datasheet creation date: 02/12/2019

**General Technical Data**

Frame Rating (In)	250A
Reference Standard	UL489, CSA 22.2, IEC 60947-2 & GB
Number of poles	3
Neutral rating	-
Interruption Rating Designator	F / G / K / M / N / P
UL Interruption Rating to UL 489 (240Vac)	35 / 65 / 85 / 100 / 150 / 200kA
UL Interruption Rating to UL 489 (480Vac)	25 / 35 / 50 / 65(a) / 85 / 100kA
UL Interruption Rating to UL 489 (600Vac)	14 / 18 / 25 / 35 / 50 / 65kA
UL Interruption Rating to UL 489 (125/250Vdc)	
UL Current Limiting	N / N / N / Y / Y / Y
Rated breaking capacity to IEC 60947-2 (220-240 Vac Icu)	35 / 55 / 85 / 100 / 150 / 200kA
Rated breaking capacity to IEC 60947-2 (220-240 Vac Ics)	35 / 55 / 85 / 100 / 100 / 150kA
Rated breaking capacity to IEC 60947-2 (380-415 Vac Icu)	25 / 36 / 50 / 70 / 70 / 100kA
Rated breaking capacity to IEC 60947-2 (380-415 Vac Ics)	25 / 36 / 50 / 53 / 70 / 70kA
Rated breaking capacity to IEC 60947-2 (440 Vac Icu)	25 / 30 / 35 / 50 / 70 / 100kA
Rated breaking capacity to IEC 60947-2 (440 Vac Ics)	20 / 22.5 / 35 / 40 / 50 / 50kA
Rated breaking capacity to IEC 60947-2 (525 Vac Icu)	18 / 20 / 25 / 30 / 35 / 40kA
Rated breaking capacity to IEC 60947-2 (525 Vac Ics)	5 / 7.5 / 10 / 15 / 25 / 25kA
Rated breaking capacity to IEC 60947-2 (690 Vac Icu)	- / 8 / 10 / 15 / 20 / 20kA
Rated breaking capacity to IEC 60947-2 (690 Vac Ics)	- / 4 / 5 / 7.5 / 10 / 10kA
Rated breaking capacity to IEC 60947-2 (125V DC Icu)	
Rated breaking capacity to IEC 60947-2 (250V DC 2P in series Ics)	10 / 10 / 10 / 22 / 22 / 22kA
Frequency	50/60Hz
Trip Unit Type	PXR10
Continuous Current Range	90 - 250A
100% UL489 Rated	Yes
Instantaneous/Short Circuit Range	2 - 15 In
Magnetic/Instantaneous Override	4400A
Dimensions H x W x D (inches)	10.125 x 5.47 x 4.297
Pole to pole distance inches	1,719
Approx Weight lbs	16
RoHS Compliance	Yes
UL File Number	E7819
Ambient Temp Calibration	
Derating at 50C	
Derating at 60C	
Derating at 70C	

1. 480Vac corresponds to 277Vac for 1P
2. 600Vac corresponds to 347Vac for 1P

**Molded Case Circuit Breakers**  
**Power Defense™ UL Global Series**  
**Part Number: PDG33G0400B2NJNNNNNN**



Datasheet creation date: 02/12/2019

**PRODUCT VIEW** *(Use Mouse to Rotate and Zoom)*

Eaton's Power Defense™ molded case circuit breakers, a globally rated platform designed to help keep your power system safe with latest protection technology. Engineered for the future: IoT and Industry 4.0 features such as built-in communications, advanced energy metering, and algorithms that signal breaker maintenance; zone selective interlock technology that clears faults quickly and locally; ArcFlash reduction options that help protect your people, and not to mention Eaton's best-in-class support and service.

**Tech Data for Configured Product**

<b>Power Defense Catalog Number</b>	PDG33G0400B2NJNNNNNN
<b>Frame Size</b>	Frame 3
<b>Poles</b>	3 Pole
<b>Voltage</b>	480V AC
<b>Interruption or Breaking Capacity ( Icu/Ics)</b>	35kA
<b>Continuous Current Rating (In)</b>	400A
<b>Trip Unit Type</b>	PXR10
<b>Trip Unit Options 1</b>	LSI
<b>Trip Unit Options 2</b>	None
<b>Indicating Accessories</b>	None
<b>Indicating Accessories Terminal</b>	None
<b>Tripping Accessories</b>	None
<b>Tripping Accessory Terminal</b>	None
<b>Tripping Accessory Voltage</b>	None
<b>Line Type Description</b>	Option 1 - Standard Terminal
<b>Line Conductor Options</b>	(2) 3/0 - 250
<b>Line Terminal Type</b>	Aluminum
<b>Load Type Description</b>	Option 1 - Standard Terminal
<b>Load Conductor Options</b>	(2) 3/0 - 250
<b>Load Terminal Type</b>	Aluminum
<b>Special Options - Type of Modification</b>	None
<b>Details</b>	None
<b>Additional Description</b>	None

**Molded Case Circuit Breakers**  
**Power Defense™ UL Global Series**  
**Part Number: PDG33G0400B2NJNNNNNN**

**Technical drawings**

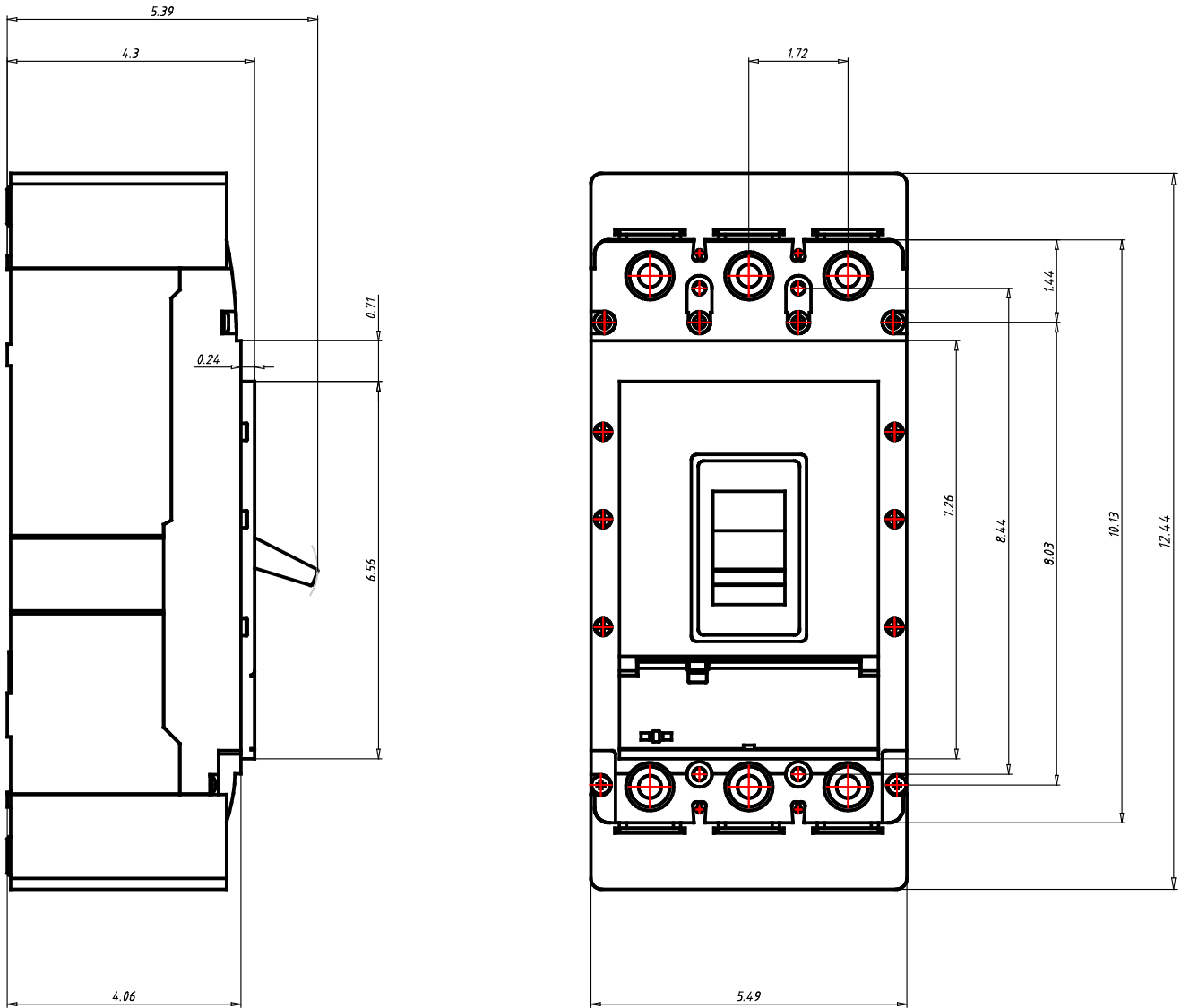

**Molded Case Circuit Breakers**  
**Power Defense™ UL Global Series**  
**Part Number: PDG33G0400B2NJNNNNNN**



Datasheet creation date: 02/12/2019

**General Technical Data**

Frame Rating (In)	400A
Reference Standard	UL489, CSA 22.2, IEC 60947-2 & GB
Number of poles	3
Neutral rating	-
Interruption Rating Designator	F / G / K / M / N / P
UL Interruption Rating to UL 489 (240Vac)	35 / 65 / 85 / 100 / 150 / 200kA
UL Interruption Rating to UL 489 (480Vac)	25 / 35 / 50 / 65(a) / 85 / 100kA
UL Interruption Rating to UL 489 (600Vac)	14 / 18 / 25 / 35 / 50 / 65kA
UL Interruption Rating to UL 489 (125/250Vdc)	
UL Current Limiting	N / N / N / Y / Y / Y
Rated breaking capacity to IEC 60947-2 (220-240 Vac Icu)	35 / 55 / 85 / 100 / 150 / 200kA
Rated breaking capacity to IEC 60947-2 (220-240 Vac Ics)	35 / 55 / 85 / 100 / 100 / 150kA
Rated breaking capacity to IEC 60947-2 (380-415 Vac Icu)	25 / 36 / 50 / 70 / 70 / 100kA
Rated breaking capacity to IEC 60947-2 (380-415 Vac Ics)	25 / 36 / 50 / 53 / 70 / 70kA
Rated breaking capacity to IEC 60947-2 (440 Vac Icu)	25 / 30 / 35 / 50 / 70 / 100kA
Rated breaking capacity to IEC 60947-2 (440 Vac Ics)	20 / 22.5 / 35 / 40 / 50 / 50kA
Rated breaking capacity to IEC 60947-2 (525 Vac Icu)	18 / 20 / 25 / 30 / 35 / 40kA
Rated breaking capacity to IEC 60947-2 (525 Vac Ics)	5 / 7.5 / 10 / 15 / 25 / 25kA
Rated breaking capacity to IEC 60947-2 (690 Vac Icu)	- / 8 / 10 / 15 / 20 / 20kA
Rated breaking capacity to IEC 60947-2 (690 Vac Ics)	- / 4 / 5 / 7.5 / 10 / 10kA
Rated breaking capacity to IEC 60947-2 (125V DC Icu)	
Rated breaking capacity to IEC 60947-2 (250V DC 2P in series Ics)	10 / 10 / 10 / 22 / 22 / 22kA
Frequency	50/60Hz
Trip Unit Type	PXR10
Continuous Current Range	160 - 400A
100% UL489 Rated	Yes
Instantaneous/Short Circuit Range	2 - 10 In
Magnetic/Instantaneous Override	4400A
Dimensions H x W x D (inches)	10.125 x 5.47 x 4.297
Pole to pole distance inches	1,719
Approx Weight lbs	16
RoHS Compliance	Yes
UL File Number	E7819
Ambient Temp Calibration	
Derating at 50C	
Derating at 60C	
Derating at 70C	

1. 480Vac corresponds to 277Vac for 1P
2. 600Vac corresponds to 347Vac for 1P

# GUEST® Genset Chargers



**G**uest chargers are proven performers in genset applications. For specific application information, or if you are developing a new product, be sure to consult with the Guest applications engineering team to ensure the correct charger is specified.

## Genset Chargers

MODEL	TOTAL AMPS	OUT-PUTS	AMPS PER OUTPUT	BATTERY SYSTEM	INPUT VOLTAGE	AC	DC	DIMENSIONS	WT. (LBS)	AGENCY LISTING
2602A-12	2	1	2	12V	100 - 130 50/60Hz	6' w/ Connect- Charge plug	4' w/ ring terminals	2.9" x 5.1" x 1.5"	2	UL
2602A-12-B (bulk)										
2605A-1-24RT-01 (bulk pack only) (1)	5	1	5	24V	100 - 130 50/60Hz	6' SJT 18-3 w/ Connect- Charge plug	6' SJT 18-3 w/ ring terminals	7.4" x 6.3" x 2.4"	4.5	UL
2608A-B-01 (bulk pack only) (1)	6	1	6	12V	100 - 130 50/60Hz	6' cable w/ molded plug rated -40 to 105C	4' w/ ring terminals rated -40 to 105C	3.5" x 6.4" x 2.3"	4	UL
2610A	10	2	5/5	12V+12V	100 - 130 50/60Hz	Studs	Studs	5.5" x 7.8" x 2.4"	5.6	-
2610A-B (bulk)										UL (bulk only)

(1) 2-stage charging



Individual agency listings as shown in product chart.



# Plastic Magna Seal Air Cleaners



- Internal or External Evacuator Valve
- High Strength Polymer
- Working Temp -40c to +80c (-40F to 176F)
- Design Compatibility with other Manufacturers
- Industry Standard elements
- Can be Mounted Vertical or Horizontal

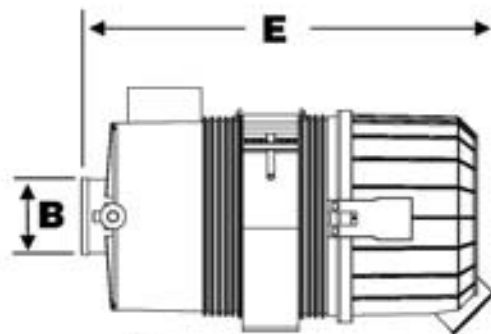
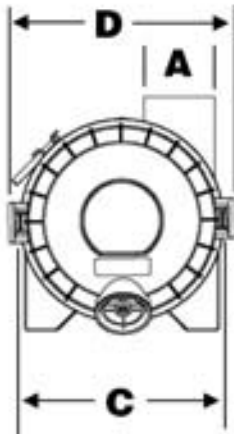

Type 1  
Straight Outlet

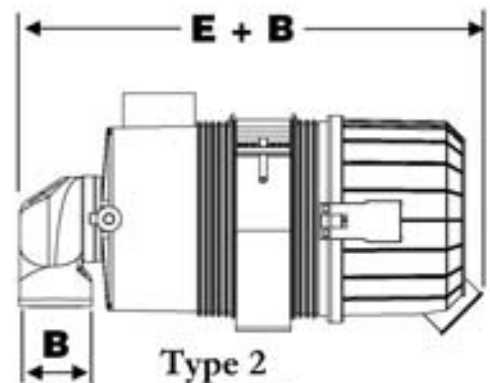

Type 2  
90° Outlet

Air Cleaner Assembly

Model Number	Part Number	Type	Initial Restriction						A		B		C		D		E	
			6" H2O		8" H2O		10" H2O		OD Inlet		OD Outlet							
			CFM	M3m	CFM	M3m	CFM	M3m	inch	mm	inch	mm	inch	mm	inch	mm	inch	mm
2s-FW-E1	68110	1	75	2.1	90	2.5	105	3.0	2.00	51	1.75	45	4.8	122	6.14	156	8.98	228
2s-FW-E2	68111	1	65	1.8	75	2.1	85	2.4	2.00	51	1.75	45	4.80	122	6.14	156	8.98	228
2s-FW-E1-90	68103	2	63	1.7	73	2.0	82	2.3	2.00	51	1.75	45	4.80	122	6.14	156	10.43	265
2s-FW-E2-90	68107	2	53	1.5	63	1.8	71	2.0	2.00	51	1.75	45	4.80	122	6.14	156	10.43	265
2-FW-E1	68120	1	100	2.8	115	3.3	130	3.7	2.00	51	2.00	51	5.75	146	7.09	180	13.39	340
2-FW-E2	68130	1	90	2.5	105	3.0	115	3.3	2.00	51	2.00	51	5.75	146	7.09	180	13.39	340
2-FW-E1-90	68116	2	88	2.4	102	2.9	113	3.2	2.00	51	2.00	51	5.75	146	7.09	180	14.96	380
2-FW-E2-90	68127	2	77	2.2	92	2.6	103	2.9	2.00	51	2.00	51	5.75	146	7.09	180	14.96	380
2.5-FW-E1	68132	1	150	4.2	175	5.0	195	5.5	2.50	63.5	2.50	63.5	6.89	175	8.15	207	14.13	359
2.5-FW-E2	68133	1	145	4.1	165	4.7	185	5.2	2.50	63.5	2.50	63.5	6.89	175	8.15	207	14.13	359
2.5-FW-E1-90	68131	2	134	3.8	156	4.4	175	5.0	2.50	63.5	2.50	63.5	6.89	175	8.15	207	16.22	412
2.5-FW-E2-90	68134	2	127	3.6	148	4.2	168	4.7	2.50	63.5	2.50	63.5	6.89	175	8.15	207	16.22	412
3-FW-E1	68140	1	160	4.5	190	5.4	210	5.9	3.00	76	3.00	76	7.24	184	8.58	218	14.57	370
3-FW-E2	68150	1	150	4.2	170	4.8	190	5.4	3.00	76	3.00	76	7.24	184	8.58	218	14.57	370
3-FW-E1-90	68140-2	2	154	4.4	181	5.1	196	5.6	3.00	76	3.00	76	7.24	184	8.58	218	17.80	452
3-FW-E2-90	68150-2	2	138	4.0	162	4.6	182	5.2	3.00	76	3.00	76	7.24	184	8.58	218	17.80	452
3.75-FW-E1	68160	1	250	7.1	290	8.4	325	9.2	3.75	95	3.50	89	8.35	212	9.72	247	15.63	397
3.75-FW-E2	68170	1	225	6.4	260	7.4	280	7.9	3.75	95	3.50	89	8.35	212	9.72	247	15.63	397
3.75-FW-E1-90	68157	2	212	6.0	250	7.1	277	7.8	3.75	95	3.50	89	8.35	212	9.72	247	18.5	470
3.75-FW-E2-90	68167	2	188	5.3	220	6.2	250	7.1	3.75	95	3.50	89	8.35	212	9.72	247	18.5	470
4.5-FW-E1	68175	1	375	10.6	425	12.0	475	13.5	4.50	114	4.00	102	10.60	268	11.9	302	19.13	486
4.5-FW-E2	68175-1	1	325	9.2	375	10.6	425	12.0	4.50	114	4.00	102	10.60	268	11.9	302	19.13	486
6-FW-E1	68178	1	600	17.0	685	19.4	770	21.8	6.00	152	5.00	127	12.20	309	13.54	344	22.00	560
6-FW-E2	68179	1	500	14.2	565	16.0	630	17.8	6.00	152	5.00	127	12.20	309	13.54	344	22.00	560
7-FW-E1	68182	1	800	22.7	910	25.8	1060	30.0	7.00	178	6.00	152	15.50	394	16.80	427	21.50	545
7-FW-E2	68185	1	710	20.1	830	23.5	960	27.2	7.00	178	6.00	152	15.50	394	16.80	427	21.50	545

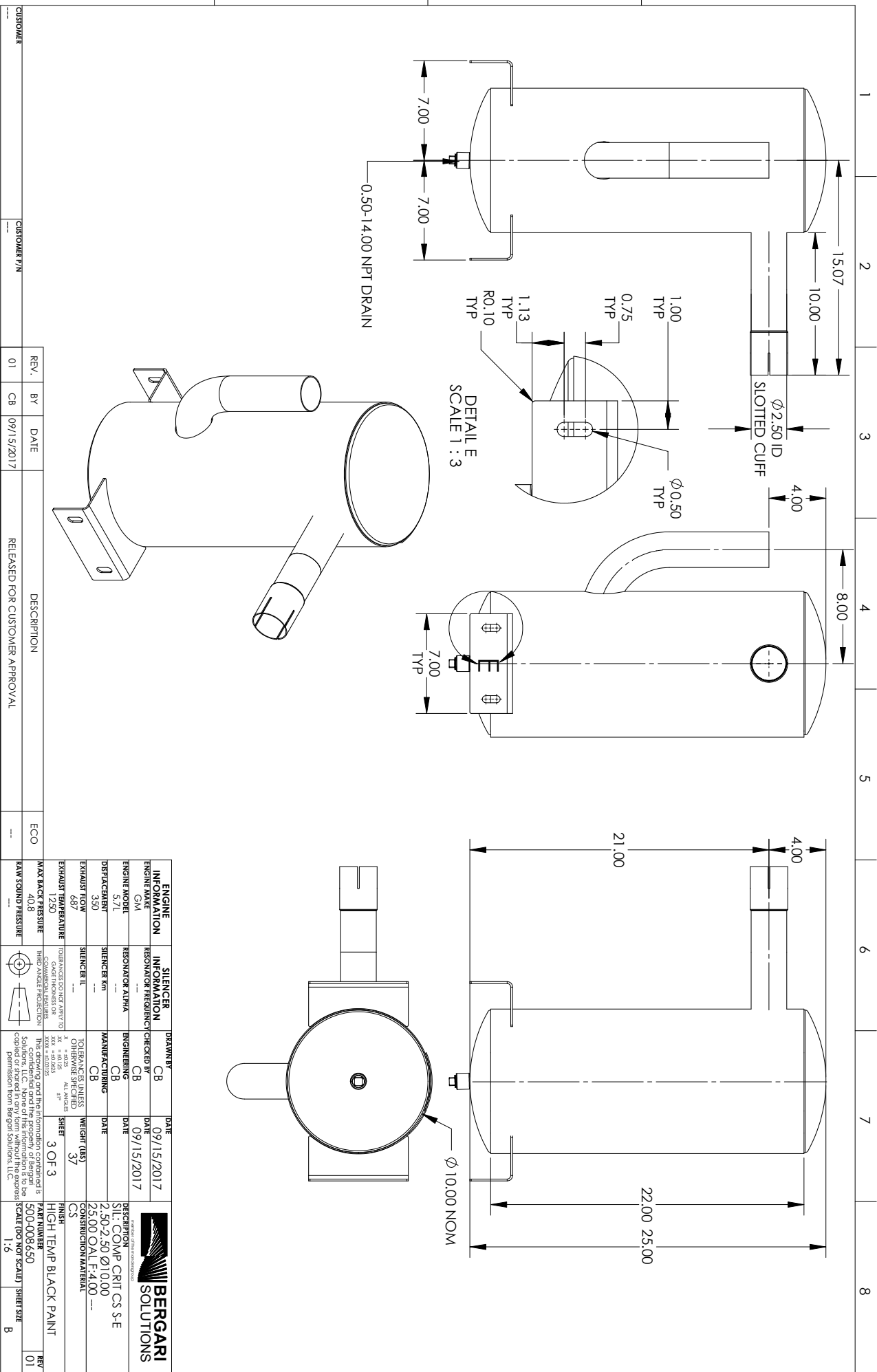

CUSTOMER	CUSTOMER P/N	REV.	BY	DATE	DESCRIPTION	ECO
---	---	01	CB	09/15/2017	RELEASED FOR CUSTOMER APPROVAL	---

<b>ENGINE INFORMATION</b>	<b>SILENCER INFORMATION</b>	<b>DRAWN BY</b>	<b>DATE</b>	<b>DESCRIPTION</b>
ENGINE MAKE: GM	RESONATOR FREQUENCY: ---	CB	09/15/2017	 BERGARI SOLUTIONS BERGARI SOLUTIONS, LLC 2500 OAL F-4.00 CONSTRUCTION MATERIAL CS
ENGINE MODEL: 5.7L	RESONATOR ALPHA: ---	CHECKED BY: CB	DATE: 09/15/2017	
DISPLACEMENT: 350	SILENCER Km: ---	ENGINEERING: CB	DATE: ---	
EXHAUST FLOW: 687	SILENCER TL: ---	MANUFACTURING: CB	DATE: ---	
EXHAUST TEMPERATURE: 1250	TOLERANCES TO THE RIGHT TO COMMERCIAL LEADERS	TOLERANCES UNLESS OTHERWISE SPECIFIED	WEIGHT (LBS): 37	
MAX BACK PRESSURE: 40.8	THIRD ANGLE PROJECTION	DATE: 09/15/2017	SHEET: 3 OF 3	FINISH: HIGH TEMP BLACK PAINT
RAW SOUND PRESSURE: ---	---	DATE: 09/15/2017	3 OF 3	PART NUMBER: 500-008650
				SCALE (DO NOT SCALE): 1:6
				SHEET SIZE: B
				REV: 01

This drawing and the information contained is the property of Bergari Solutions, LLC. None of this information is to be copied or stored in any form without the express permission from Bergari Solutions, LLC.

# OUTLINE DIMENSIONS FOR 41 THRU 62 KW OPEN GEN-SET

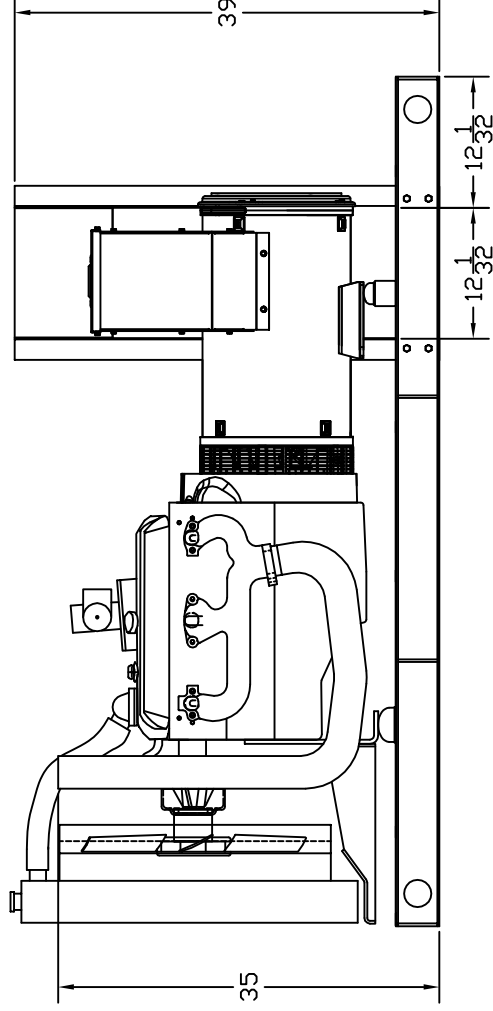
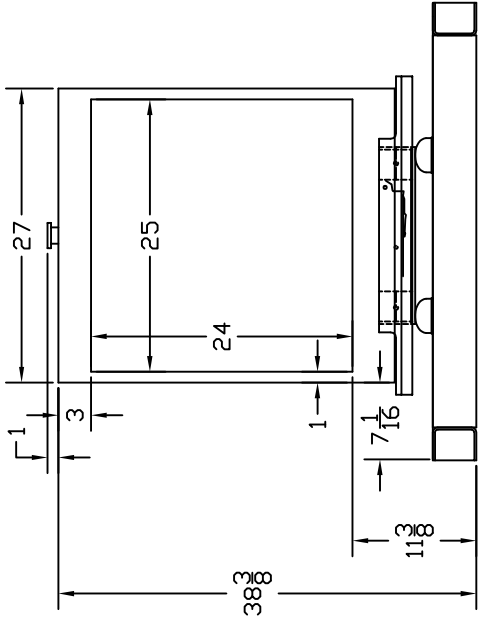
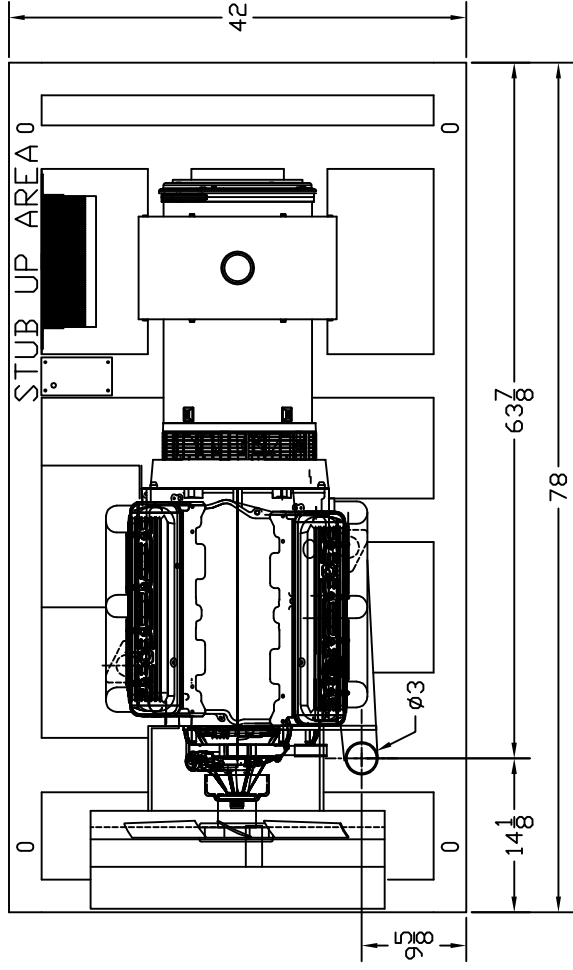

# OUTLINE DIMENSIONS FOR 41 THRU 62 KW LEVEL 2 ENCLOSURE (HINGED DOORS)

**TOP VIEW**

(GEN-SET HAS (4) DOORS, (2) SHOWN OPEN ARE TYPICAL FOR BOTH SIDES)

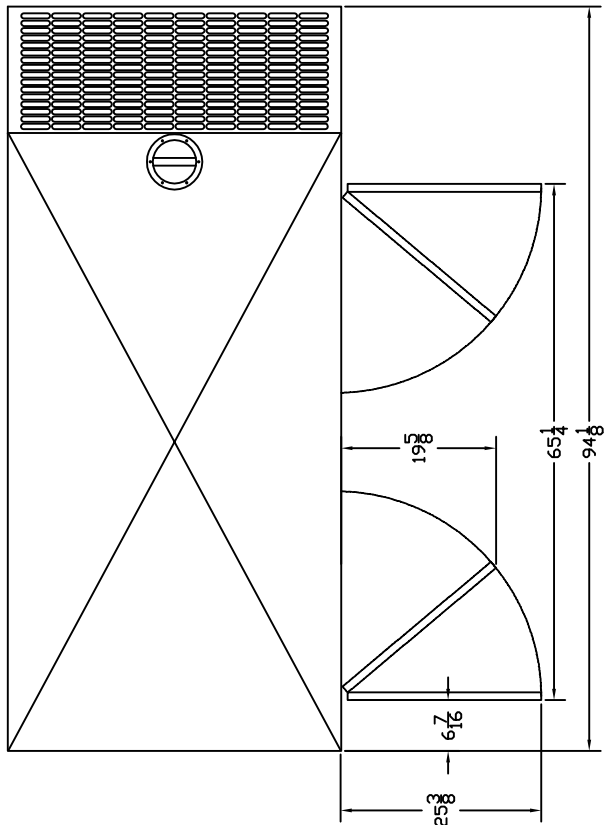

**FRAME VIEW**

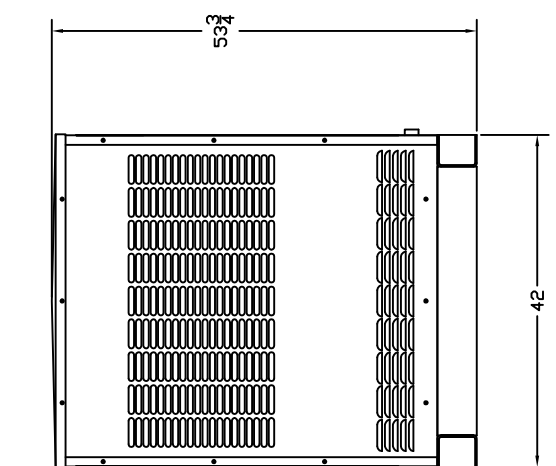
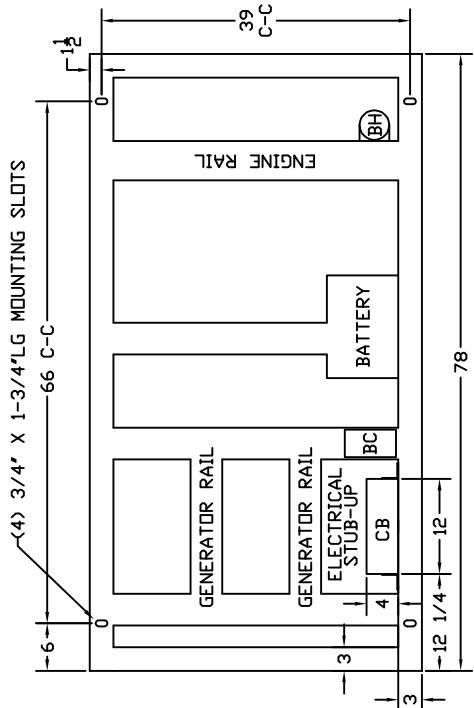

**GENERATOR END VIEW**

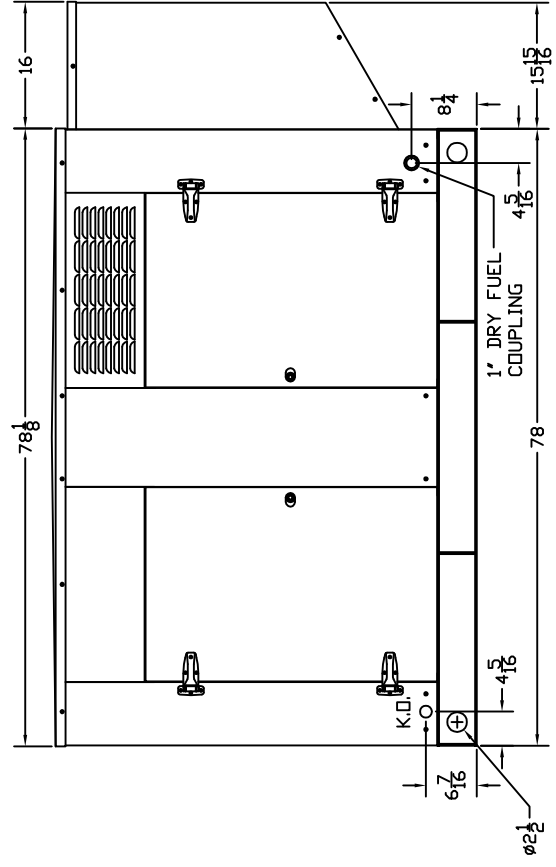

**SIDE VIEW**

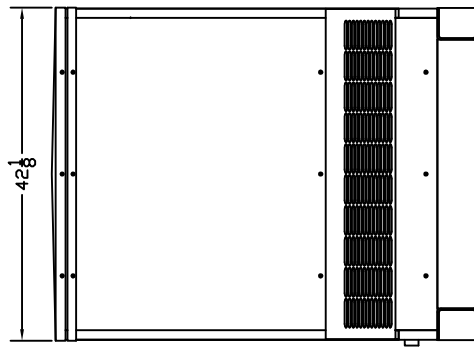

**RADIATOR END VIEW**